

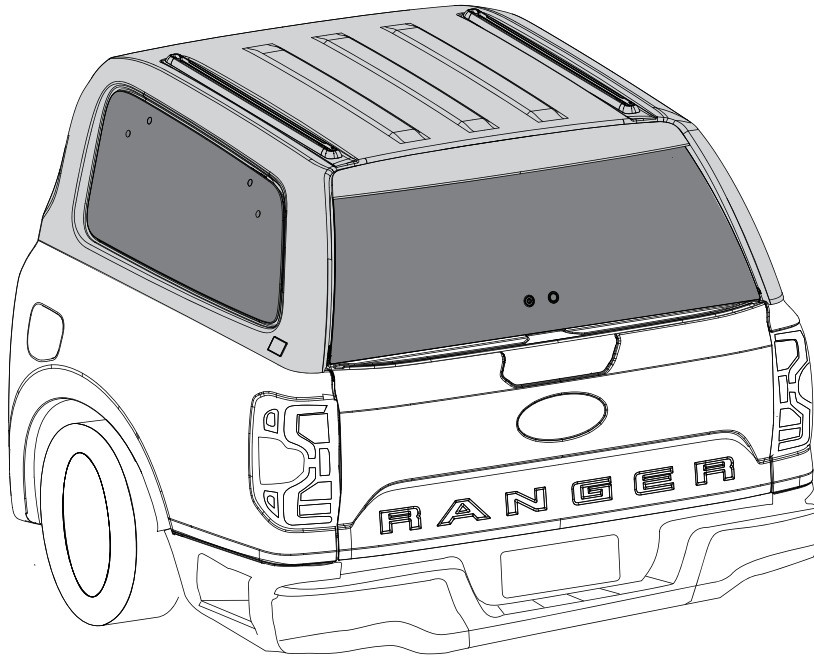

Gen III PREMIUM CANOPY FORD RANGER/RAPTOR MY22 Installation Instructions



Installation Time: Approx. 90 mins

Important



- Do not tighten any bolts, screws and nuts that are used in window frames, locks and glass assemblies. This may cause water leaks along window frames and glass windows to shatter.
- Read instructions carefully before installation.
- It is strongly recommended that installation is conducted by an authorized dealer.
- This product must be installed exactly as specified in these instructions. Failure to do so may result in improper fit and/or retention/failure of components.

PERSONAL PROTECTIVE EQUIPMENT:



Mask



Rubber Gloves



Goggles



Hearing Protection

Tools Required:

<ul style="list-style-type: none"> Drill Bits - Ø5.5mm, Ø9mm Drill Non-Permanent Marker Tape Measure Wire Cutters 	<ul style="list-style-type: none"> Torque Wrench 13mm Socket Silicone Hole Saw Ø30mm Debur Tool 	<ul style="list-style-type: none"> Wrench Center Punch Marking Tape Rivet Gun Torx Bit - T20, T40
----------------------------------------------------------------------------------------------------------------------------------------------------------------------	----------------------------------------------------------------------------------------------------------------------------------------------------	------------------------------------------------------------------------------------------------------------------------------------------------------

GLOSSARY



: Vehicle Part



: Sequence



: Part Provided



: Torque Setting



: Even Space



: Reuse



: Discard



: Complete for Both Sides



: Two People

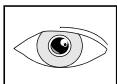

: Check



: Caution



: Clean

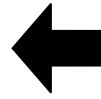

: Location

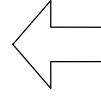

: Loosen

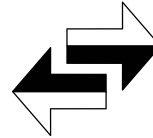

: Adjust



: Install & Remove



: Equal



: Disconnect



: Connect



: No Torque



: Lock



: Unlock

TUB BRACKET KIT:

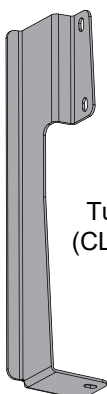

Tub Bracket LH
(CLIP4114PC-LH)
Qty - 1



Tub Bracket RH
(CLIP4114PC-RH)
Qty - 1



M8 Clutch Nut
(NUTS0250-1)
Qty - 4



M8 Washer
(WASH0171-1)
Qty - 8



Washer
(WASH0200)
Qty - 4

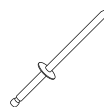

Rivet
(FAST0609)
Qty - 4

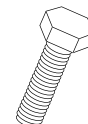



M8x40 Hex Screw
(SCRW0764)
Qty - 4





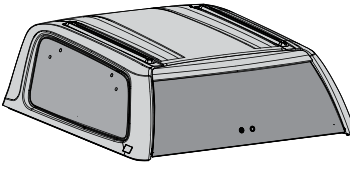
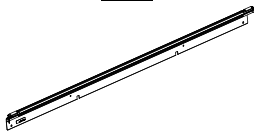
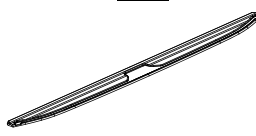
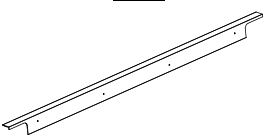
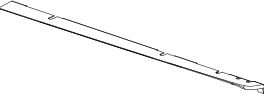
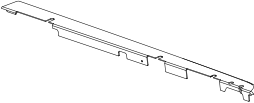

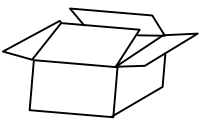



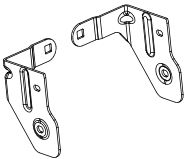
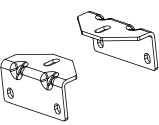
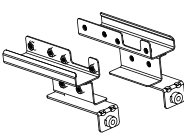
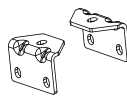

Panel Clip
Qty - 10

PARTS IN CANOPY KIT:

1  Canopy Qty - 1	2  Tailgate Rail (CNPY0101) Qty - 1	3  Tailgate Cap (S07415) Qty - 1	4  Tub Stop (ALUM0038-14PC) Qty - 1
5  Bedrail Cap LH (S07416-LH) Qty - 1	6  Berail Cap RH (S07416-RH) Qty - 1	 Keys Qty - 2	 Fitting Kit (KIT) Qty - 1

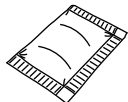

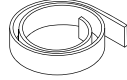
PARTS IN FITTING KIT:

7  Reinforcement Bracket (CLIP4092PC) Qty - 2	8  Large Side Brackets (CLIP4093PC) Qty - 4	9  Rear Support Bracket (CLIP4095PC) Qty - 2	10  Small Side Bracket (CLIP4091-PC) Qty - 2	11  Fir Tree Clip (FAST0635) Qty - 2	12  M8 Washer (WASH0171-1) Qty - 22	13  Rivet (FAST0609) Qty - 6	14  M8 Clutch Nut (NUTS0250-1) Qty - 14
15  M8x26 Screw (SCRW0949) Qty - 12	16  M8x40 Screw (SCRW0764) Qty - 8	17  Primer (MISC1365) Qty - 3	18  Alcohol Wipe (MISC0052) Qty - 2	19  Rust Inhibitor (MISC2778) Qty - 1	20  Anti-abrasion Tape (TAPE0342) Qty - 11	21  Foam Tape (TAPE0687) Qty - 1	

PARTS IN WIRING KIT:

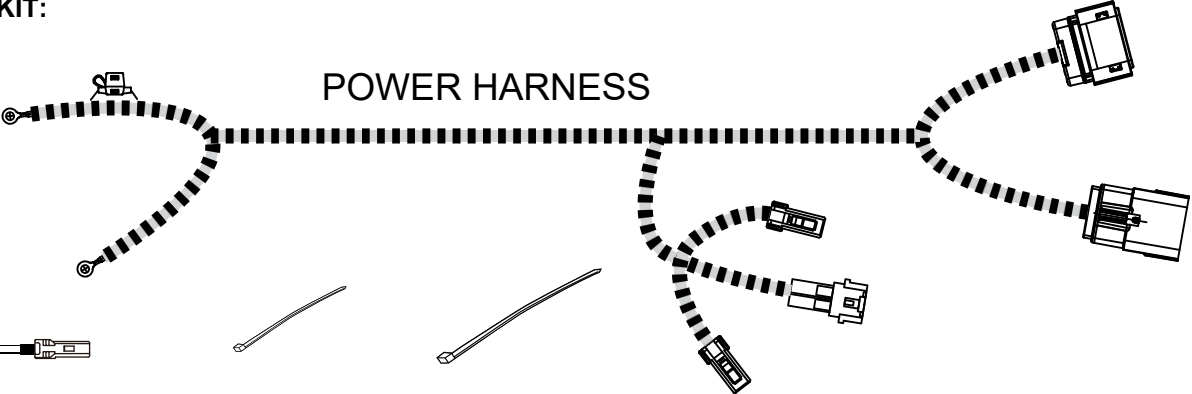
POWER HARNESS

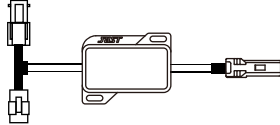

 T-PATCH (LOOM0235)	 Cable Tie (Short) (FAST0254) Qty - 35	 Cable Tie (Long) (CONS1590) Qty - 20
--------------------------------------------------------------------------------------------------------------	------------------------------------------------------------------------------------------------------------------------------------	-----------------------------------------------------------------------------------------------------------------------------------

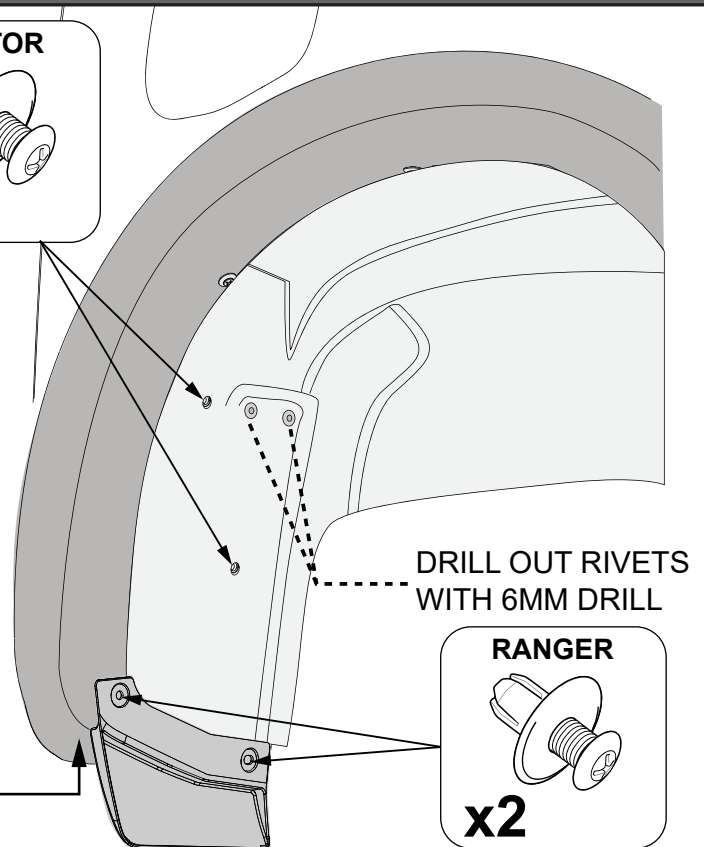
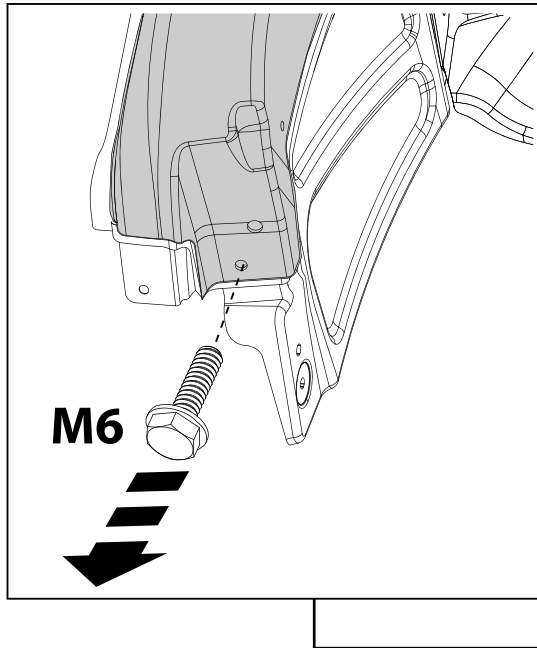
TUB BRACKET SECTION**FRONT
LHS SHOWN**

STEP 1 Remove 2x scrivets and 1x M6 screw as shown. Retain the scrivets, screw and mudflap for reattachment.
Note: Remove indicated scrivets for specified vehicle variants.

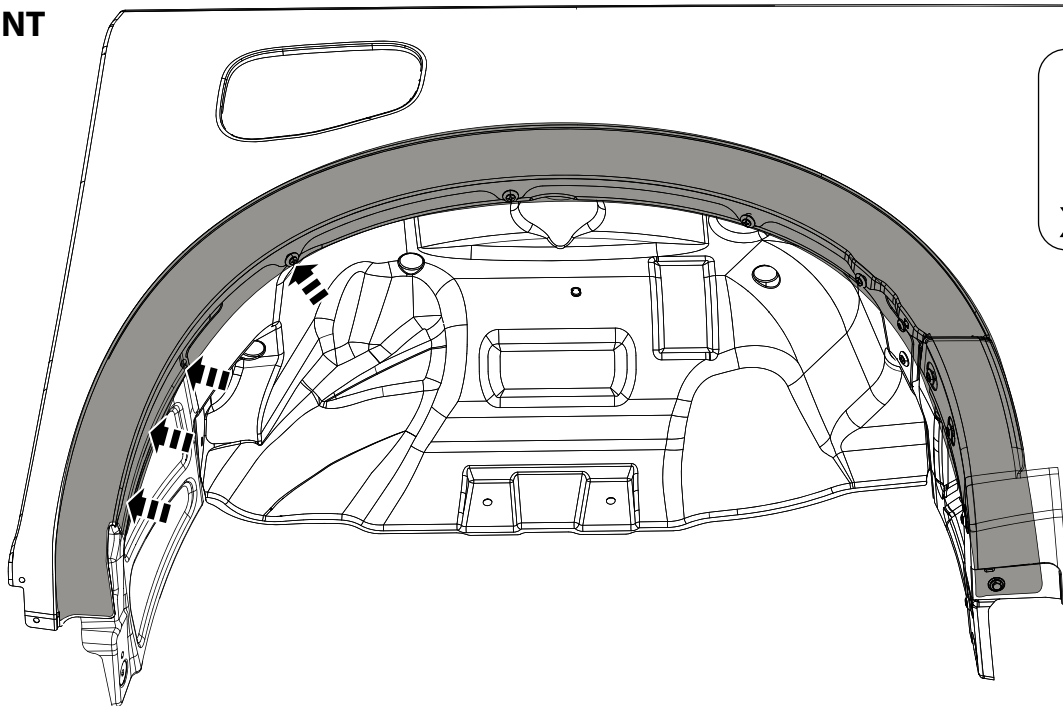
FRONT

STEP 2 Remove and retain 4x scrivets holding the front part of the wheel arch liner as shown.

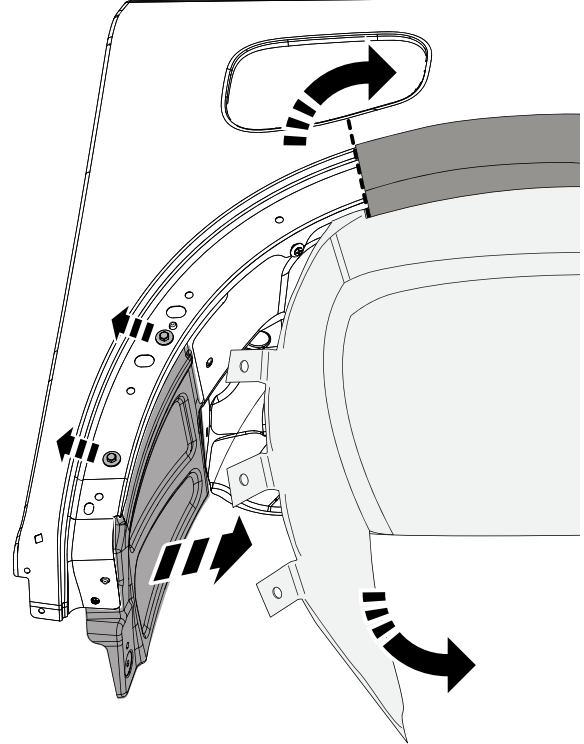
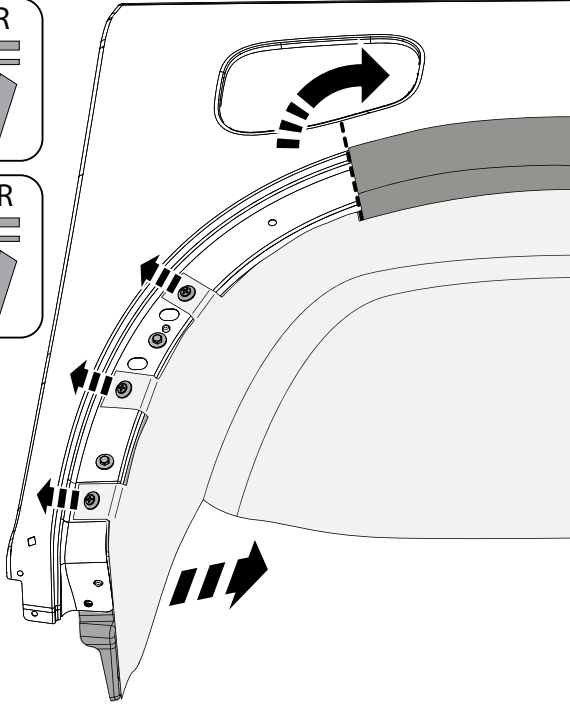
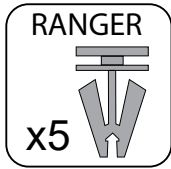
**STEP****3**

Lift the fender flare from the panel only half way to expose the 3x scrivets and 2x hex screws as shown. Remove the scrivets and pull forward the fabric liner. Remove the 2x hex screws and remove the mud guard. The fender flare clips may get damaged in the process if not careful. Lift the inner wheel arch splash guard to gain access to the tub cavity. Note: Information involving fabric liner is Raptor specific. Raptor will require only the first factory plug to be removed from the fender panel.

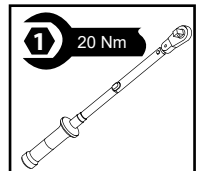
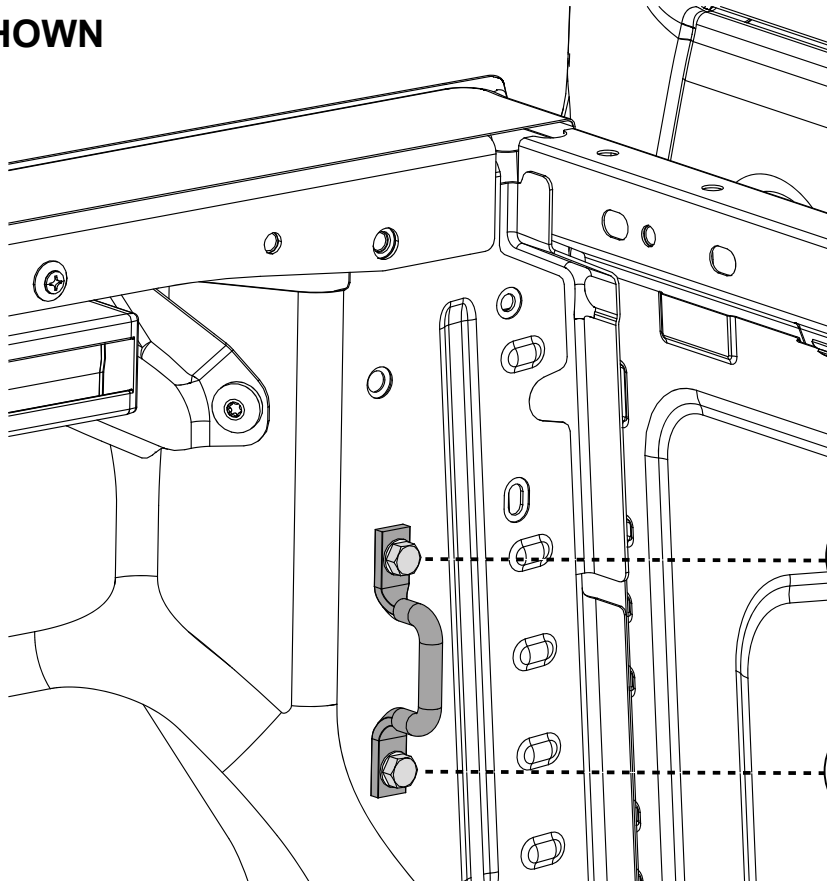
LHS SHOWN**STEP****4**

Replace 2x screws holding the utility hook with 2x M8 screws and washers as shown.

LHS SHOWN

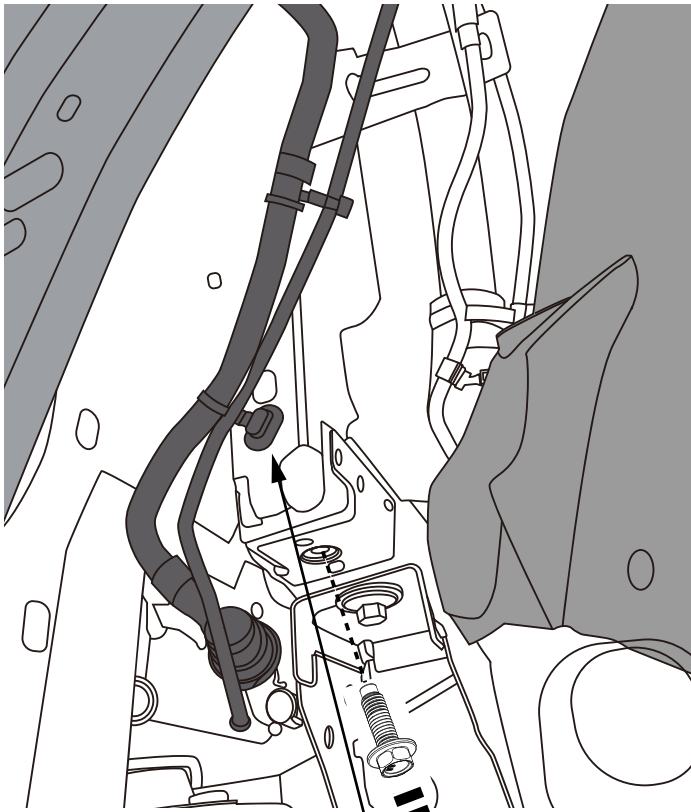

LIFT THE CLIP FROM THE CHASSIS

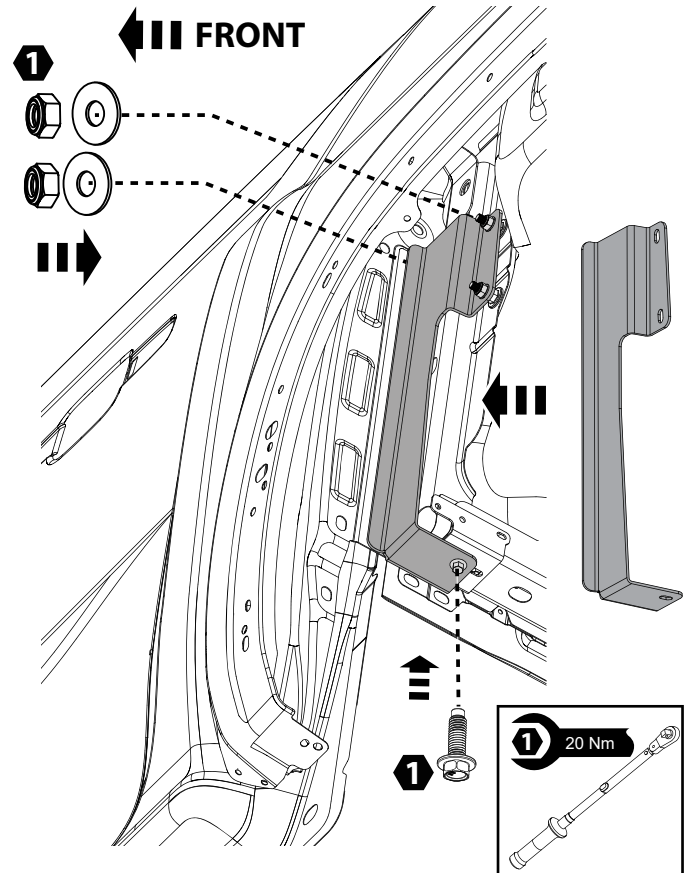

STEP

5

Unclip the fuel breather pipe by lifting up the plastic clip and remove screw as shown above. Push the pipe aside to allow the bracket fitment. Fit the tub bracket inside the tub cavity behind the rear fender. Place the 2x top holes over the 2x M8 screws from the utility hook and secure with 2x nuts and 2x washers. Secure the bottom part with the retained M8 screw. Torque to 20Nm.

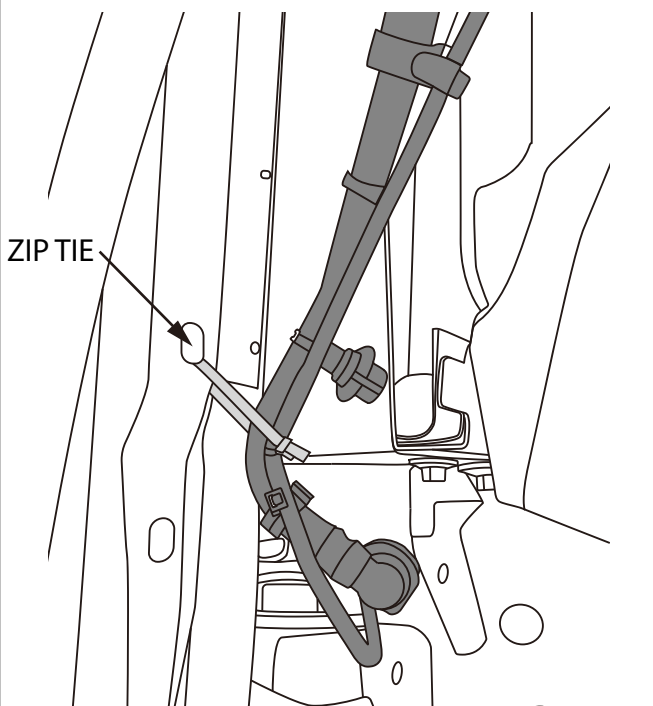

ZIP TIE

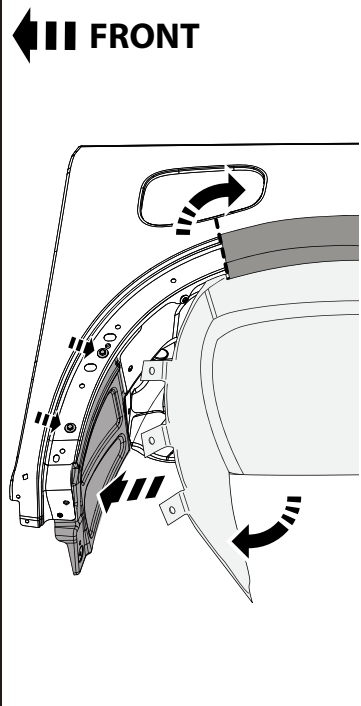

FRONT

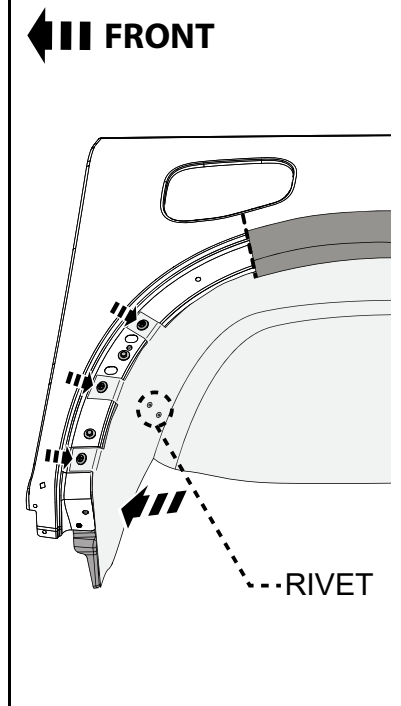

FRONT

RIVET

STEP

6

Once the bracket is fixed, secure the fuel breather pipe to the inner fender using 1x zip tie as shown. Refit and secure the mud splash guards in place using 2x hex screws previously removed. Resecure the fabric lining with 3x scrivets previously removed. Secure the guard with 2x rivets and flat washers as shown. Note: Information involving fabric liner is Raptor specific.

← || FRONT

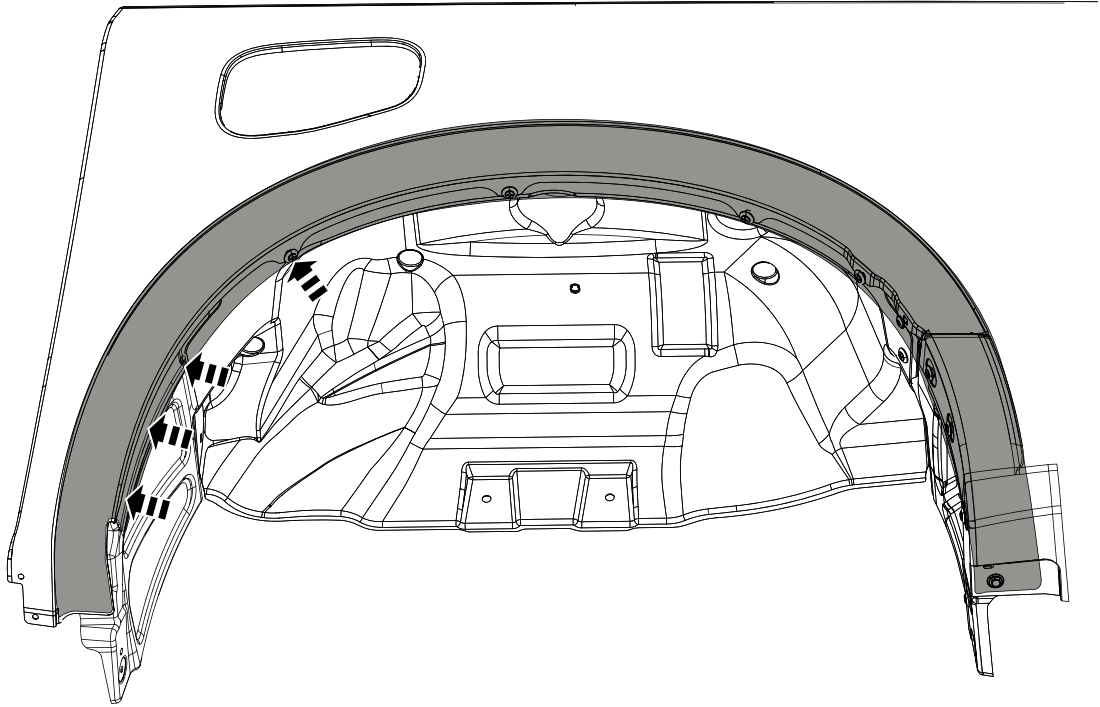

STEP

7

Secure the fender flare with 4x retained scrivets.

← || FRONT

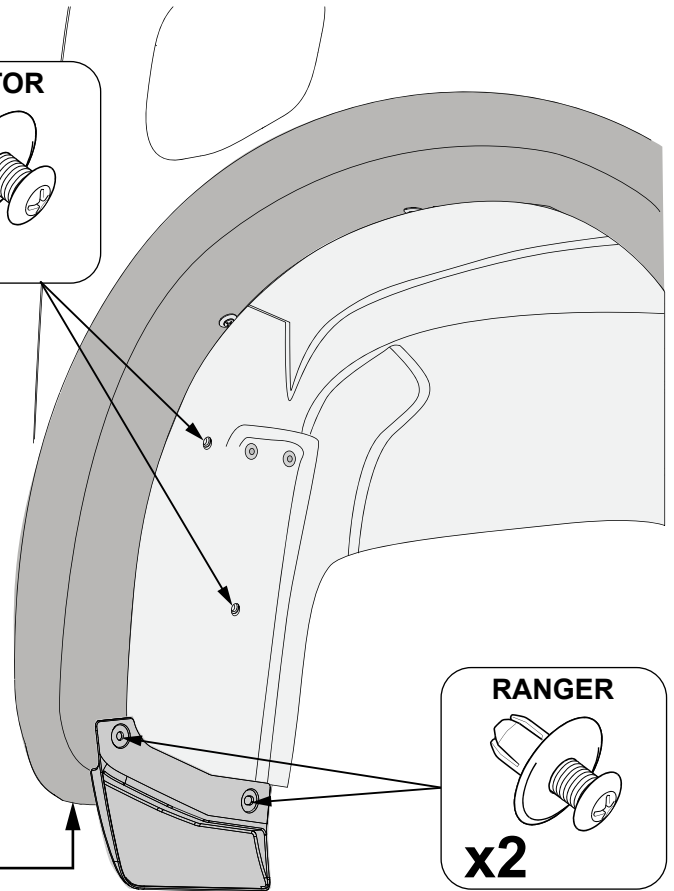
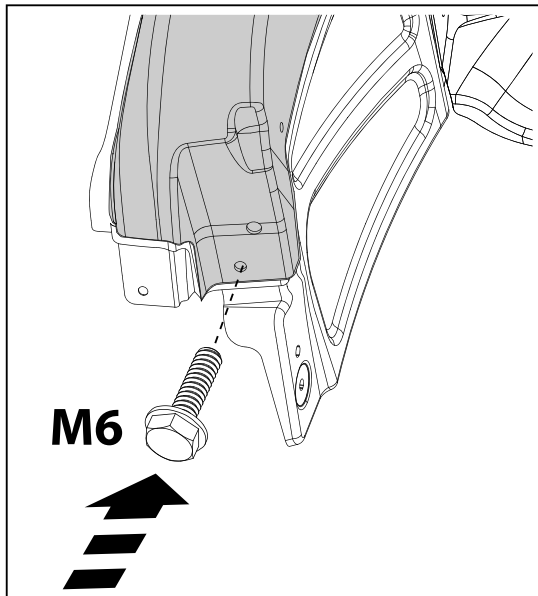

STEP

8

Raptor: Reinstall 2x scrivets as shown.
Ranger: Reinstall mudflap using 2x scrivets.
Reinstall the retained M6 screw as shown.

ELECTRICAL SECTION

POWER HARNESS

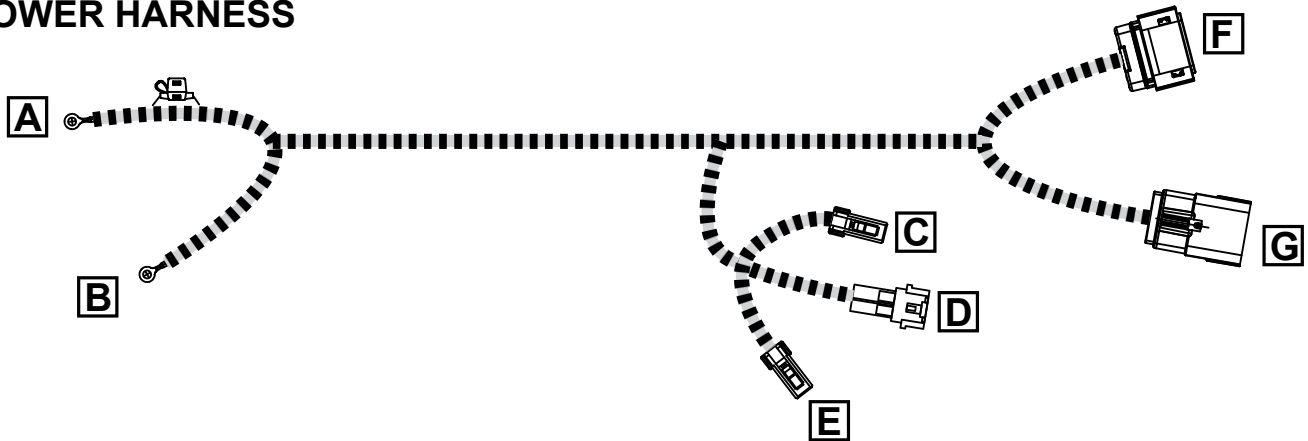

**IMPORTANT: DISCONNECT CAR BATTERY NEGATIVE TERMINAL.
FIT THE SUPPLIED FUSES AT THE END OF INSTALLATION.**



STEP 1

STEP 2

STEP 3

STEP 4

STEP 5,6

STEP 7

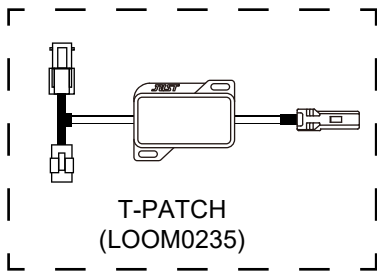
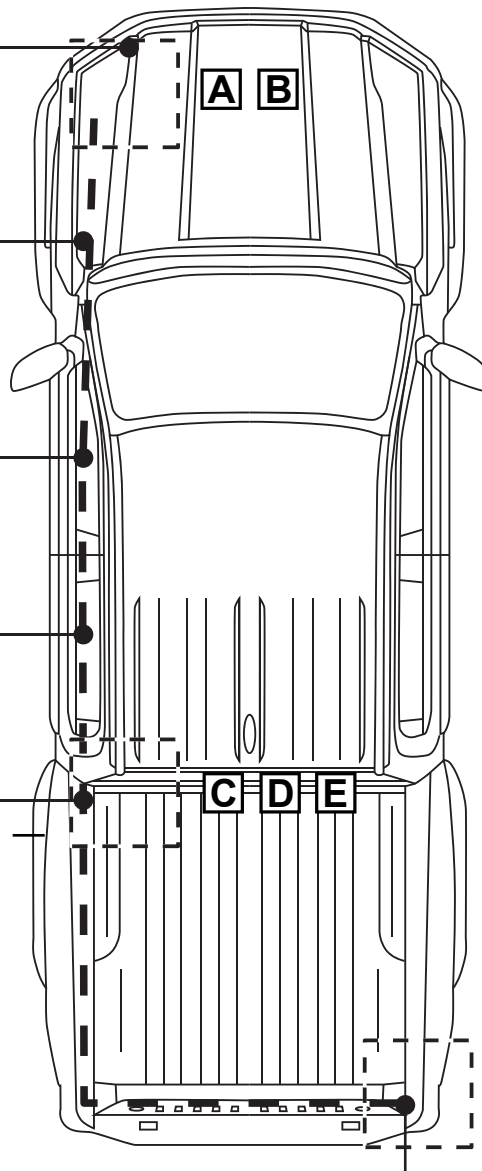

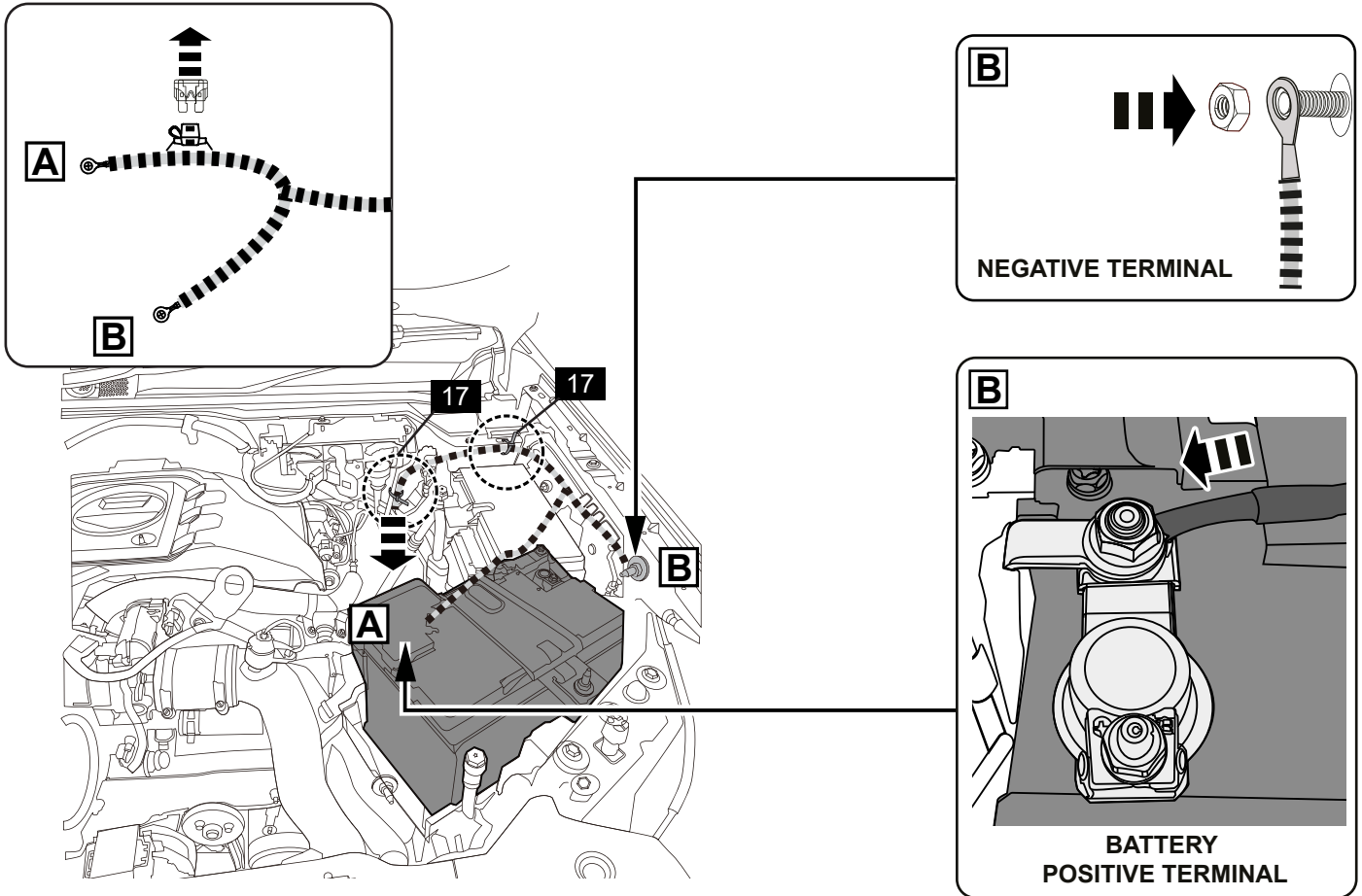
**STEP****1****IMPORTANT:** Make sure the fuse is not fitted before making connection.

Connect the vehicle harness branch (B) to vehicle body negative ground. Connect the vehicle harness branch (A) to the positive terminal of the battery. Once it is positioned, secure in place using 2x Cable Ties (17) as shown.

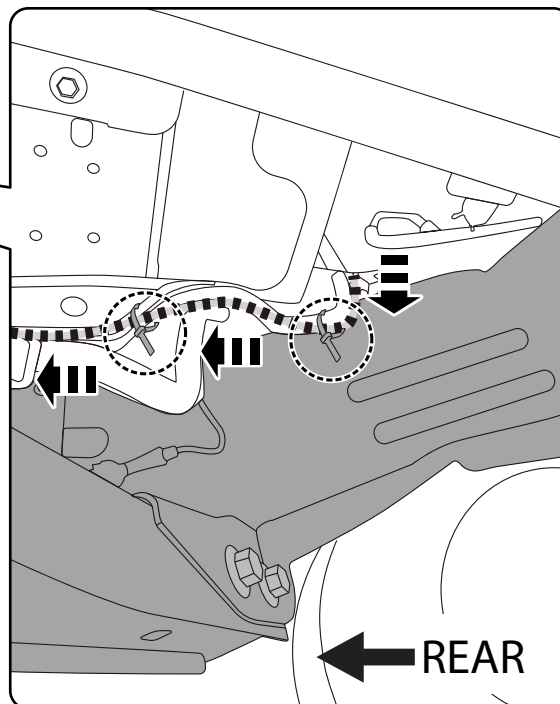
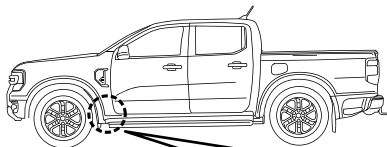
**STEP****2**

Pull the Power Harness from engine bay down to the floor behind the front left wheel. Direct it towards the rear of the vehicle. Secure the Power Harness to the vehicle loom in the 2x areas shown using short Cable Ties.

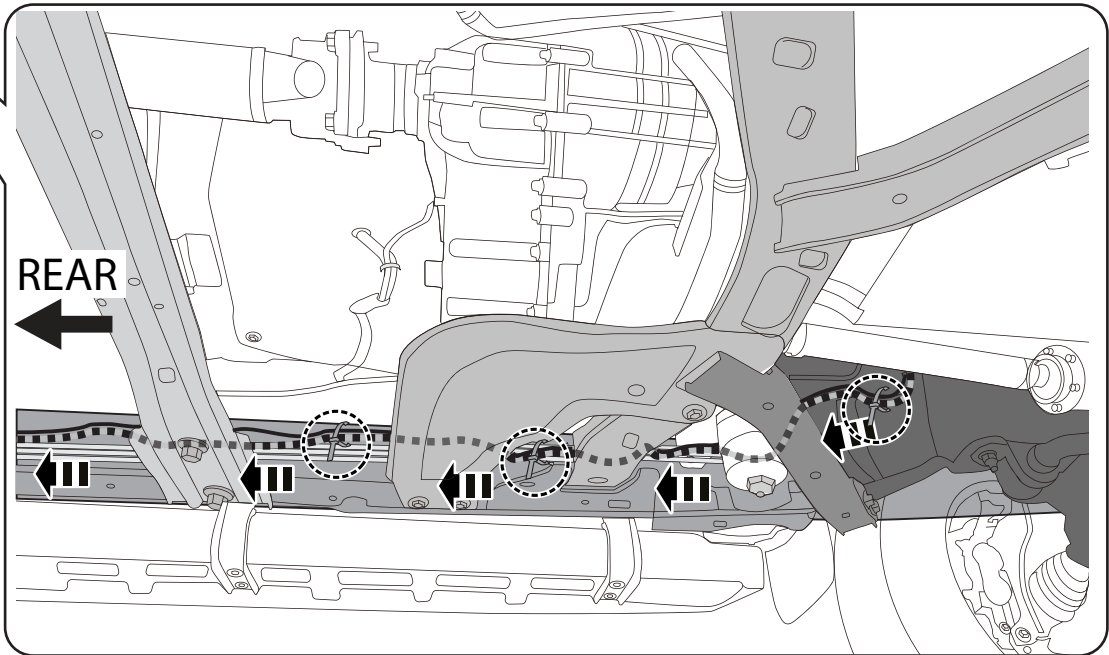
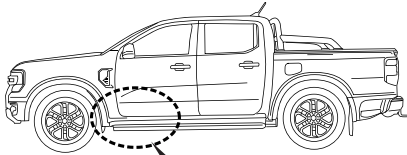
**STEP****3**

Along the **chassis inner side**, secure the Power Harness to the vehicle harness as shown using Cable Ties.

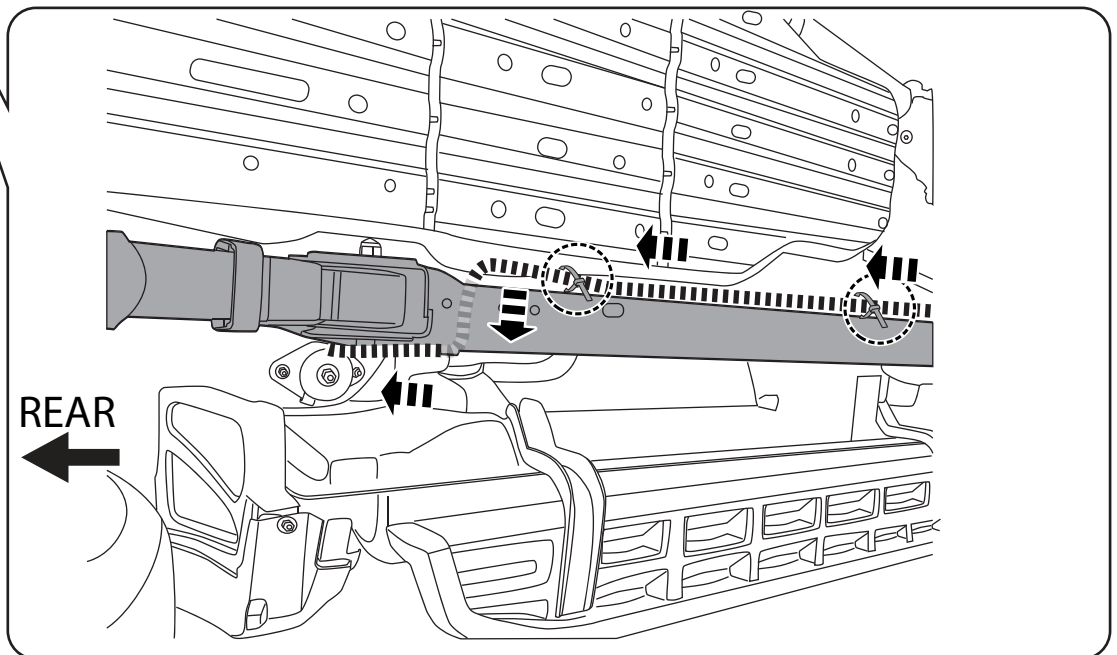
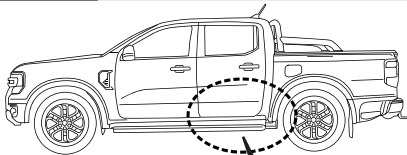
**STEP****4**

Continue running the Power Harness along the **chassis inner side**. Feed the Harness to the **outside of the chassis** at the rear wheel arch as shown. Secure with 2x Cable Ties as shown.

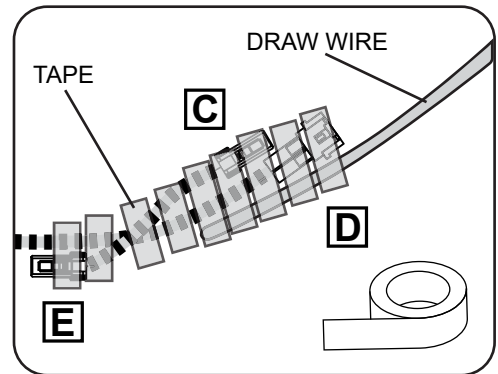
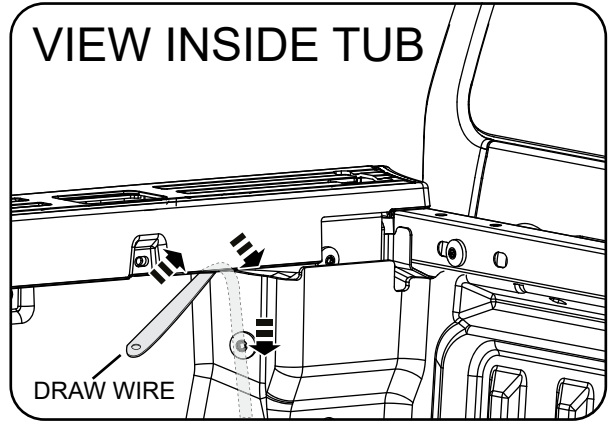
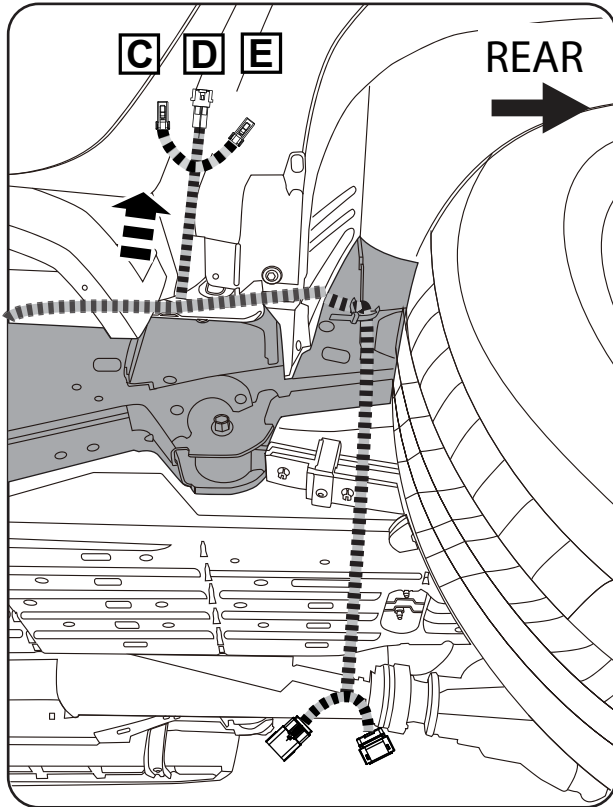

STEP 5 Push a draw wire down through the opening in the front LHS of the tub. Under the tub, wrap the Power Harness connectors **C, D, E** to the draw wire as shown. Pull up into the tub until approximately 300mm protrudes. Remove tape and draw wire from the harness.

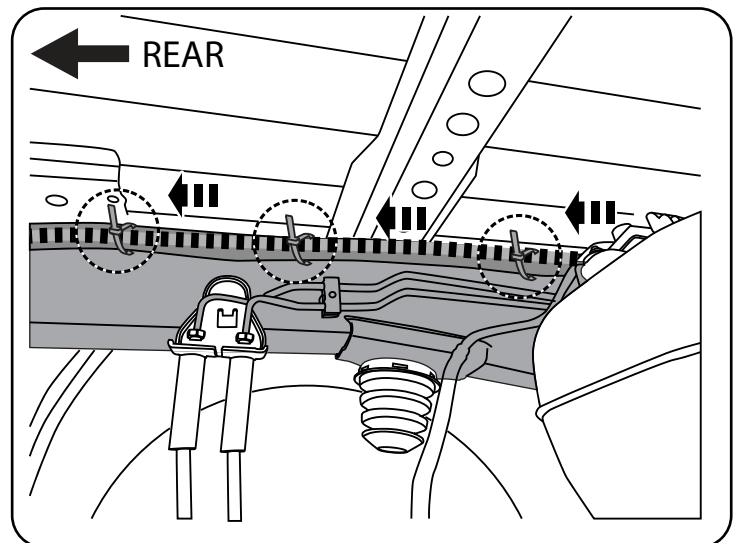
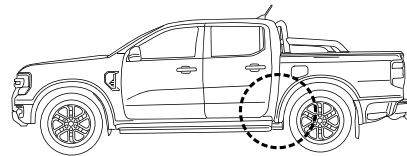
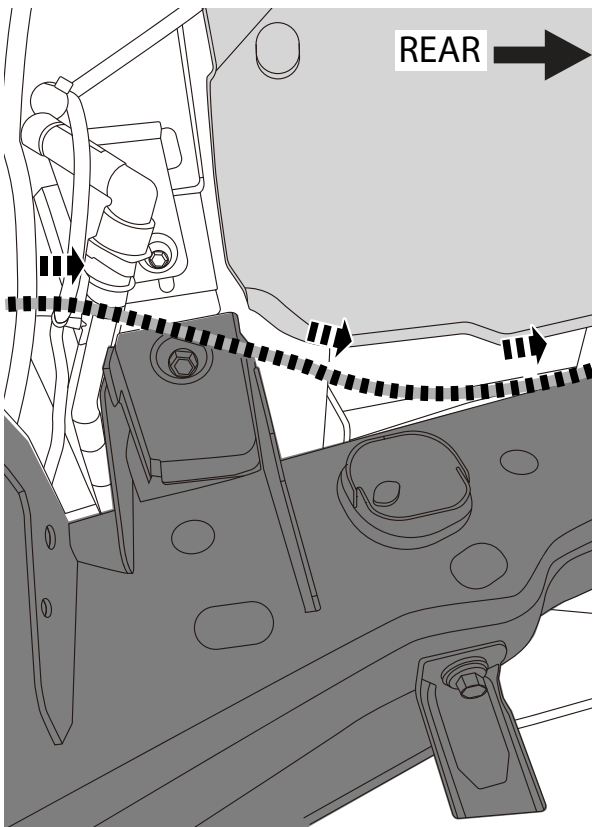

STEP 6 Push the remaining harness to the **inner chassis rail** and continue running it towards the rear of the vehicle. Secure with 3x Cable Ties.

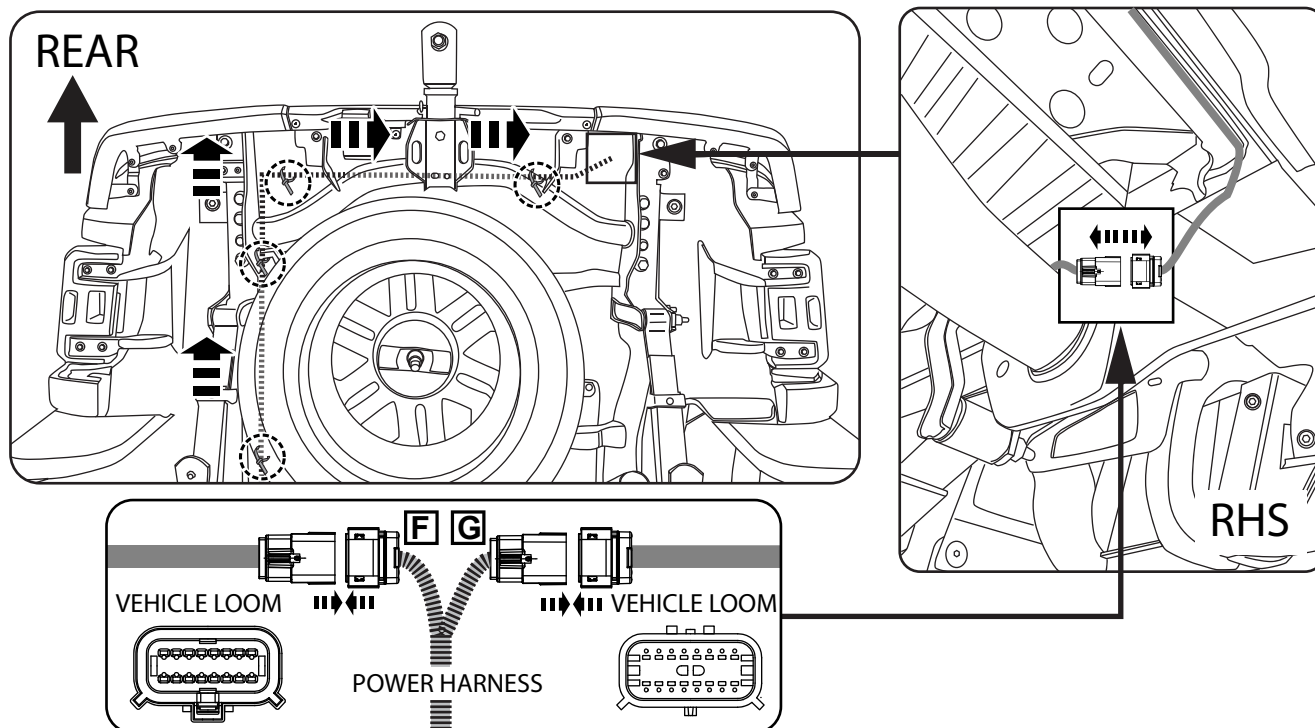
**STEP****7**

Running the Power Harness along the **inner chassis side** till reaching a loom connection. Run the Power Harness along the tail end of the vehicle till reaching the loom connection on the other side of the vehicle. Secure the Power Harness to the vehicle tub in 4x locations shown using short zip ties. Disconnect the 16 pin vehicle loom connectors and patch using **F** and **G** Power Harness connectors.

END OF ELECTRICAL SECTION

TUB PREP

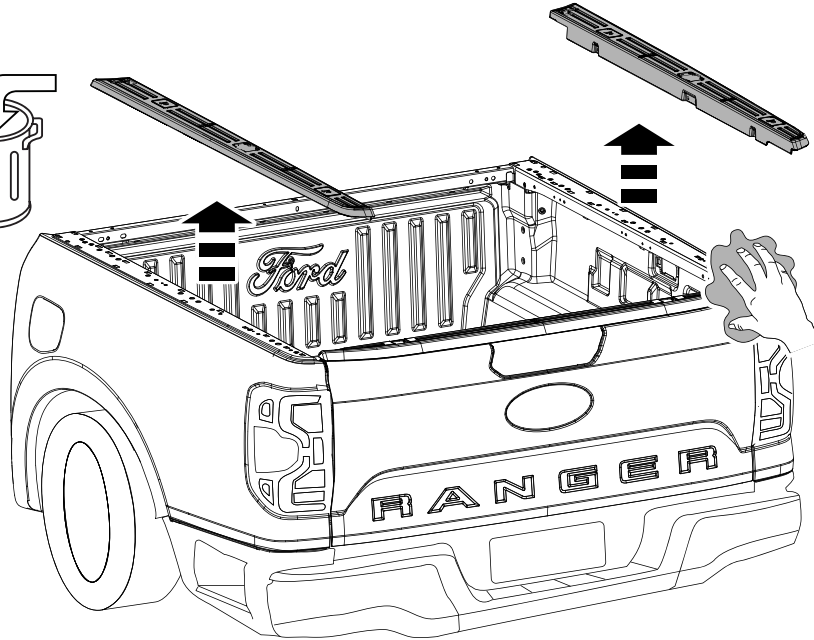
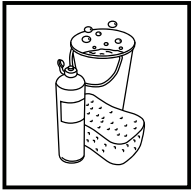

STEP
1

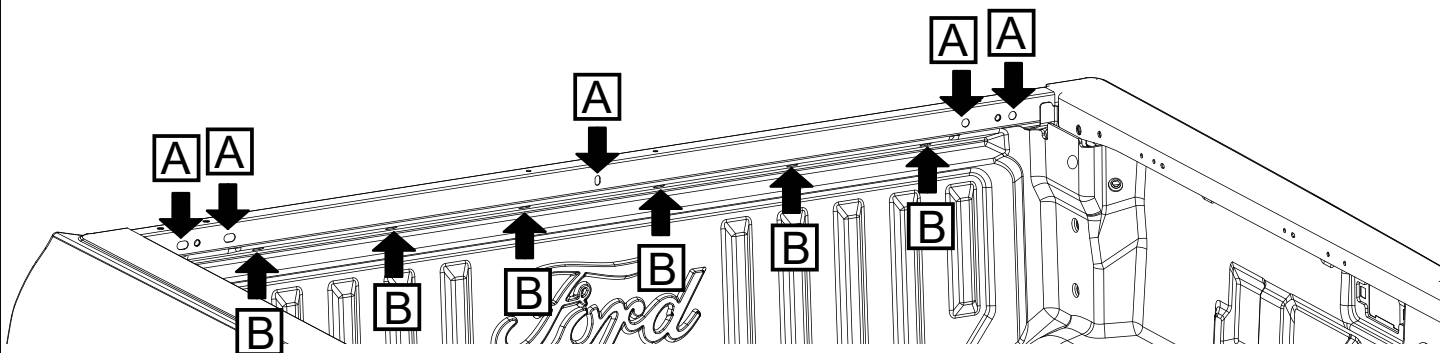
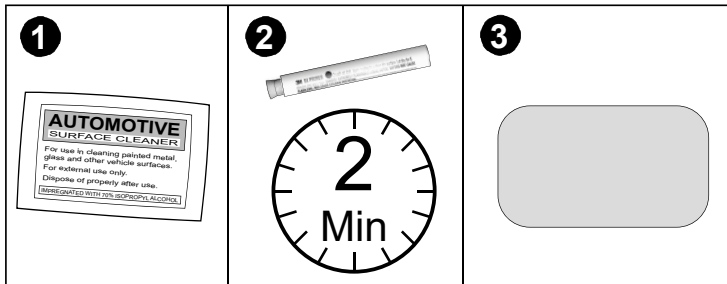
Remove the tub side caps as per Ford workshop manual and discard. Clean the tub of all debris.

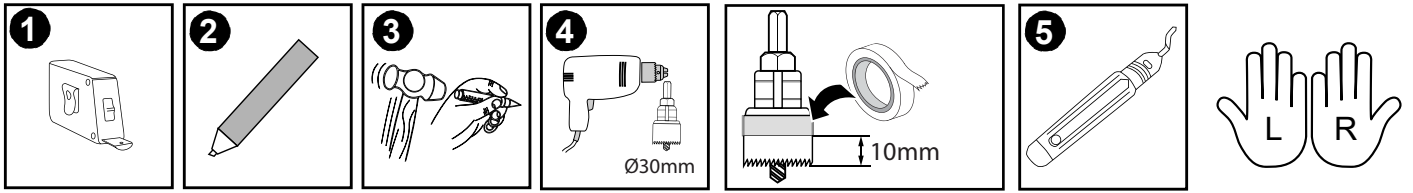

STEP
2

On the front part of the tub rail, cover the large slotted holes (A) with clear tape (20).
 NOTE: If tubliner not fitted, cover the six holes (B) located below the front top of the tub rail as show.

EGR FORD RANGER/RAPTOR GEN3 PREMIUM CANOPY

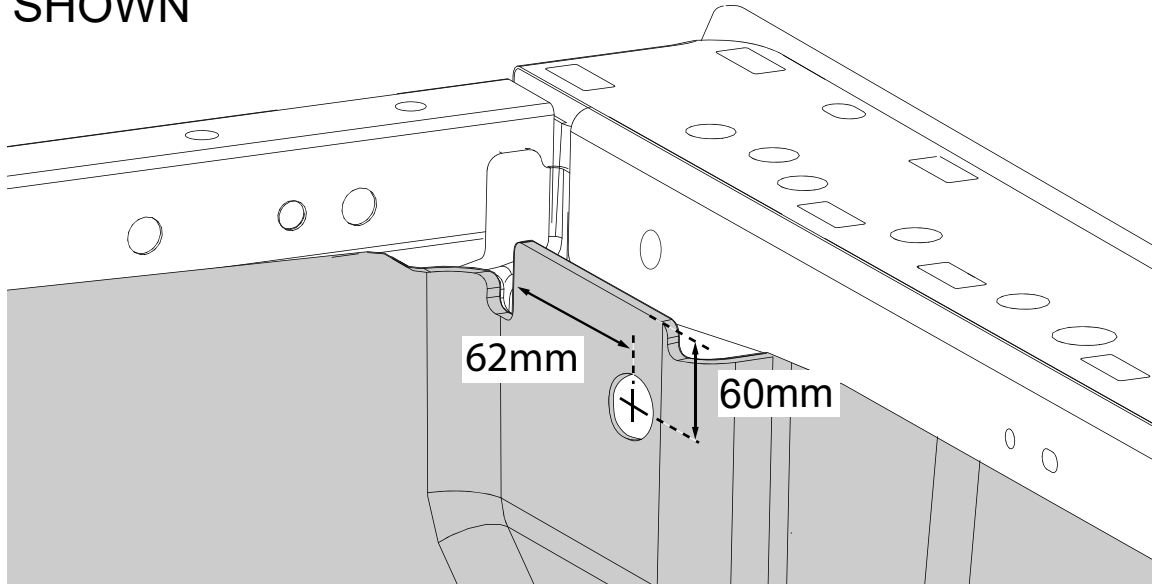

RHS SHOWN



STEP

3

Drill Ø30mm hole in the **tubliner ONLY** on the RHS of the tub as indicated. Repeat for LHS.
Note: Do not remove tubliner.

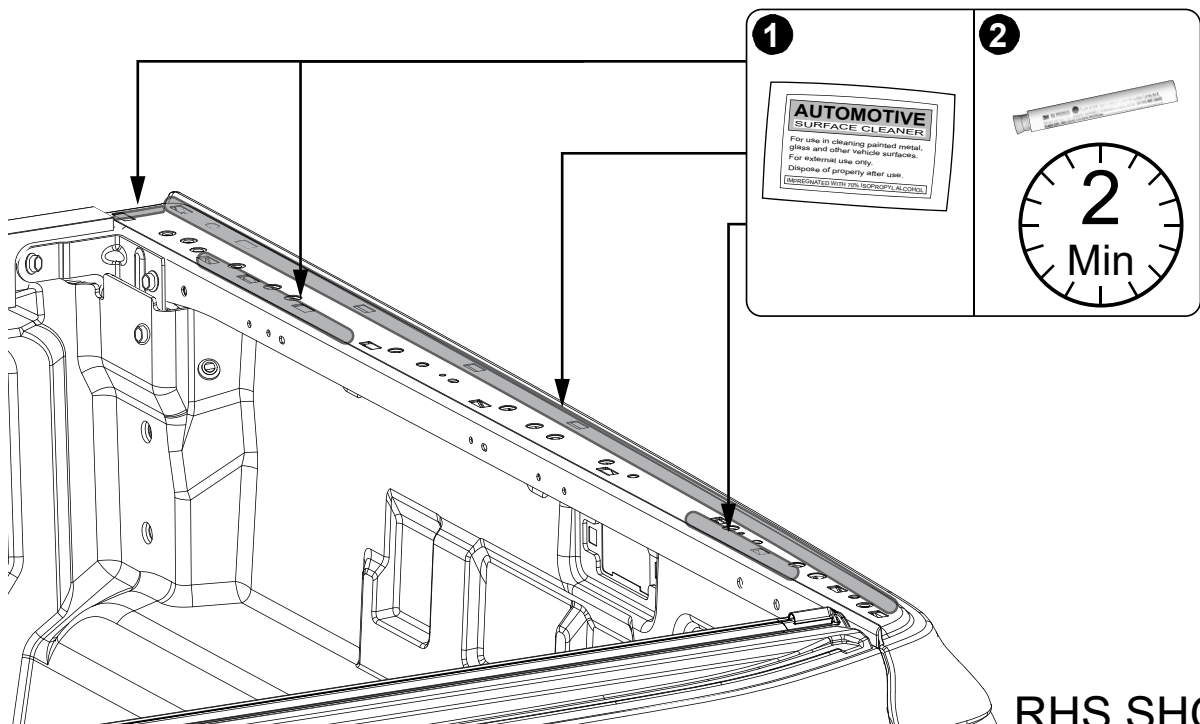

RHS SHOWN

STEP

4

Clean the top of the tub as shown with Alcohol Wipe along the sides. Apply approximately 20mm thick Primer where indicated and wait two minutes.

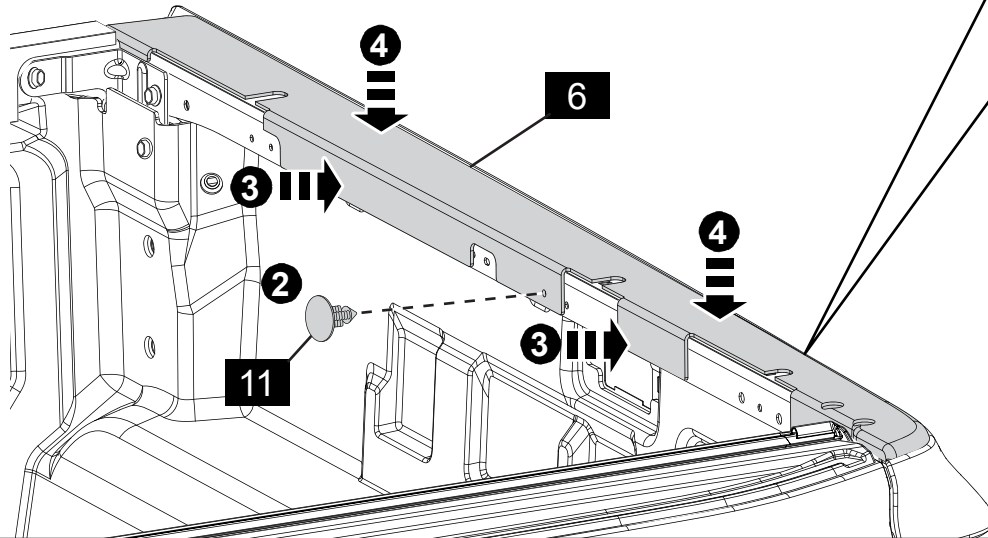
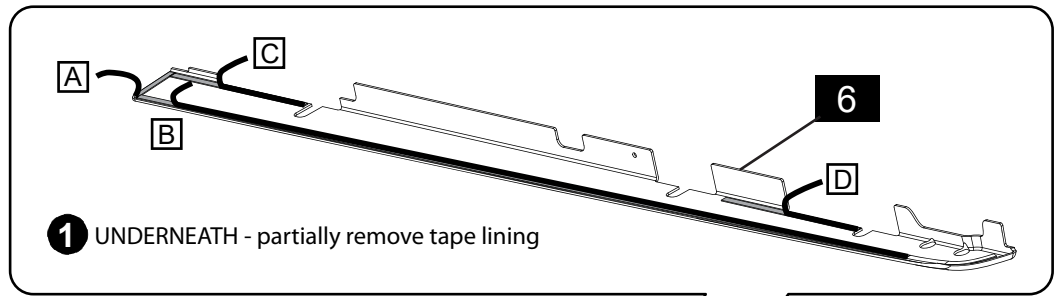

RHS SHOWN

STEP 5 On the Bed Cap (6), peel **A** completely off, partially peel **B**, **C** and **D** by approximately 50mm. Insert the Fir Tree Clip (11) into the Bed Cap (6) and side of the tub using the datum point, ensuring that the top of the Bed Cap (6) does not touch the top of the tub. Press the Bed Cap (6) firmly against the side of the tub, ensure that the Bed Cap (6). Press down the top of the bed Cap (6) and remove the remaining tape lining.

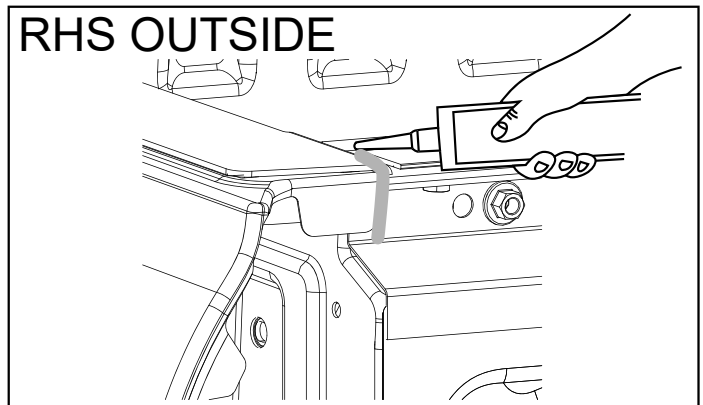
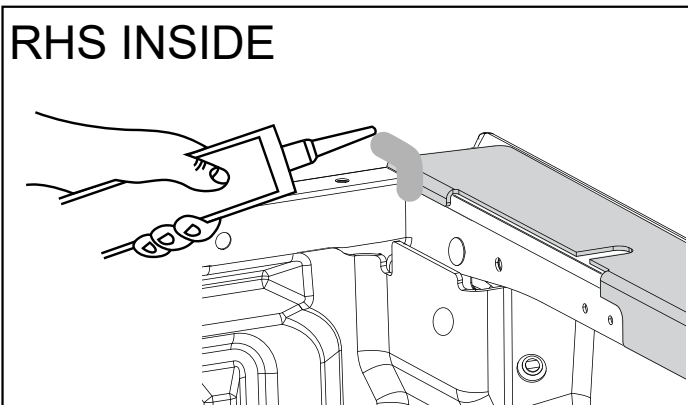
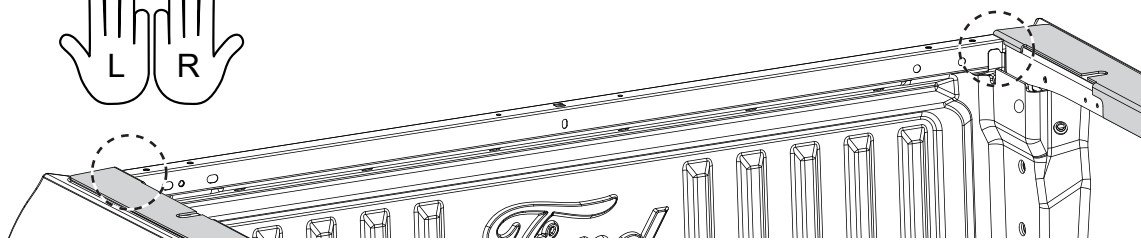

STEP 6 Silicone the gaps indicated at the front of the tub till sealed on both sides. Clean any excess silicone.

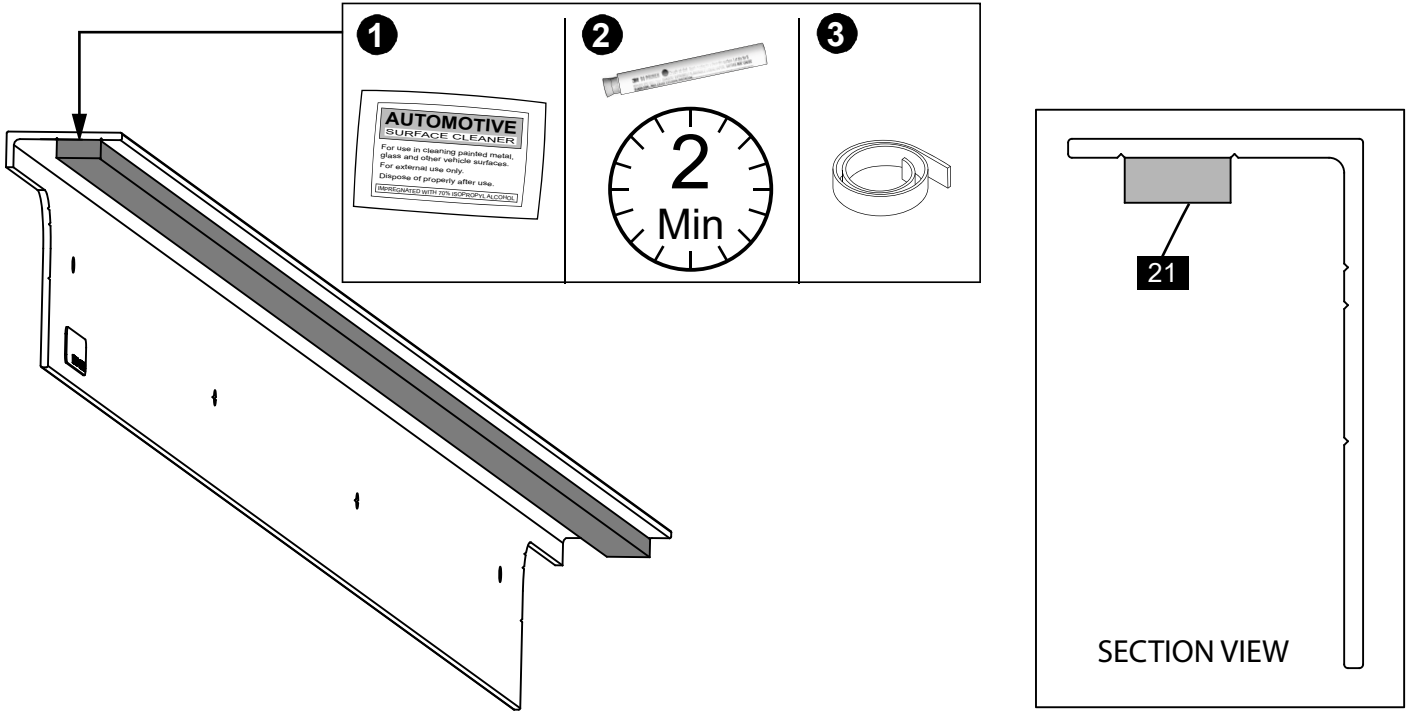

STEP 7 Clean the area under the front header bar with alcohol wipe and apply primer. Apply foam tape (21) as shown in the section view.

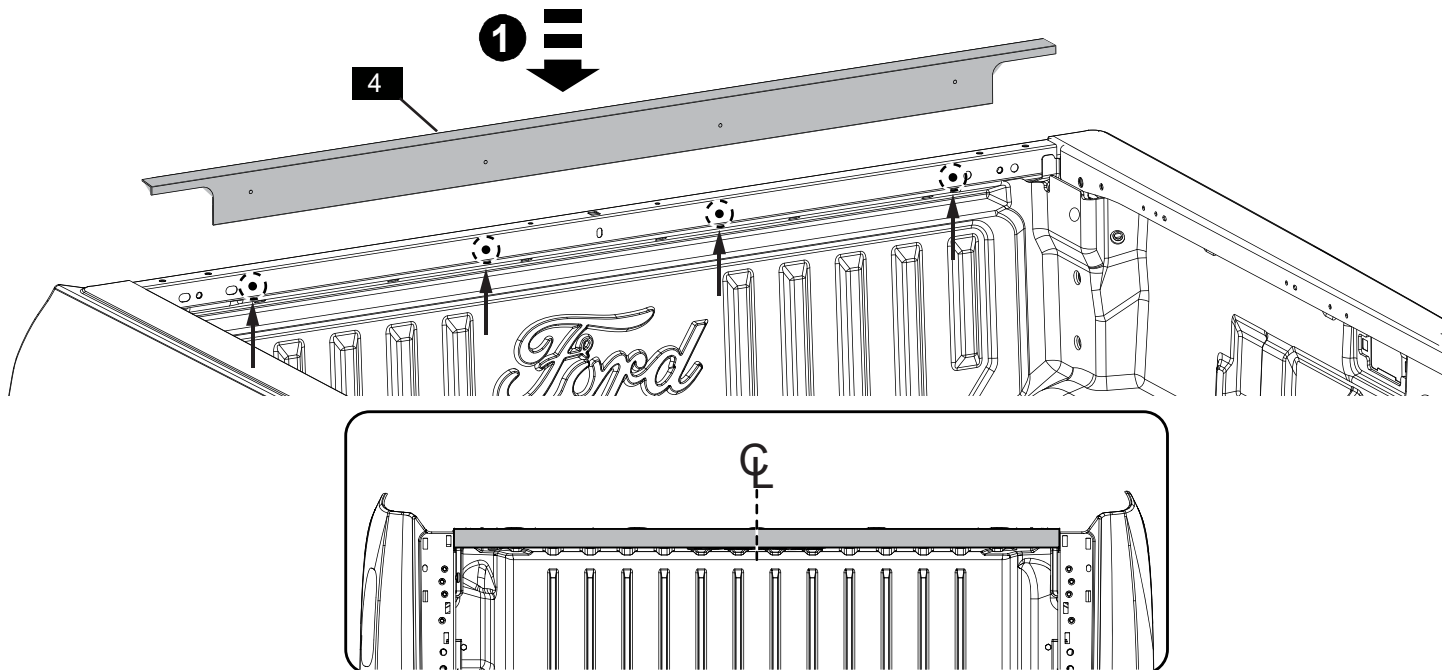
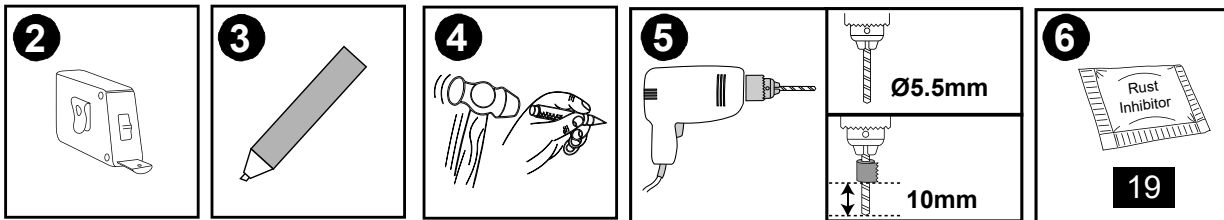

STEP 8 Place Tub Stop (4) on the front of the tub and align centrally, press down to compress the EPDM tape and mark four rivet hole locations using a non-permanent marker. Remove the Tub Stop (4) from the tub. At the marked locations, use a hole punch then drill $\text{\O}5.5\text{mm}$. Apply Rust Inhibitor (19).

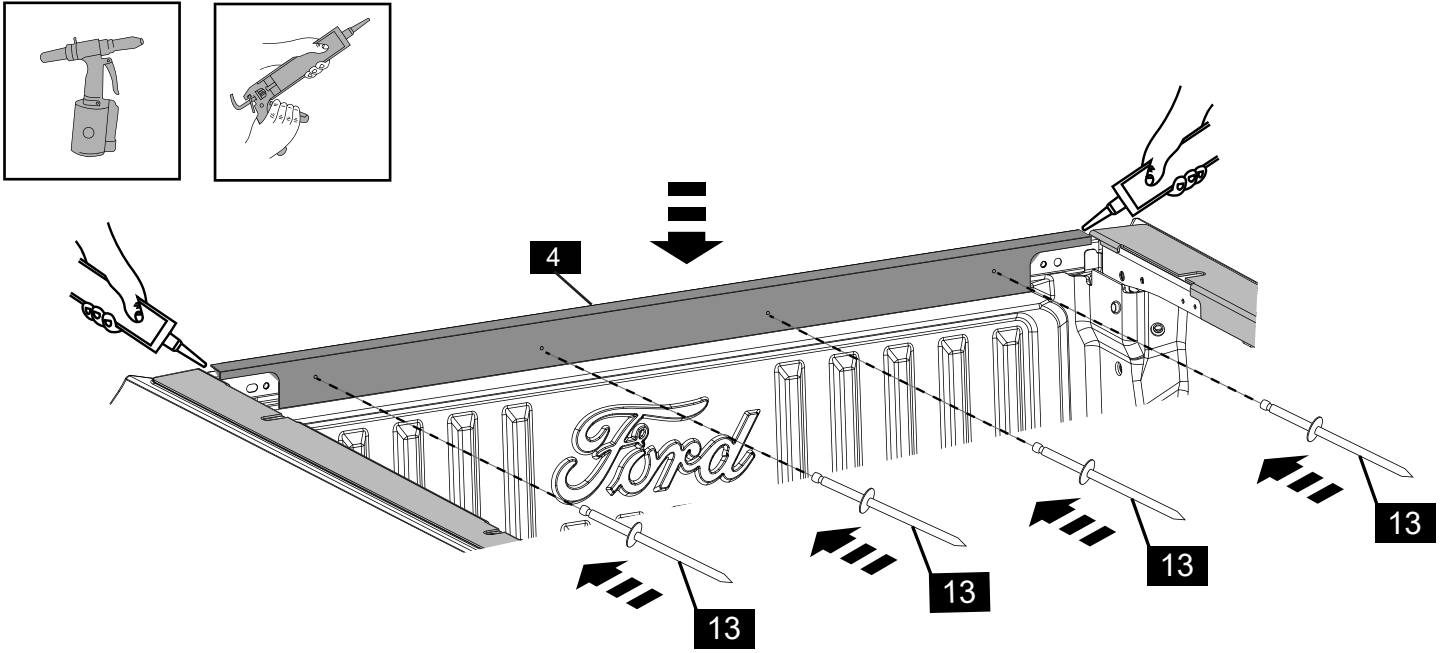

STEP 9 Fit Tub Stop (4) to the tub and align with holes. Secure with four Rivets (13). Seal the gap between the tub stop and side tub caps with silicone. NOTE: Don't have silicone above the parts.

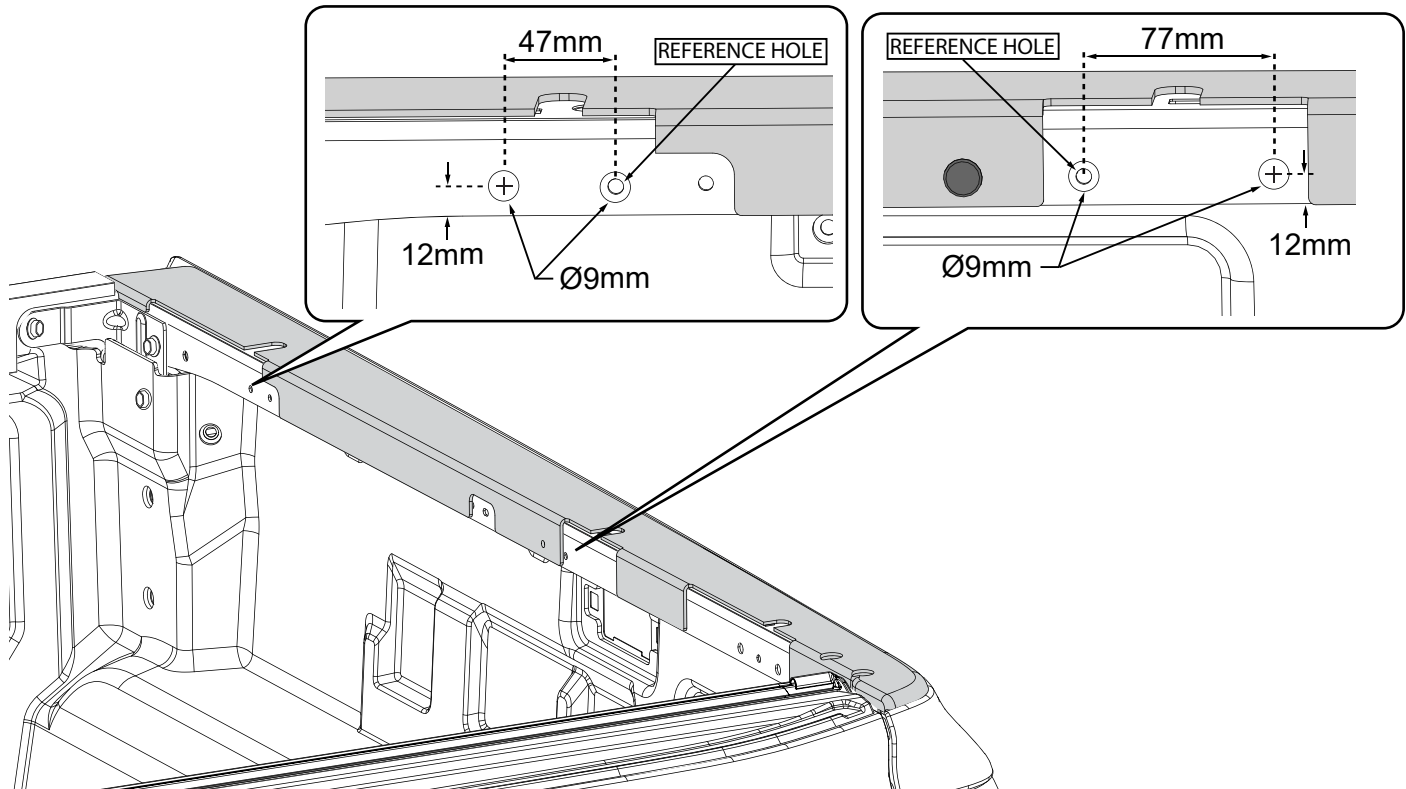
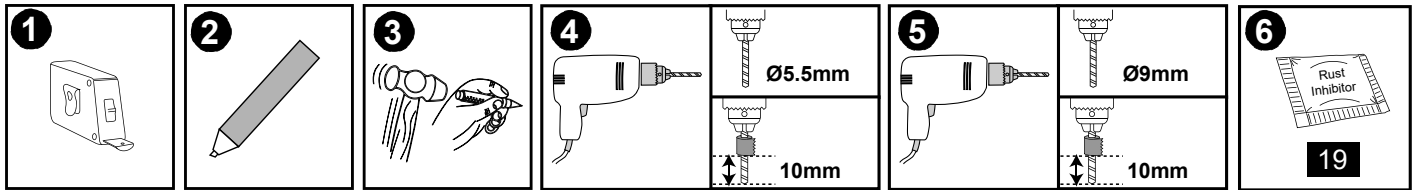

STEP 10 On the RHS of the tub, measure and mark the 2x hole locations as shown. Center punch and drill a Ø5.5mm pilot holes. Drill out the newly created hole and the pre-existing reference hole to Ø9mm. Apply rust inhibitor to both locations. Repeat for LHS.

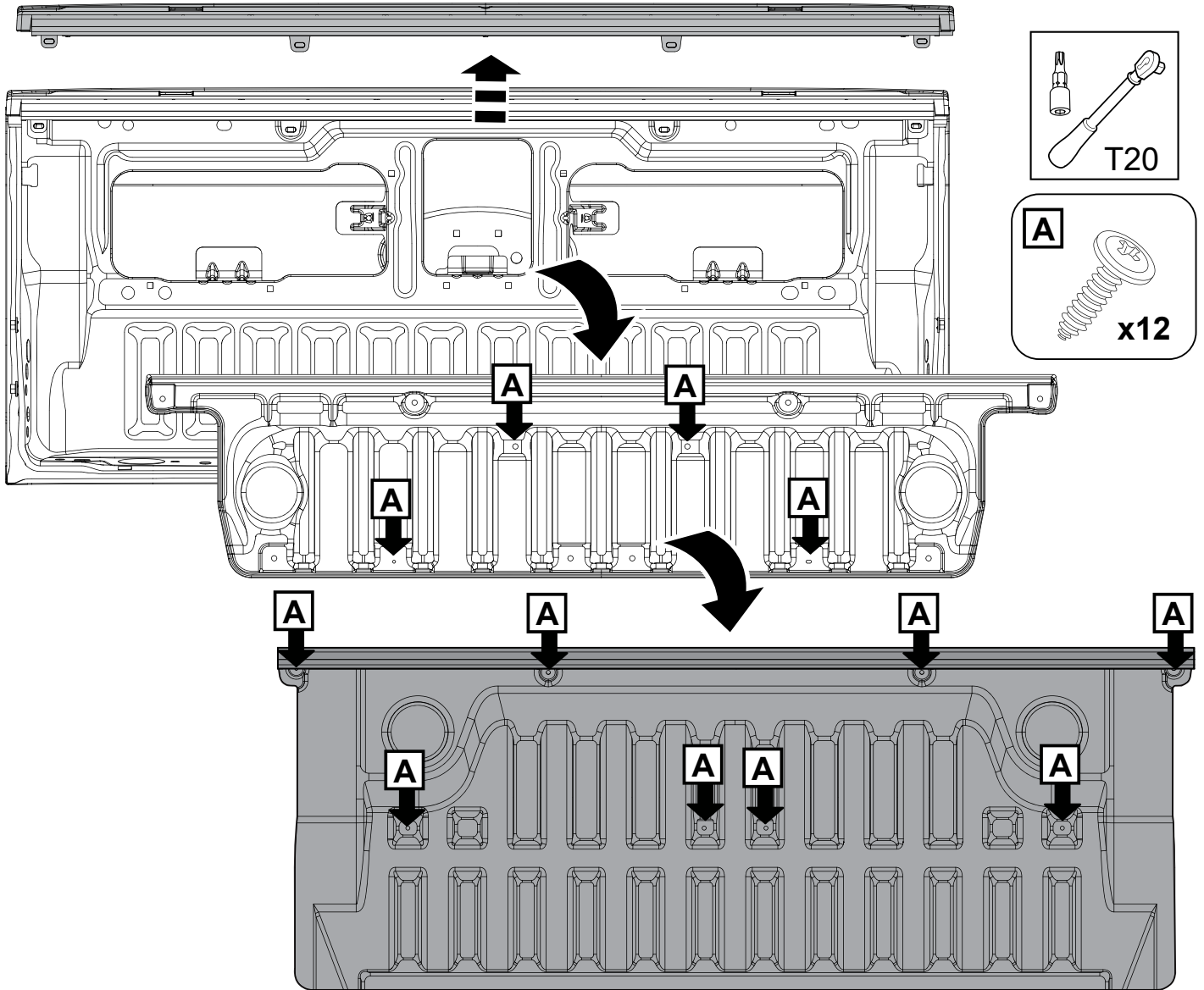

STEP 11 Remove tailgate liner by removing 8 screws (A). Retain all hardware.
Note: Peel the lower rubber extrusion from the tailgate and retain on the liner.
 Remove and retain the tailgate inner cover by removing 4 screws (A). Remove and discard the tailgate top cap.

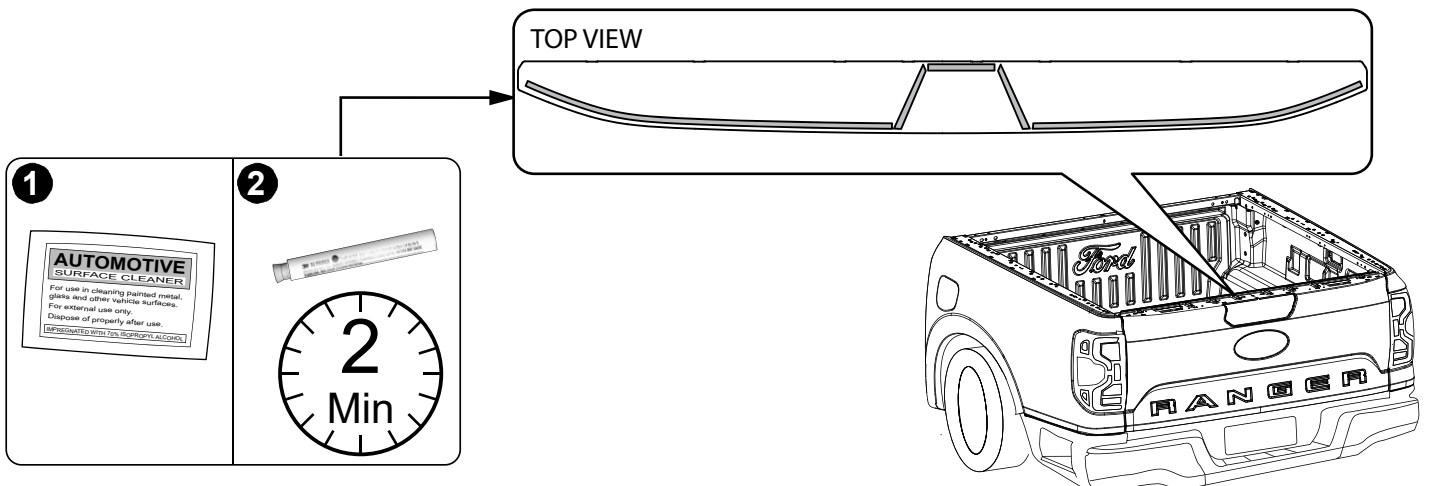

STEP 12 Clean the top of the tailgate surface using an Alcohol Wipe. Prime the surface area indicated with a Primer Stick and wait 2 minutes before proceeding.

UNDERNEATH - Remove tape protector

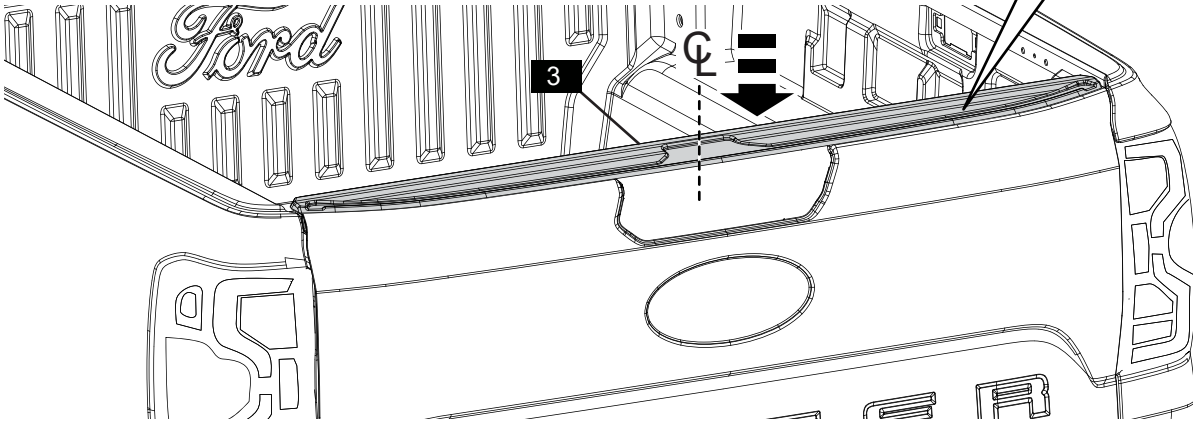
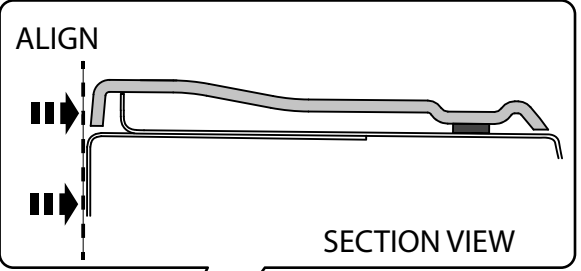
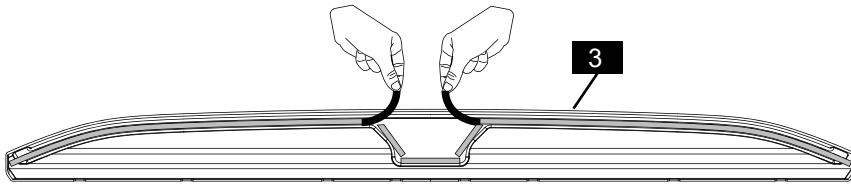

STEP 13 Peel the tape protector from the Tailgate Cap (3) approximately 50mm on each side and completely off for the small tabs in the center. Place the Tailgate Cap (3) on top of the tailgate and ensure that it is centrally aligned, as well as positioning rearwards (see section view). Push the Tailgate Cap (3) firmly to ensure full adhesion of the exposed tape. Peel remaining tape liner away from the center of the Tailgate Cap (3).

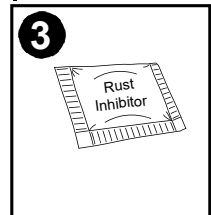
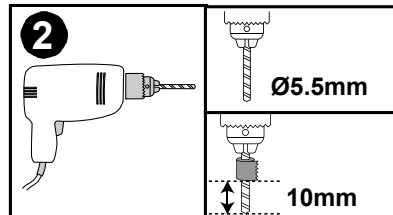
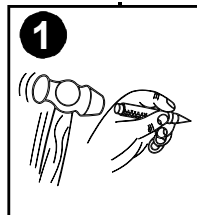
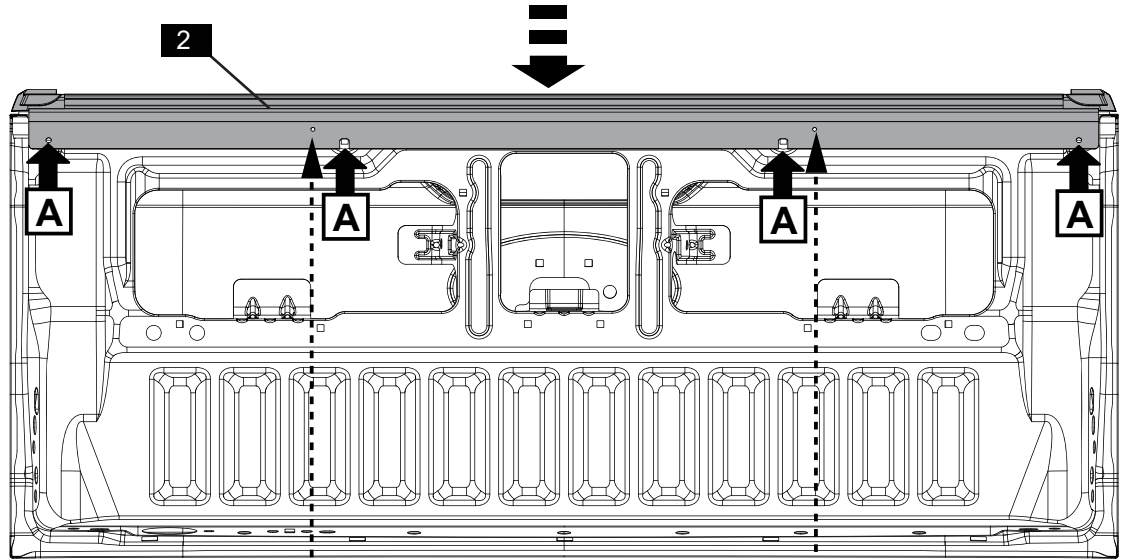
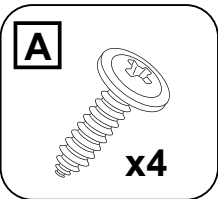
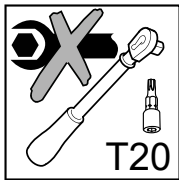

STEP 14 Place the Tailgate Extrusion (2) on the tailgate and align with screw holes. Secure with 4x previously removed screw as shown. Mark the holes for two rivets using a non-permanent marker. Unscrew the 4x torx screws. Remove the Tailgate Extrusion (2). Center punch the two marked holes, drill Ø5.5mm and apply rust inhibitor.

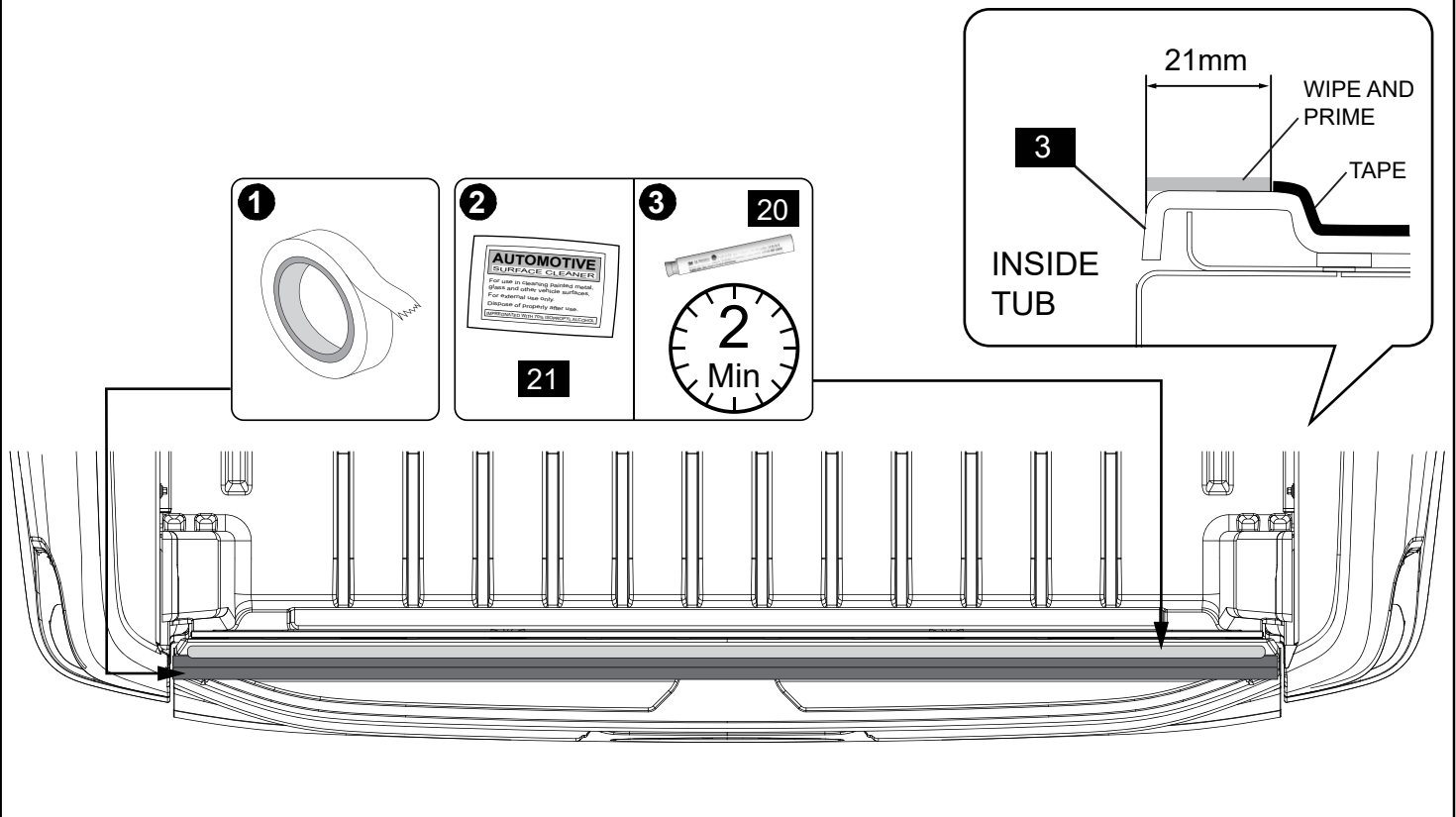

STEP 15 Apply masking tape past 21mm from inside edge to protect the tailgate cap surface. Clean Tailgate Cap (3) with Alcohol Wipe (21) then Prime (20) the area indicated and wait 2 minutes. After 2 minutes, remove masking tape.

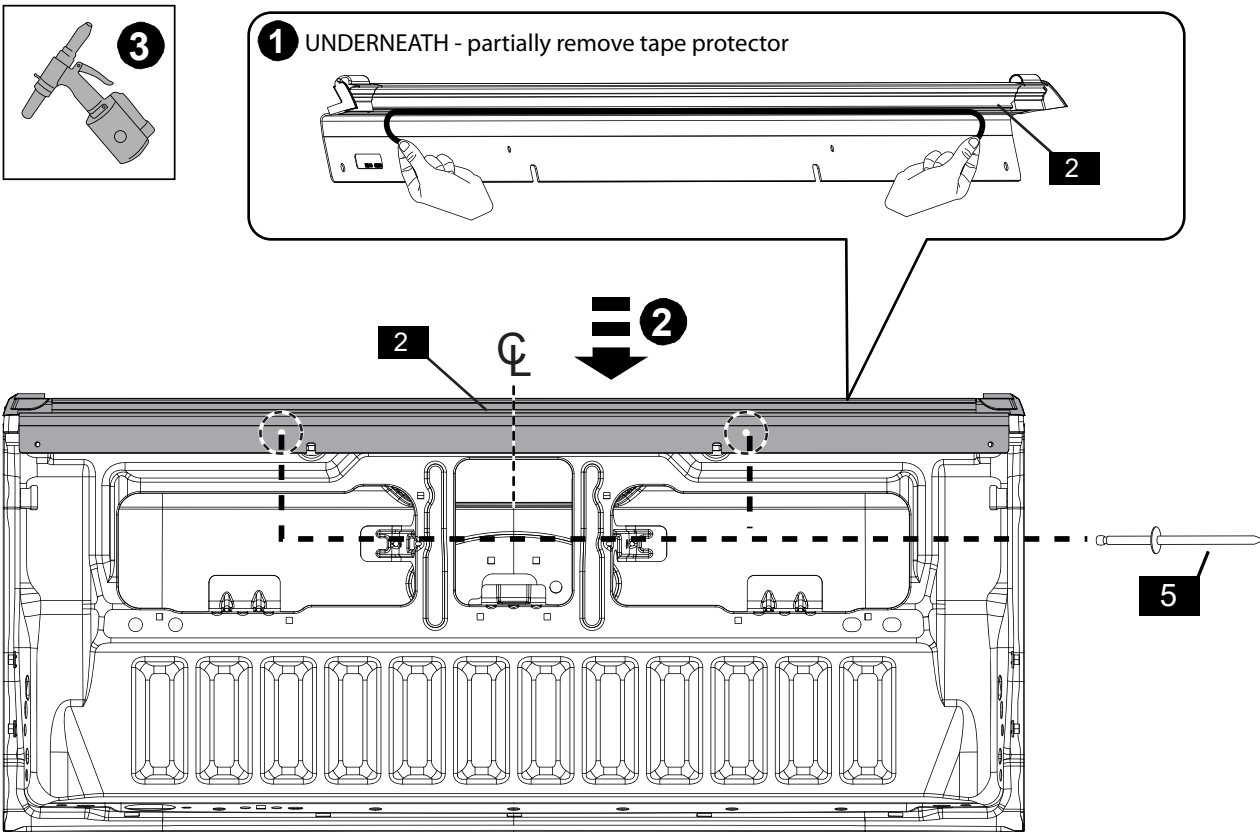

STEP 16 Remove approximately 50mm of tape protector from underneath the Tailgate Extrusion (2). Place the Tailgate Extrusion (2) onto the tailgate and align the holes. Compress the Tailgate Extrusion and remove tape protector starting from one side. Secure the extrusion with 2x Rivets (5).

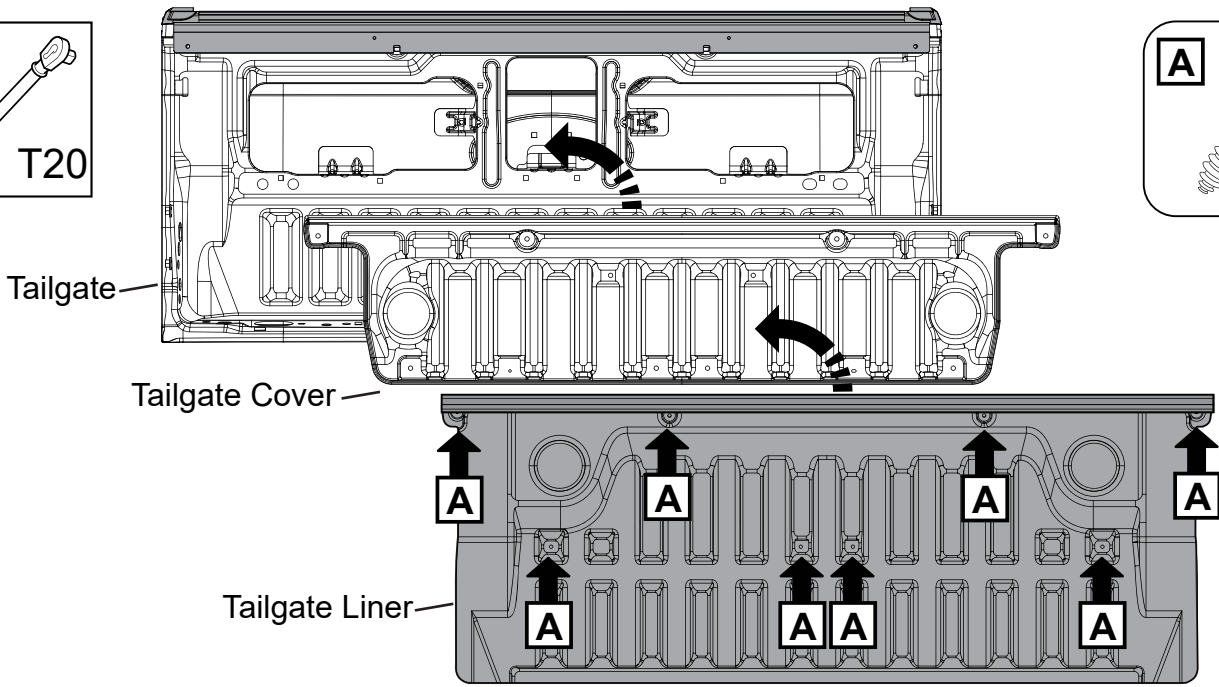
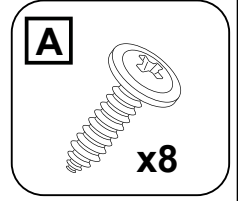
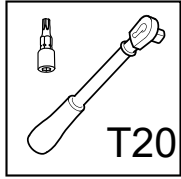

STEP 17

Install the previously removed tailgate cover and liner (if applicable) to the tailgate using 8x previously retained screws.

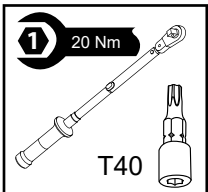

RHS SHOWN

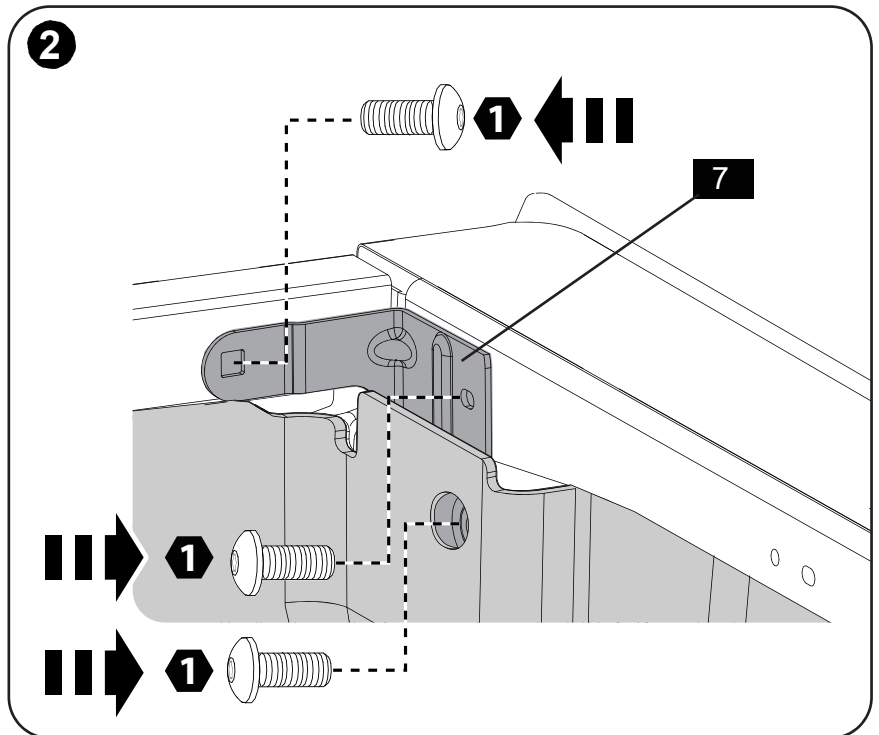
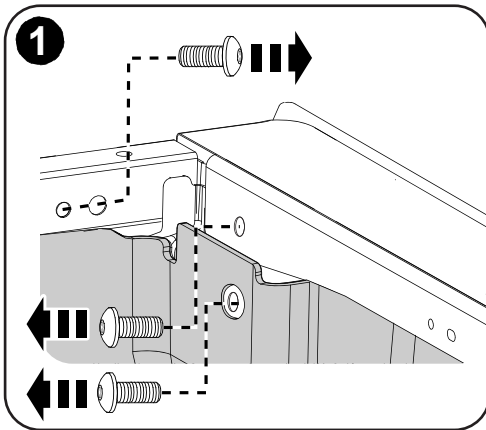

STEP 18

Remove 3x torx screw from tub and retain. Place the Front Reinforcement Bracket (7) underneath the tub liner (if applicable) and secure with 3x torx screws previously removed. Torque to 20Nm.

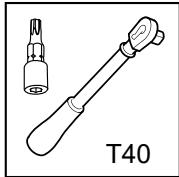
**PERFORM THIS STEP ONLY IF UTILITY RAIL IS FITTED**

T40

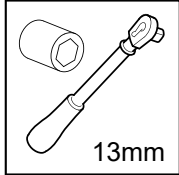

13mm

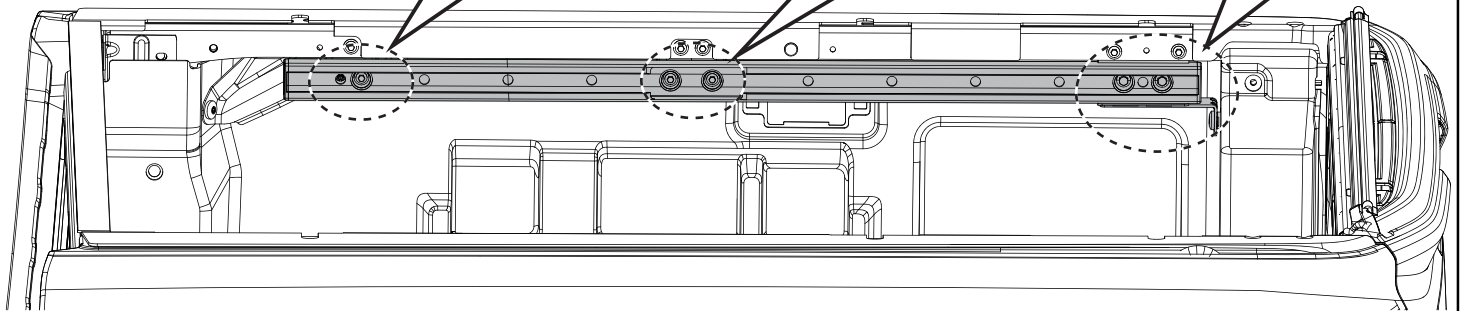
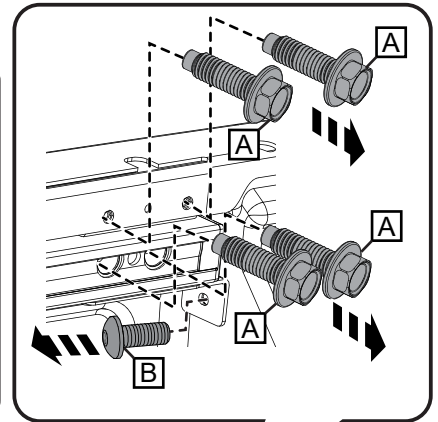
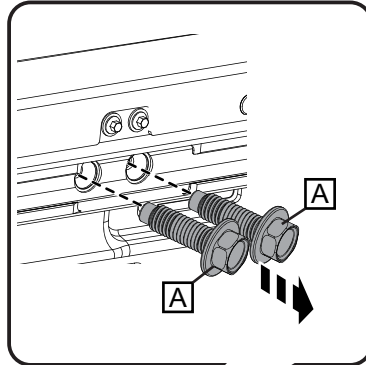
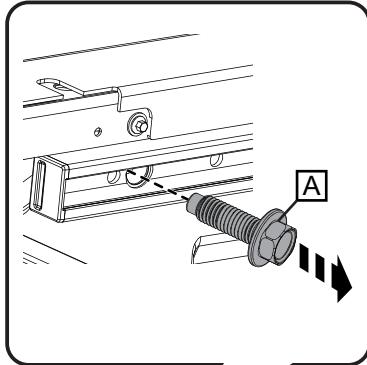
**RHS SHOWN**

STEP 19 If utility rail is present, remove utility rail and retain shown hex head screws (A) and torx screw (B). If utility rail is not present, remove torx screw located at the rear of the tub and proceed to the following step.

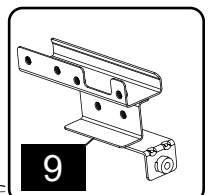
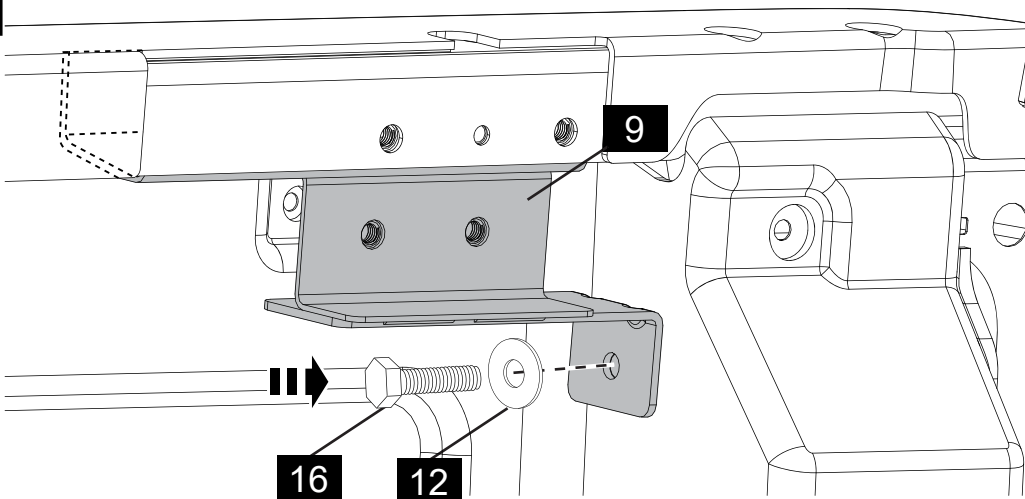
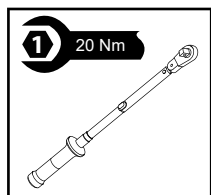
**RHS SHOWN**

STEP 20 Install Rear Support Bracket (9) as shown on the RHS using M8 screw (15). Torque to 20Nm.

! PERFORM THIS STEP ONLY IF UTILITY RAIL IS FITTED

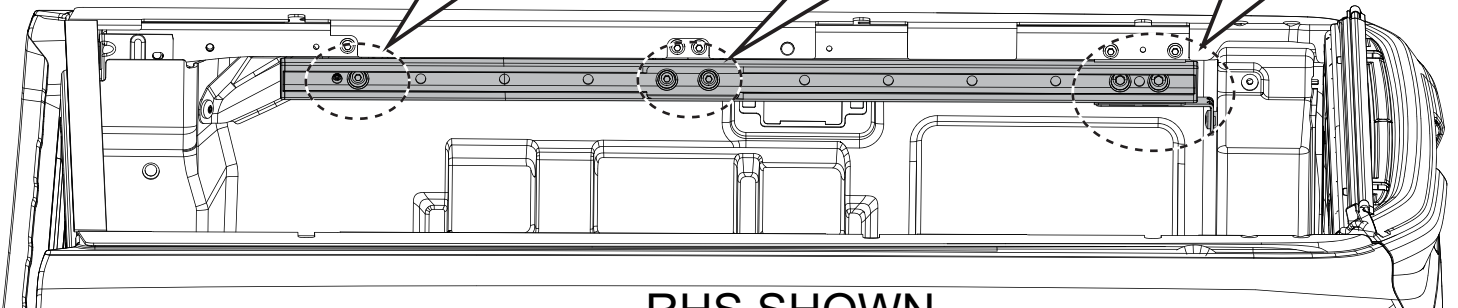
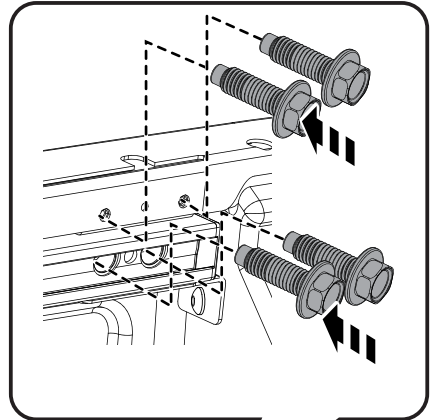
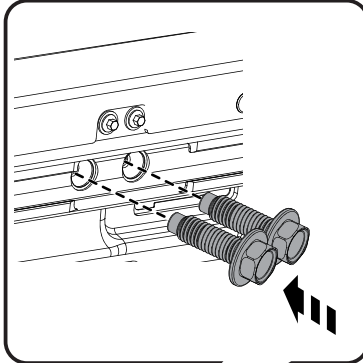
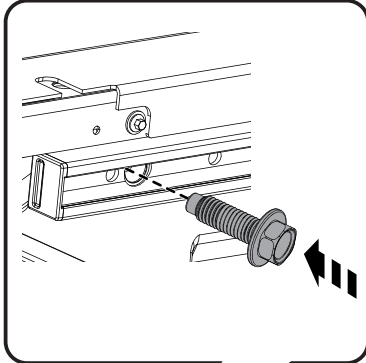
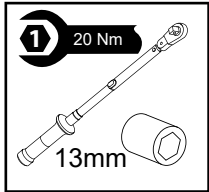

RHS SHOWN

STEP 21

Secure the utility rail using previously retained hardware. Torque to 20Nm.
Note: if the utility rail is not present, proceed to next step.

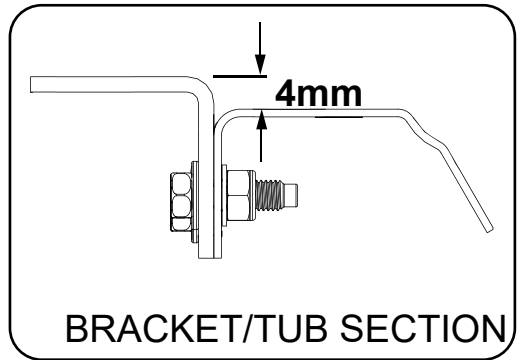
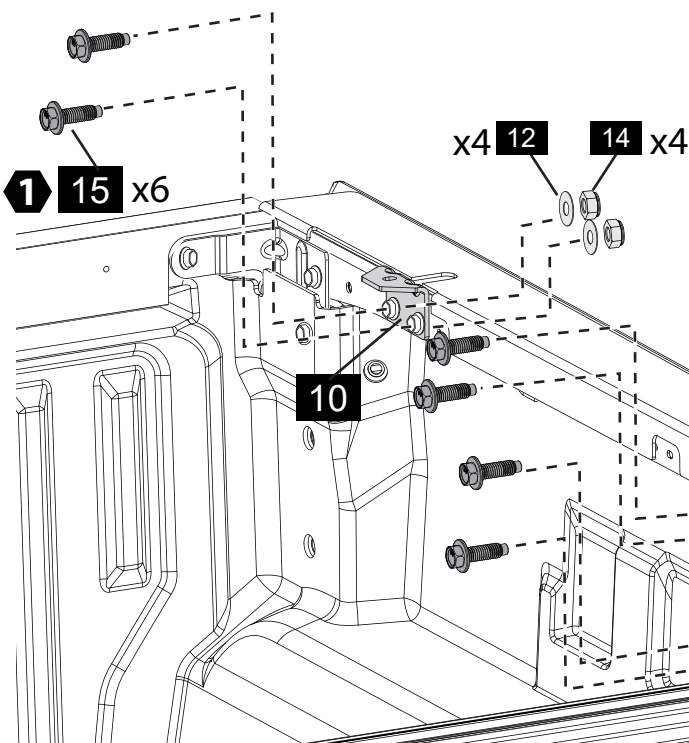
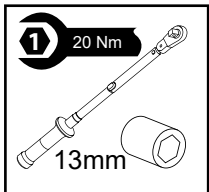

STEP 22

Install the Front (10), Mid (8) and Rear (8) brackets as shown using 6x Hex Screws (15). Torque to 20Nm.
Note: Set the brackets height to be 4mm above the bed cap level.

CANOPY FITMENT

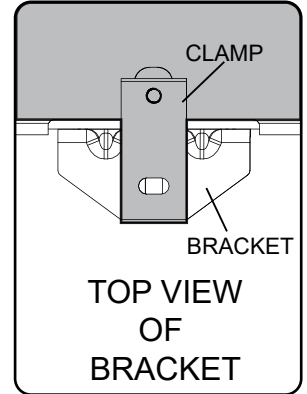
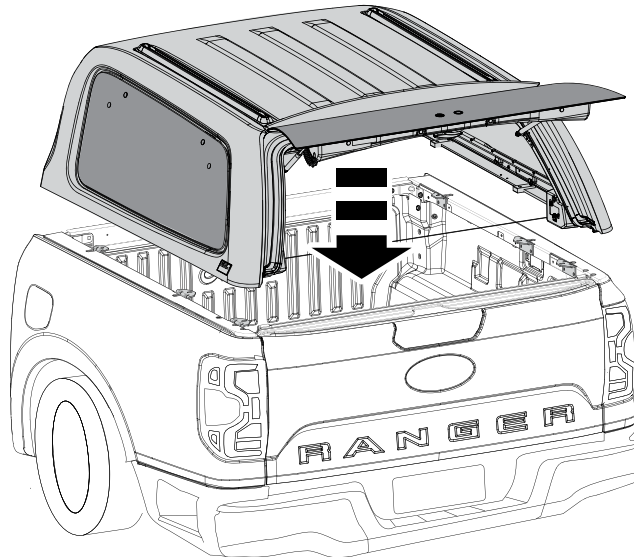

STEP 23 With the Canopy's rear door open, place it gently onto the tub using 4 people and align it to the holes on the brackets in 6 locations as shown.

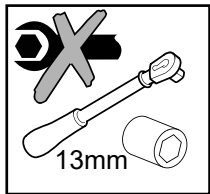

Some parts of canopy are not shown for clarity

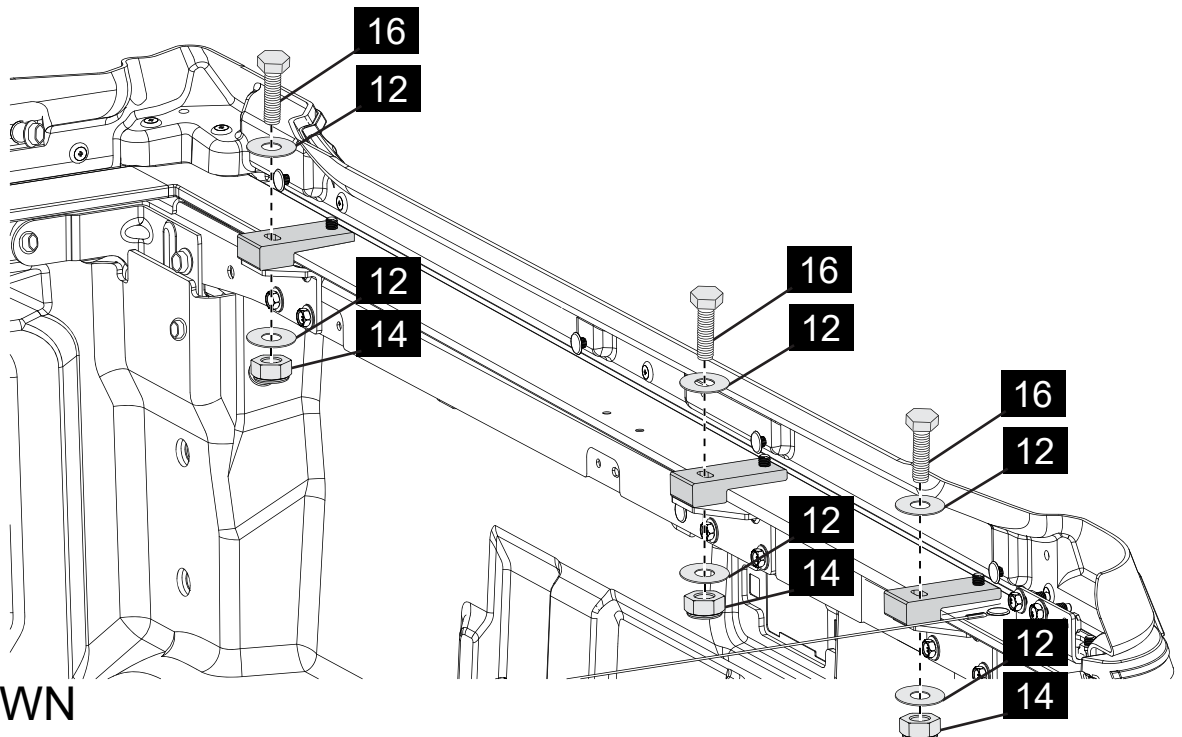

STEP 24 Inside the canopy, secure all clamps to the brackets previously added to the tub using 1x Hex Screw (16), 2x Washers (12), and 1x Nut (14) for each pairing.
Note: Loosely fit, do not tighten.

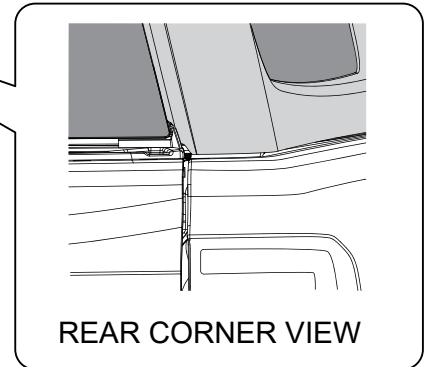
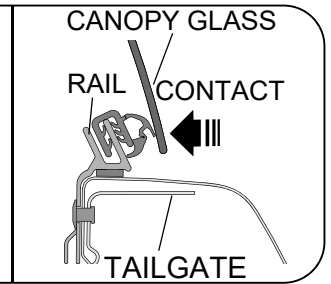
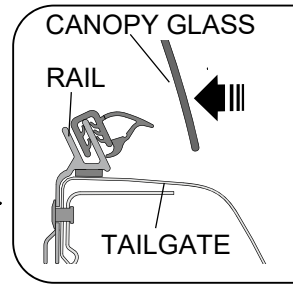
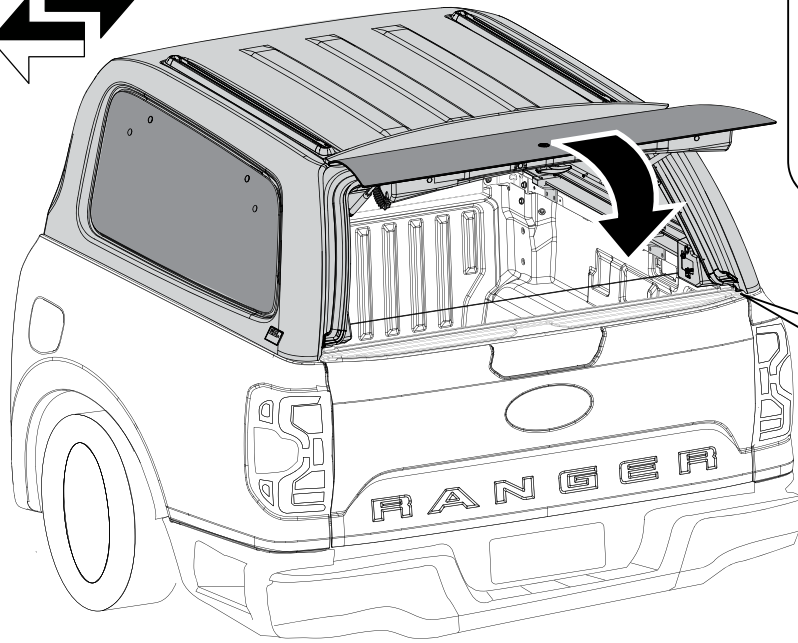

STEP 25 With one person inside the Canopy, slowly close the rear canopy window, and note how it closes. It should not touch the top of the tailgate and fully compresses the rubber extrusion of the tailgate rail. Check corner alignment, ensure that the canopy body does not hang on the tailgate and sits as shown. Adjust if necessary.



Some parts of canopy are not shown for clarity

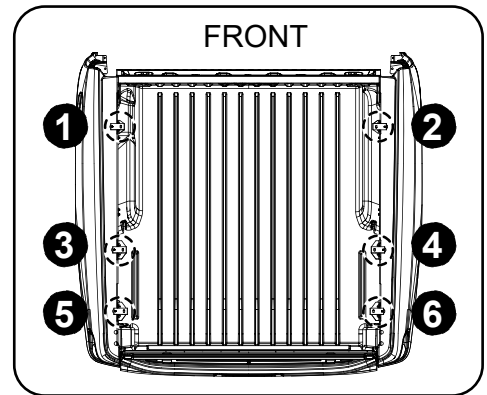
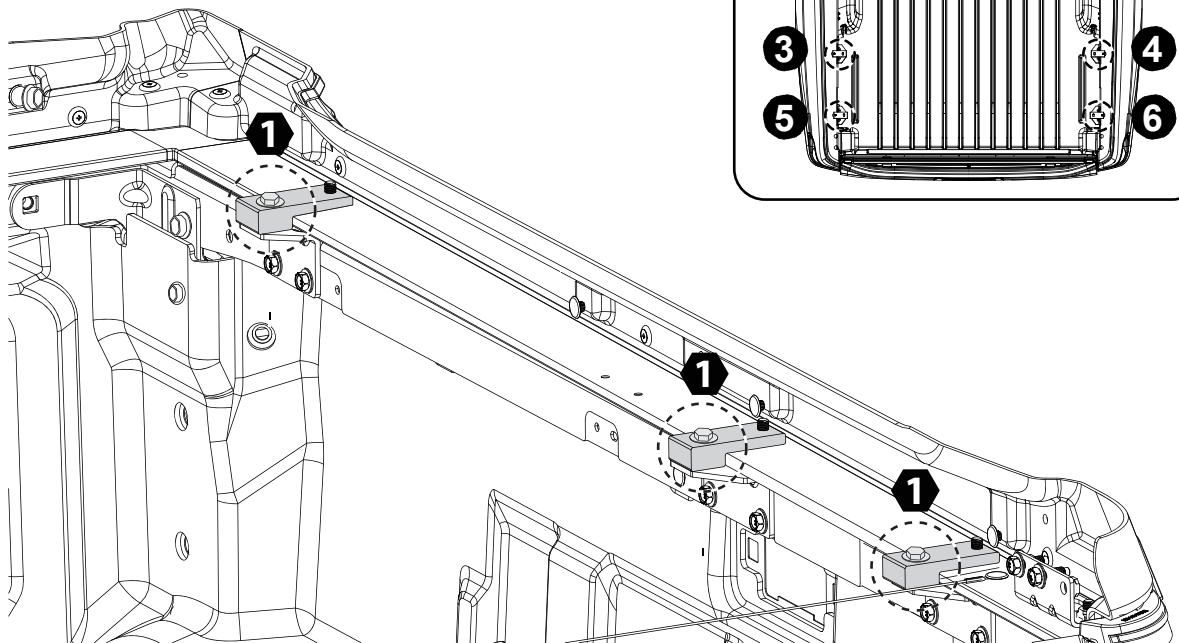

RHS SHOWN

STEP 26 Torque 6x Hex Screws (16) to 20Nm in sequence shown.

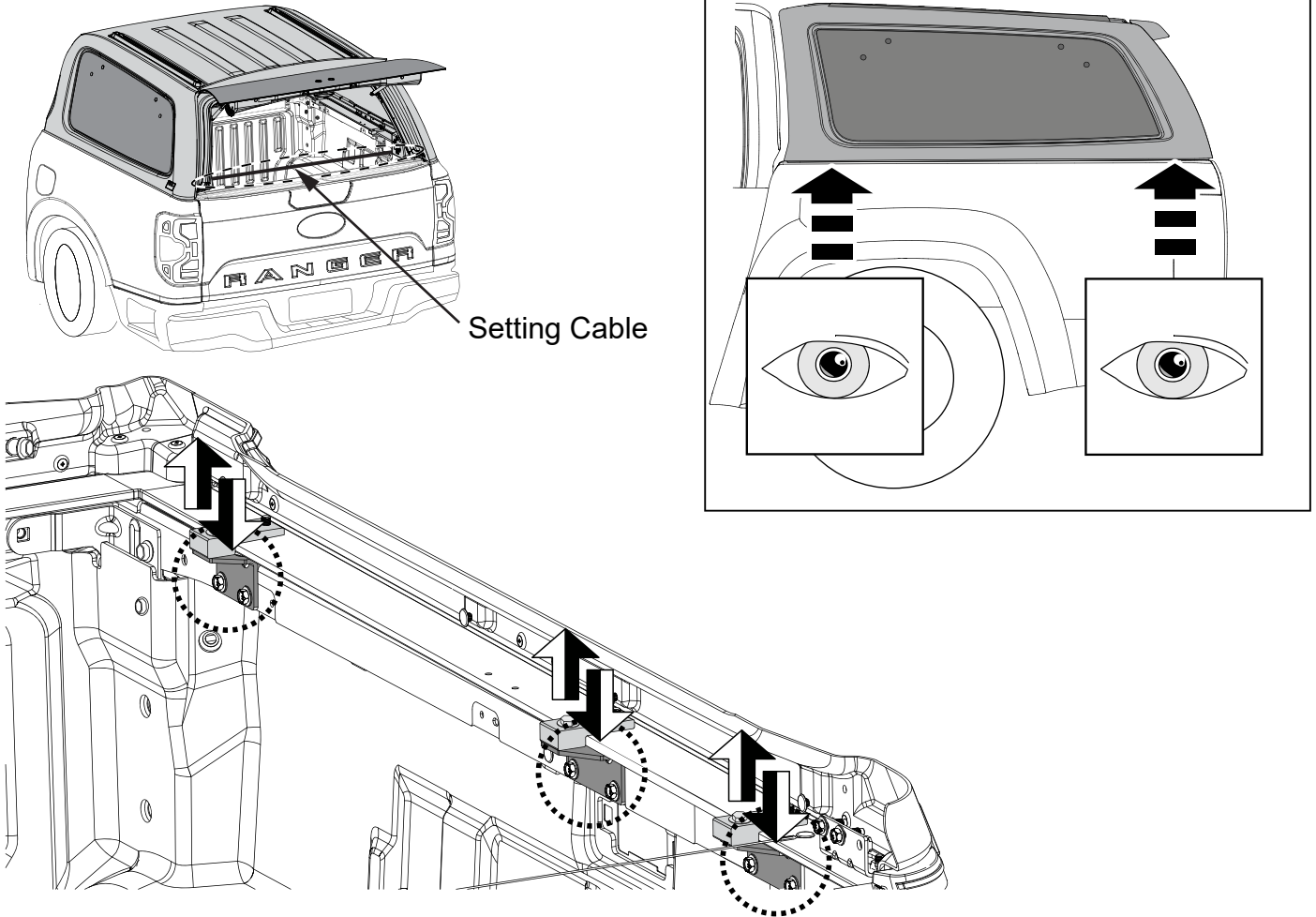

STEP 27 Visually check the canopy side level. To adjust the level, lower or lift the 3 side brackets on the required side of tub. Loosen the M8 bolts holding brackets and torque to 20Nm after adjustment. Remove the setting cable from the canopy by removing the scrivets from either side.

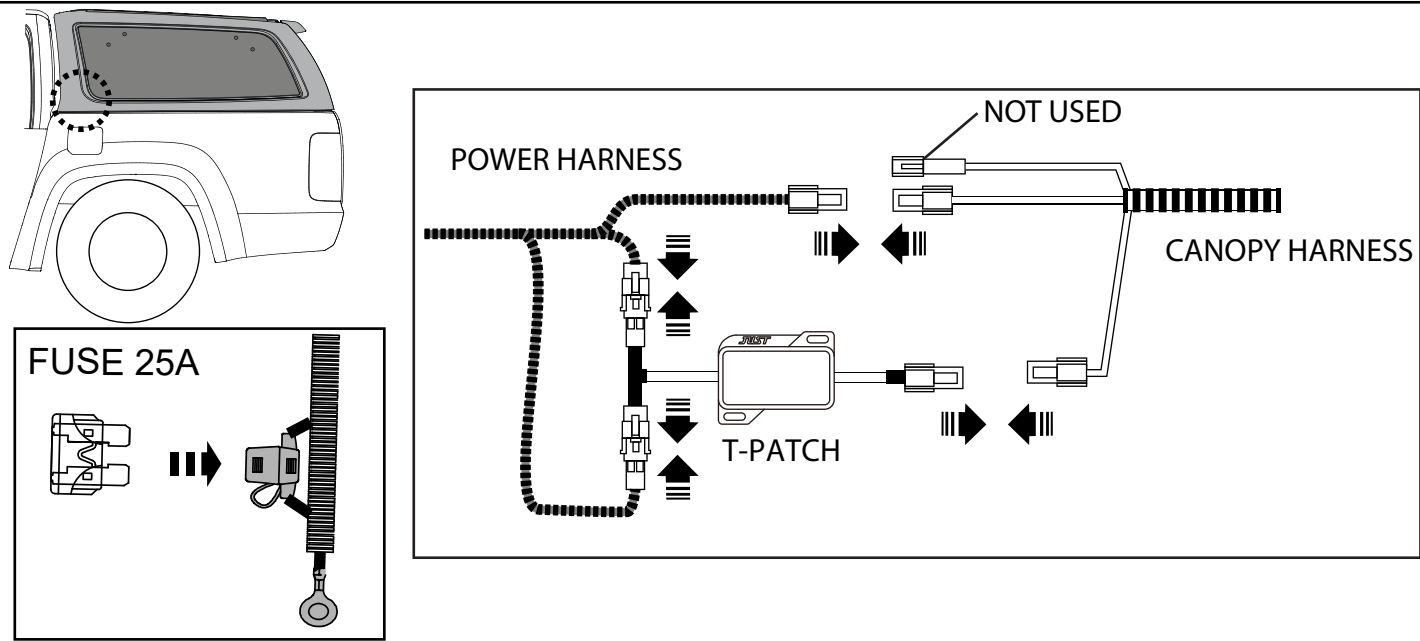

STEP 28 Connect the T-patch unit to the Power Harness and the canopy harness as shown. Reconnect the negative battery terminal. Install previously removed and retained fuse into the positive fuse terminal on the Vehicle Harness. Lock and unlock vehicle once to kick the ECU into action. Check the function of the canopy central locking, brake lights and interior lights.

GEN 3 PREMIUM STRIKER ADJUSTMENT GUIDE

1. Check that the Striker on both sides of the canopy closes correctly. The Latch Cam is a single stage locking mechanism.

Listen for a single distinct click from each side of the canopy window when locking or unlocking the window.

If the Latch Cam does not produce a click on either side of the window, the Striker is not engaging the Latch Cam correctly.

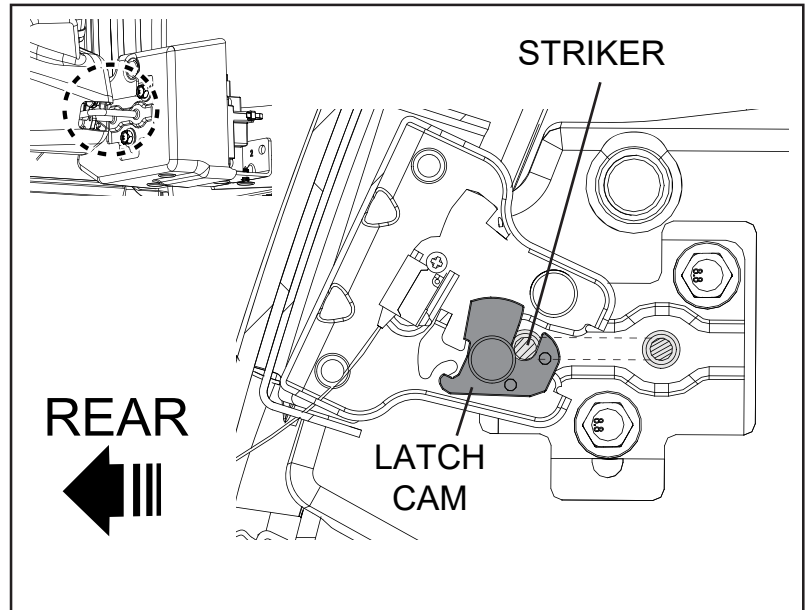

2. If the striker is not engaging the latch, the depth or height of the Striker will need to be adjusted.

To adjust, slightly loosen the adjustment bolts, and move the striker incrementally horizontally or vertically.

Appropriately tighten the bolts and test the mechanism after each incremental change. The Striker should be centrally aligned with the Latch Cam. The Latch Cam should not catch or scrape the Striker on engagement or release. If catchment is occurring, readjust the Striker.

Once desired result is achieved, torque the striker adjustment bolts to 20Nm.

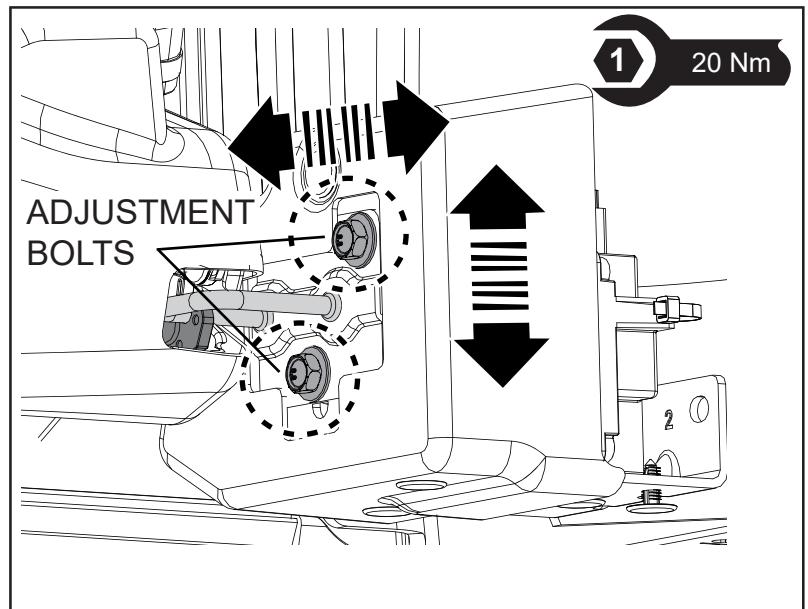

3. Carefully close the window, ensuring the glass does not contact the tailgate. Ensure there is a minimum 9mm gap (15mm max) between the glass and the top of the tub.

For an appropriate seal and correct latching to occur, the clearance gap must be within the values specified and also be approximately equal on both sides of the canopy. Adjust accordingly.

Example:
If the LHS clearance gap is 12mm, the RHS clearance gap must be $12 \pm 3\text{mm}$.

If the rear window glass clearance measures outside of the above-mentioned min (9mm) and/or max (15mm) values, please contact EGR After Sales Support.

