

FORD RANGER MY22 ➔

Installation Time: Approx. 45 mins (without tub liner)
1.0 hour (with tub liner)

Important



- Read instructions carefully before installation.
- It is strongly recommended that installation is conducted by an authorized dealer.
- This product must be installed exactly as specified in these instructions. Failure to do so may result in improper fit and/or retention/failure of components.

PERSONAL PROTECTIVE EQUIPMENT:



Mask



Rubber Gloves



Goggles



Hearing Protection

Care Instructions:



Clean with a mild detergent and water solution.



Do not use abrasive cleaners or solvents.

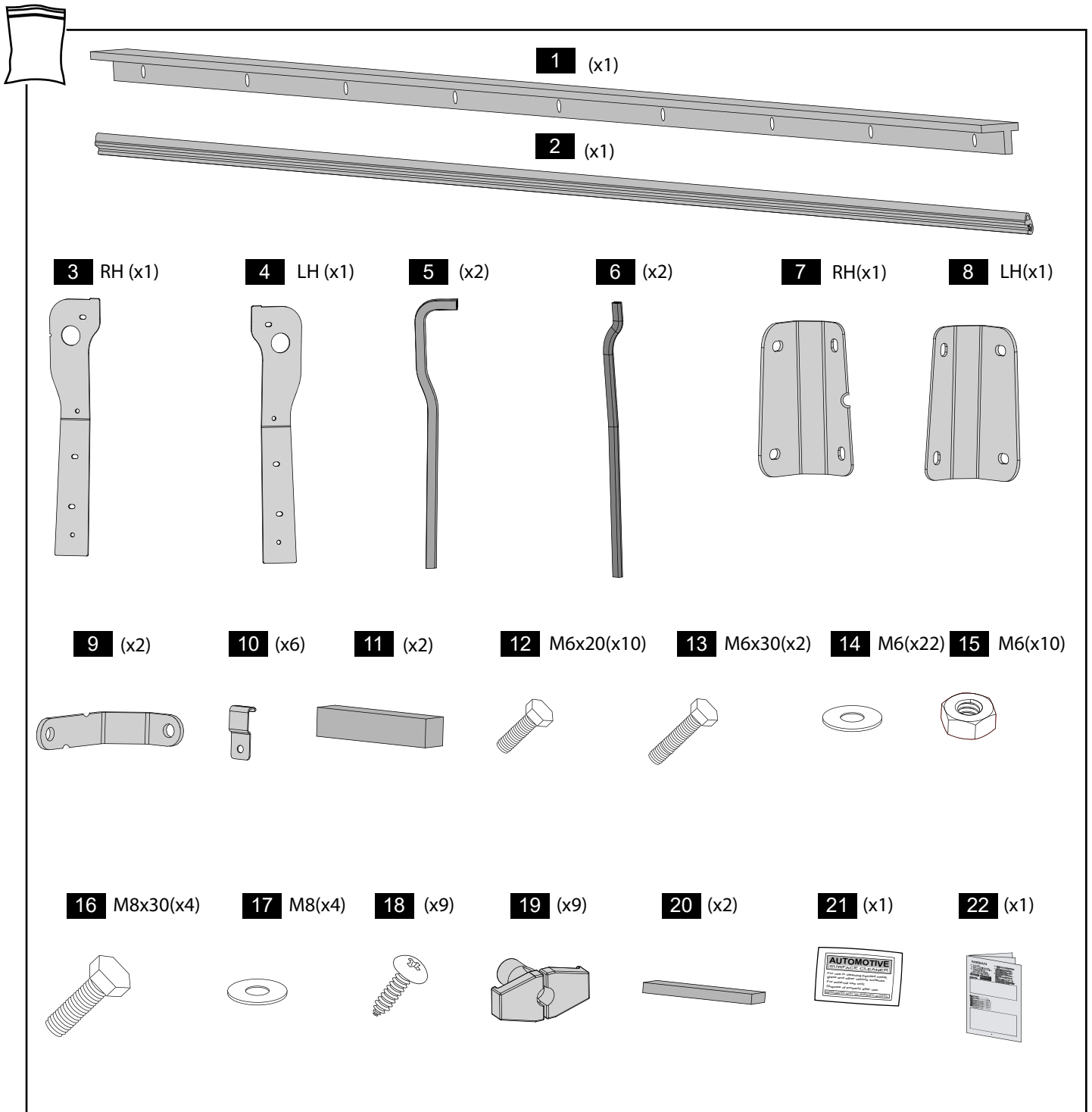

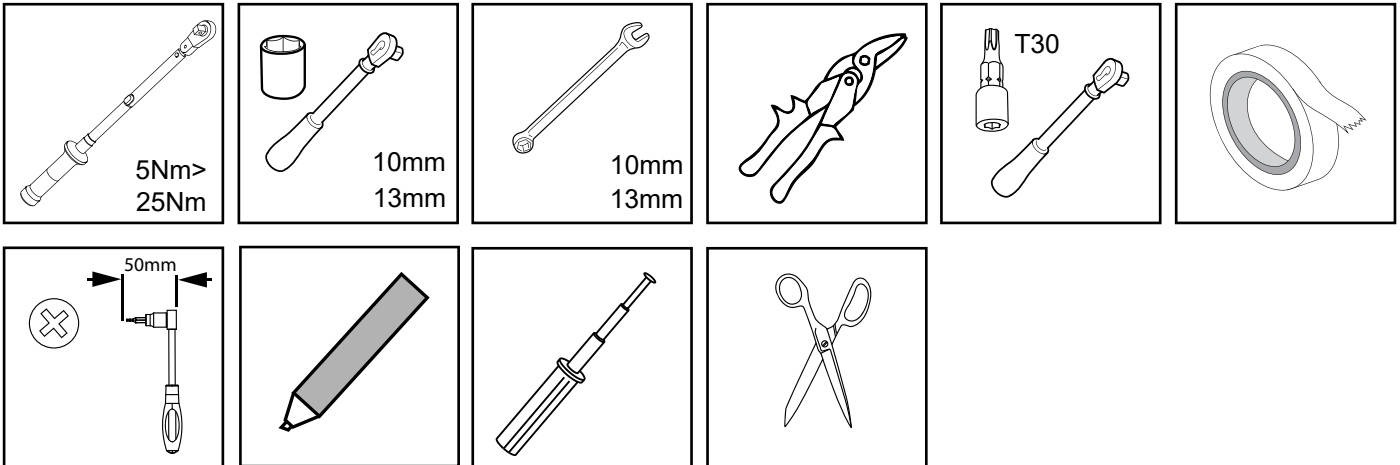
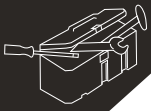

GLOSSARY

	: Vehicle Part		: Location
	: Sequence		: Loosen
	: Part Provided		: Adjust
	: Torque Setting		: Install & Remove
	: Even Space		: Equal
	: Reuse		: Disconnect
	: Discard		: Connect
	: Complete for Both Sides		: No Torque
	: Two People		: Lock
	: Check		: Unlock
	: Caution		
	: Clean		

1

TUBLINER TRIM (IF FITTED)

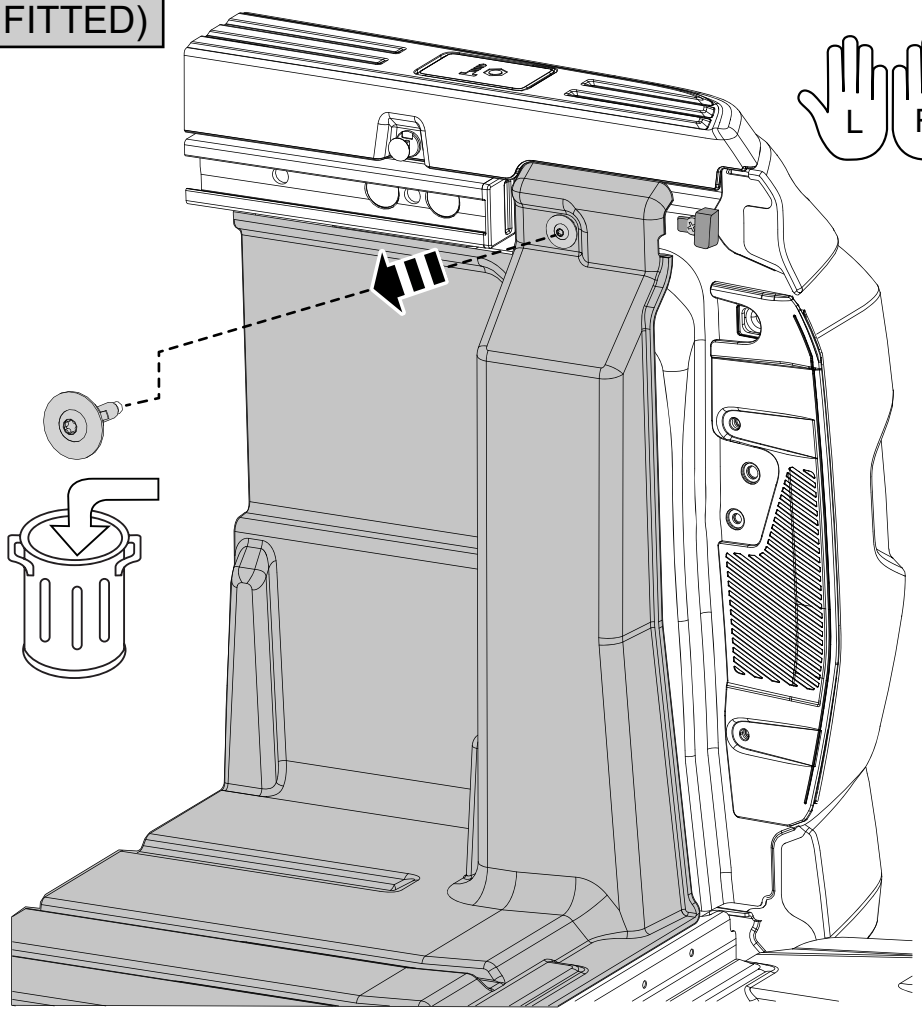
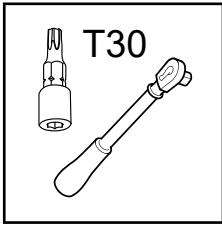

2

TUBLINER TRIM (IF FITTED)

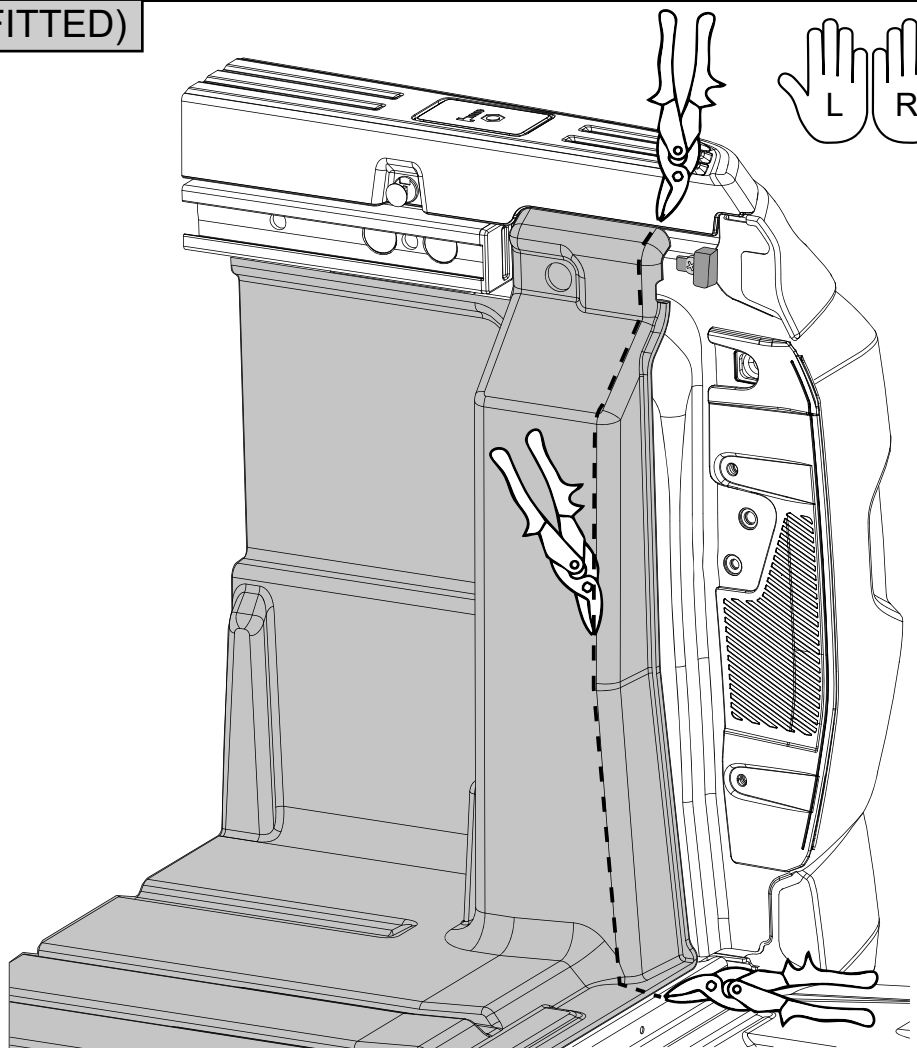
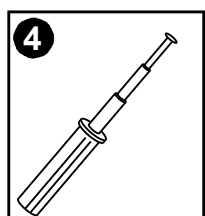
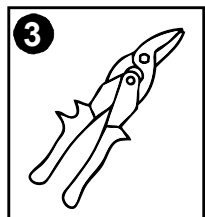
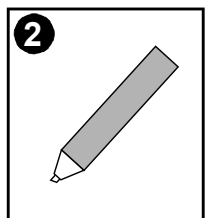
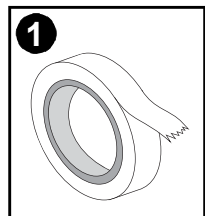

3

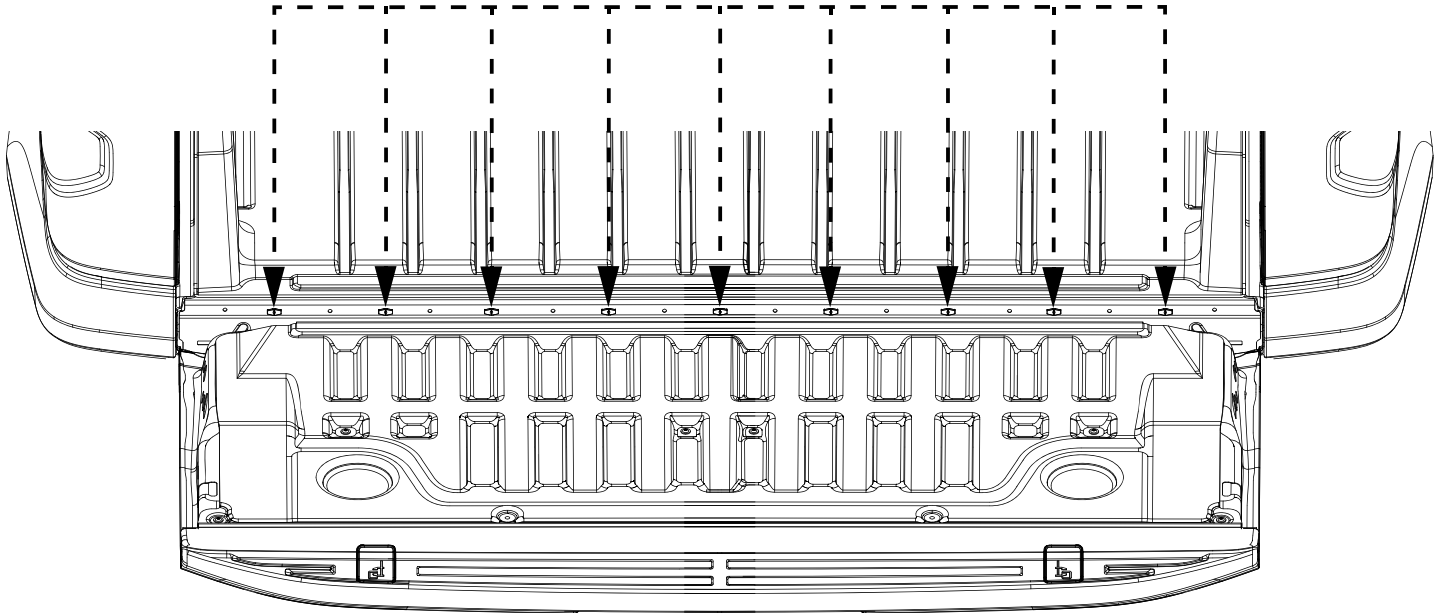
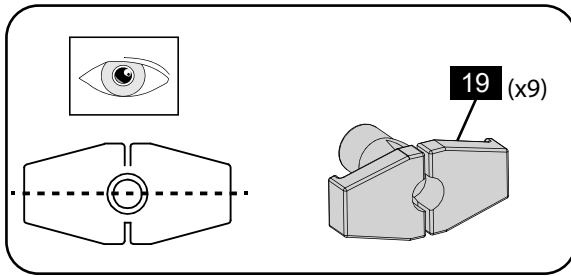

4

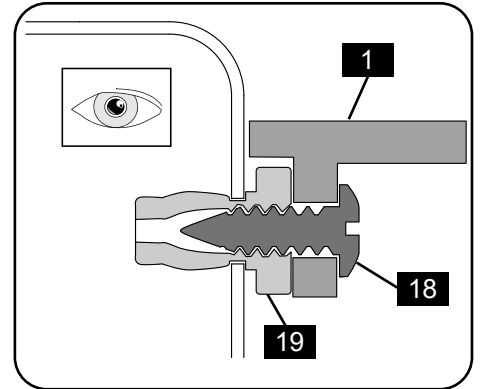
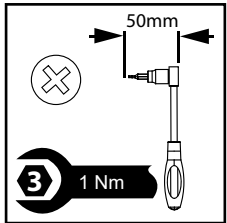

1 1

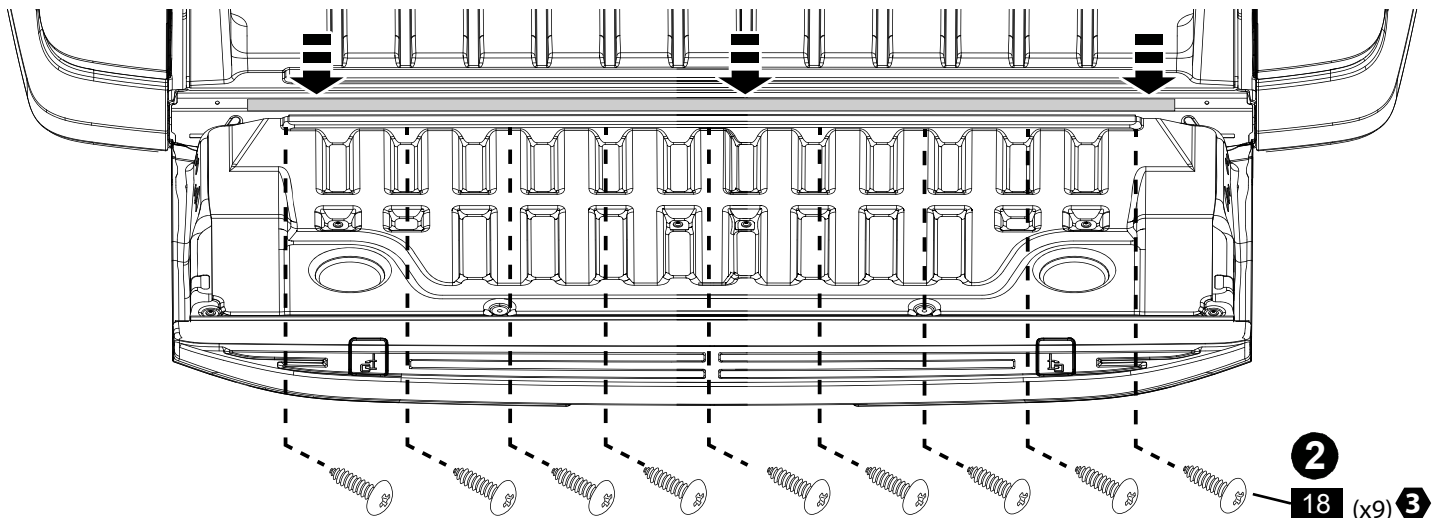
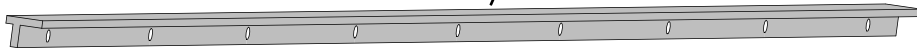

5

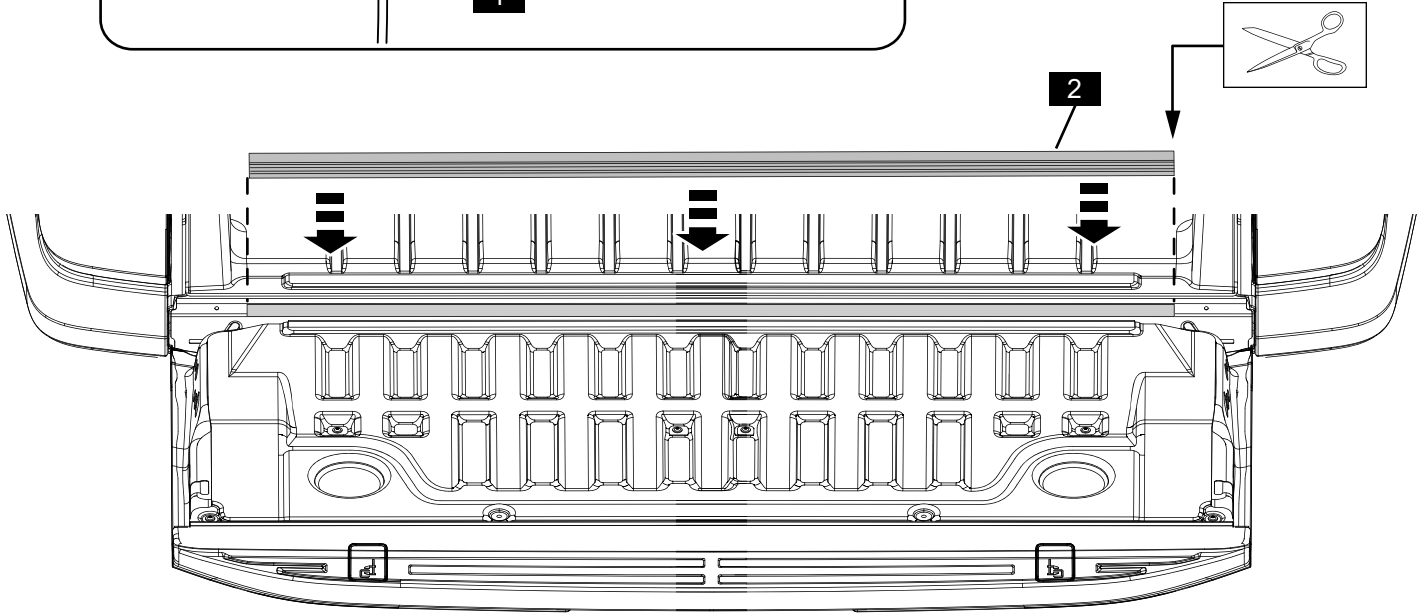
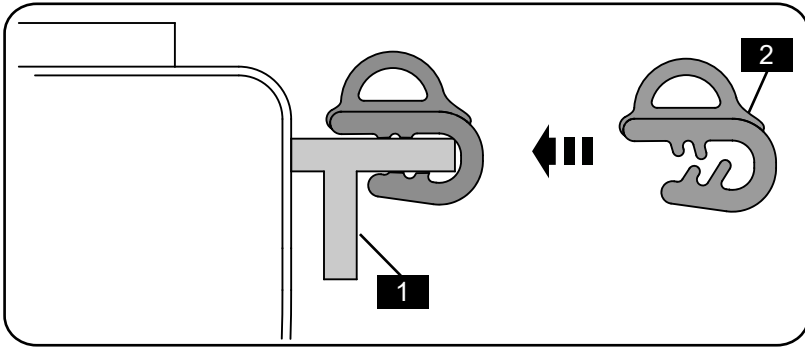

6

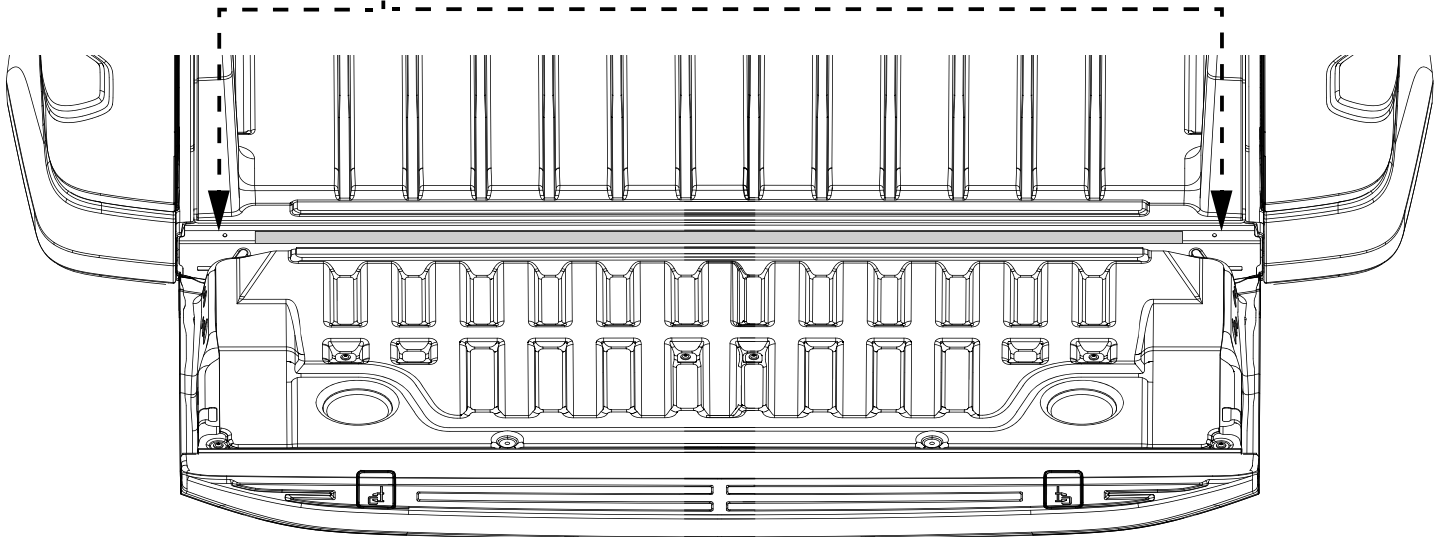
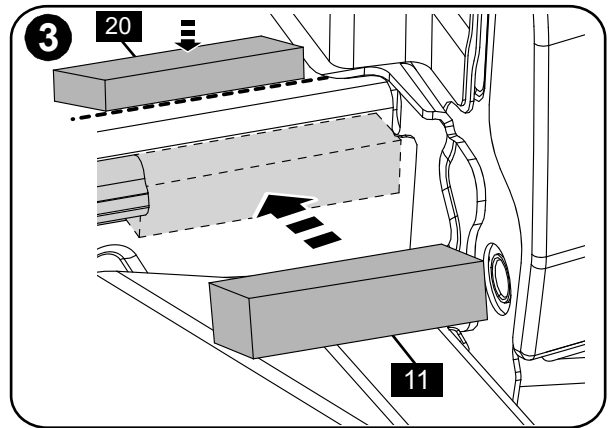
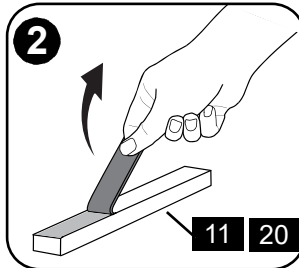
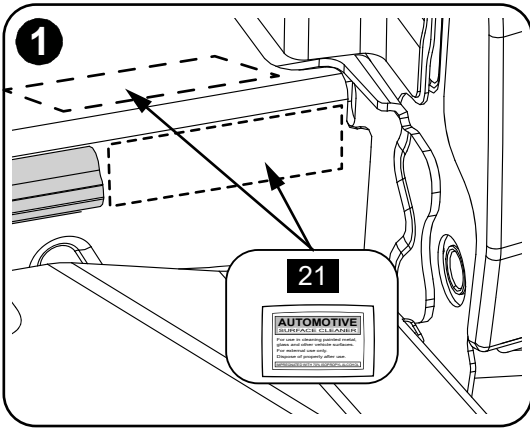
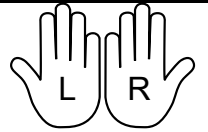

7

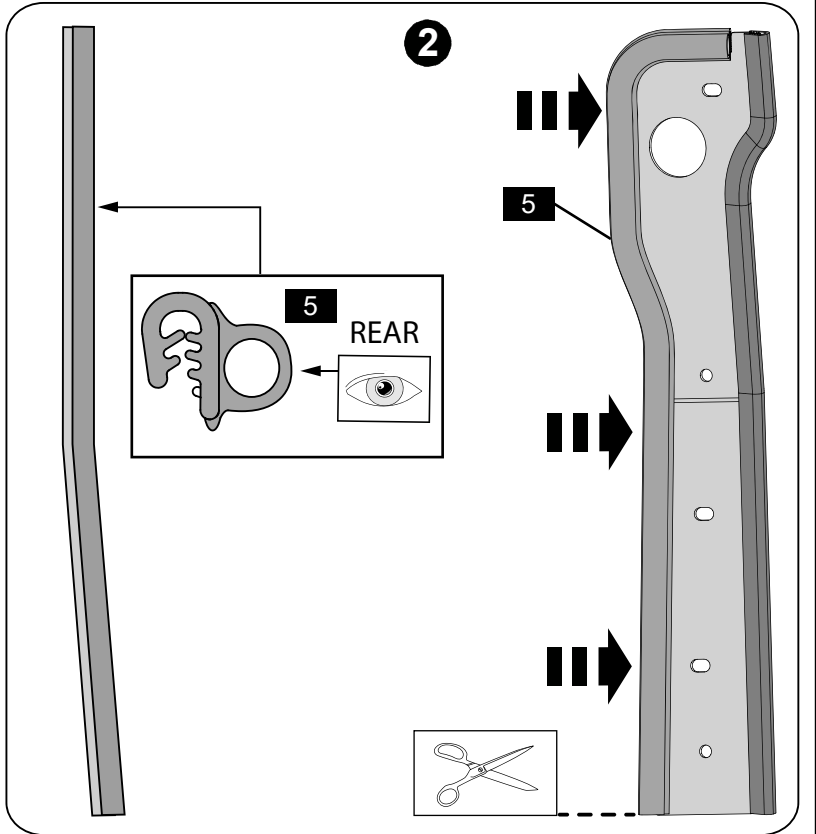
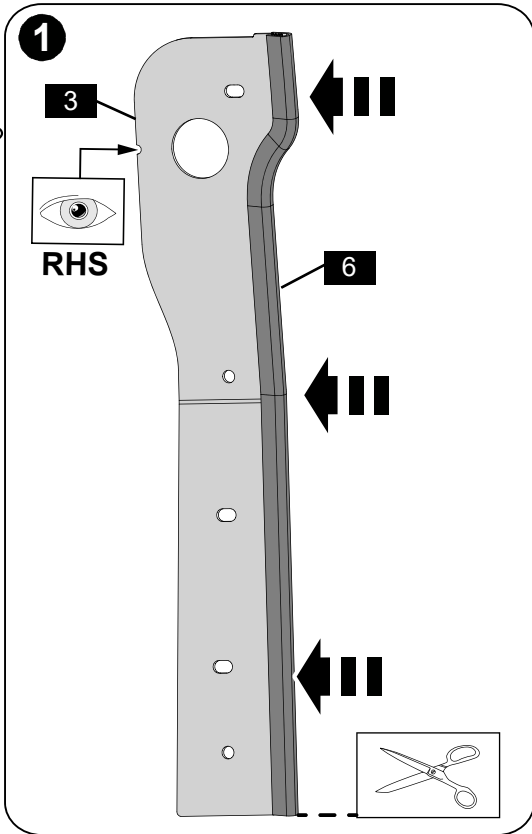

8

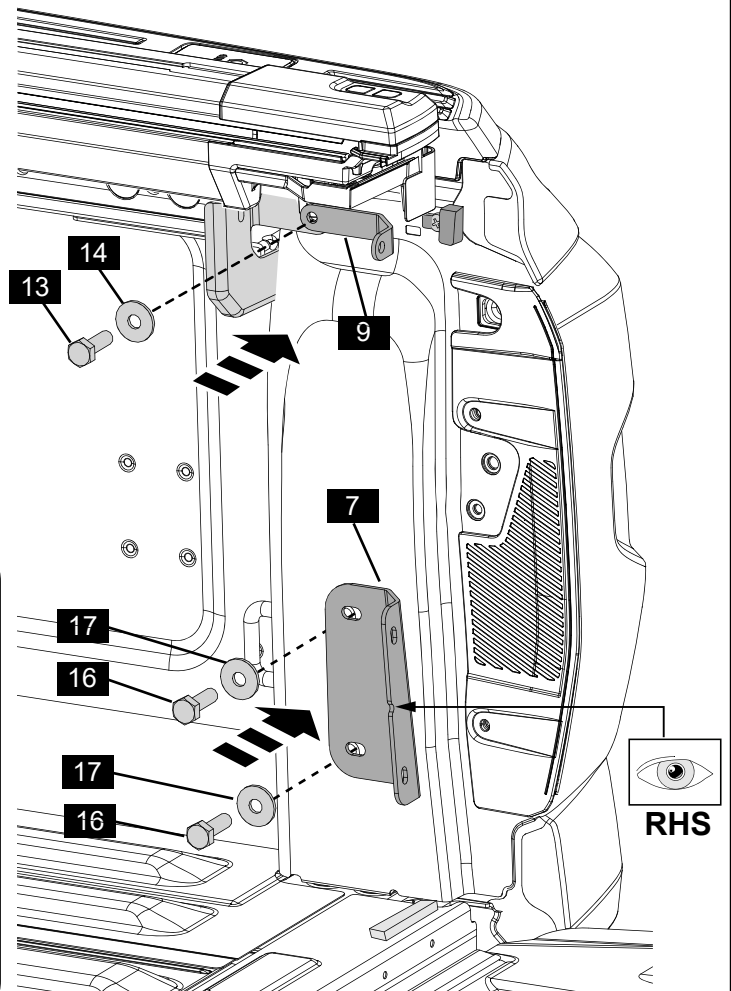
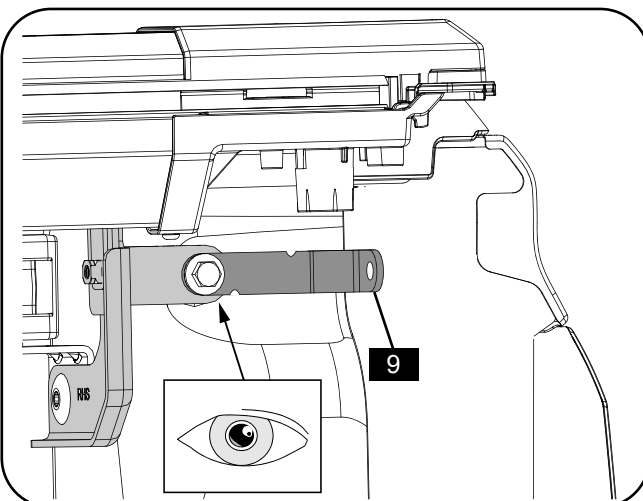
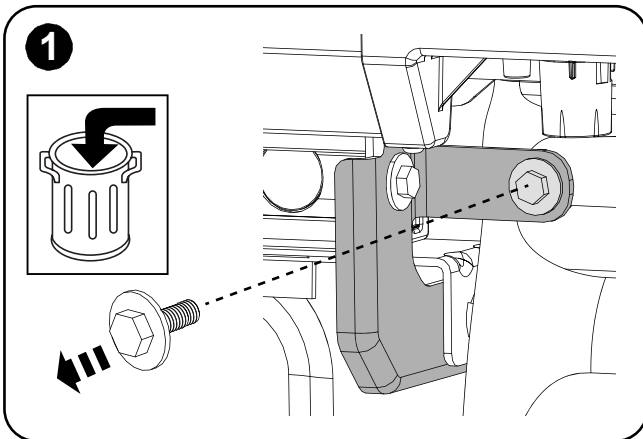
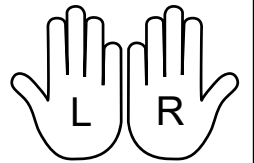
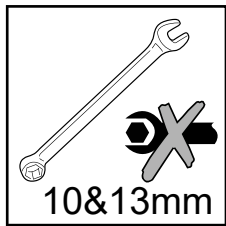

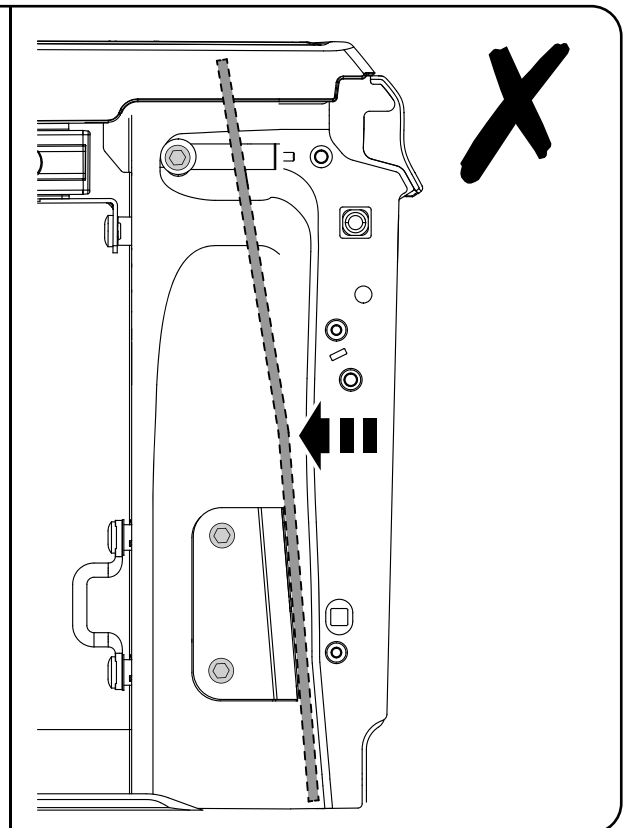
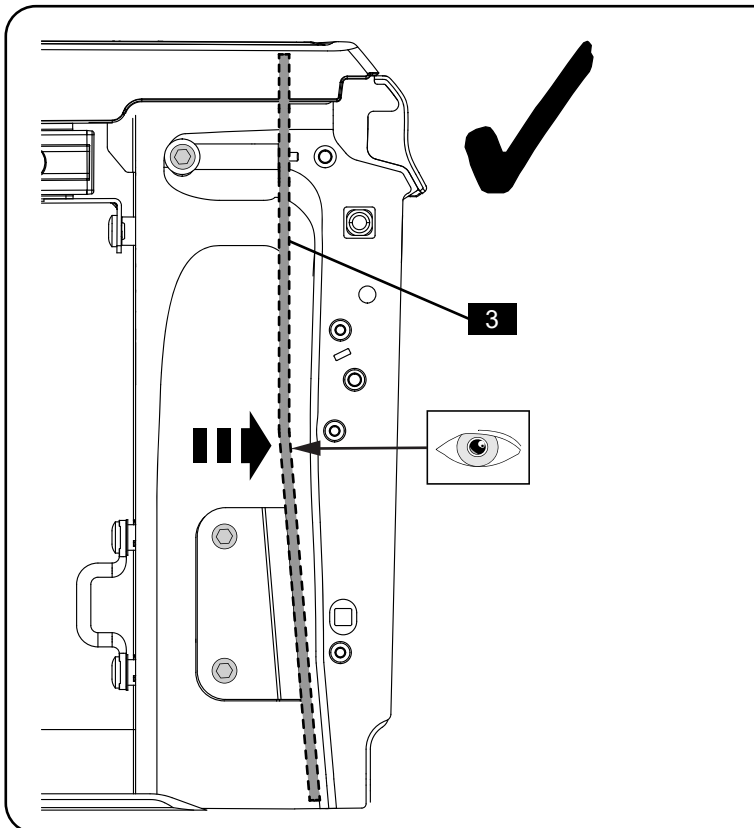
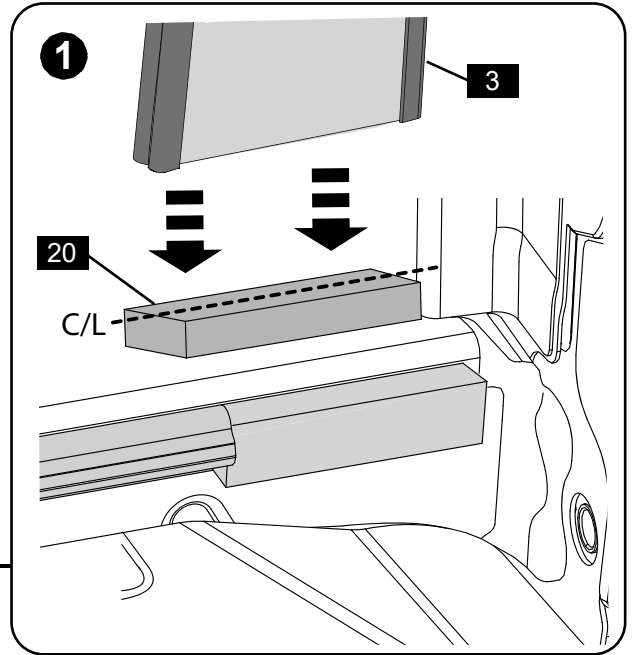
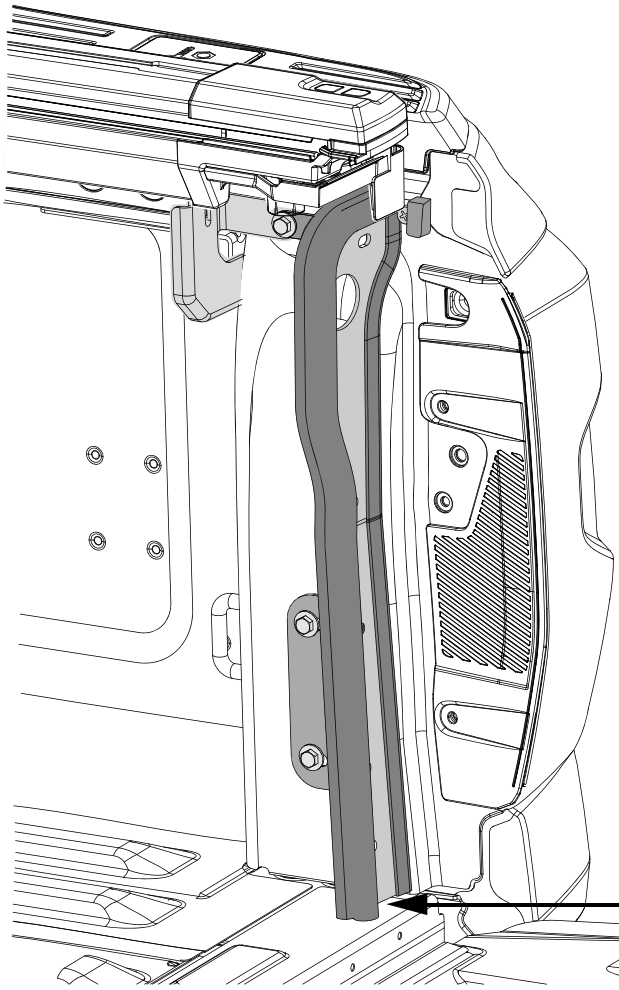

10

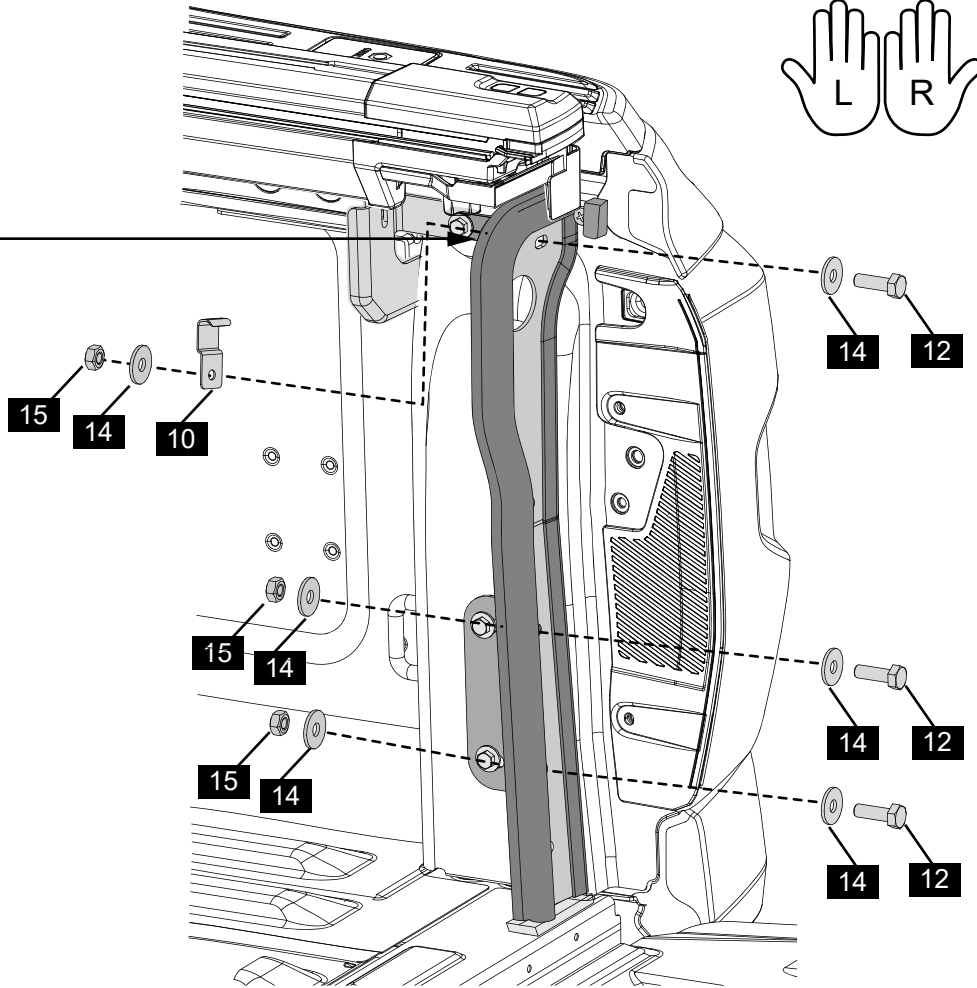
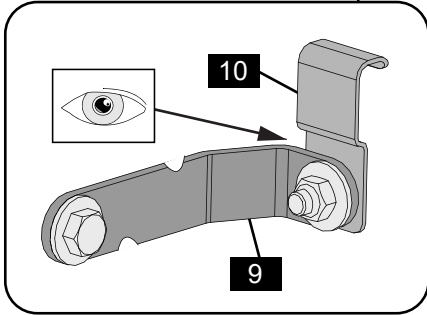
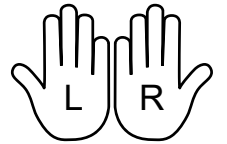
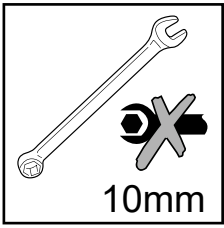

11

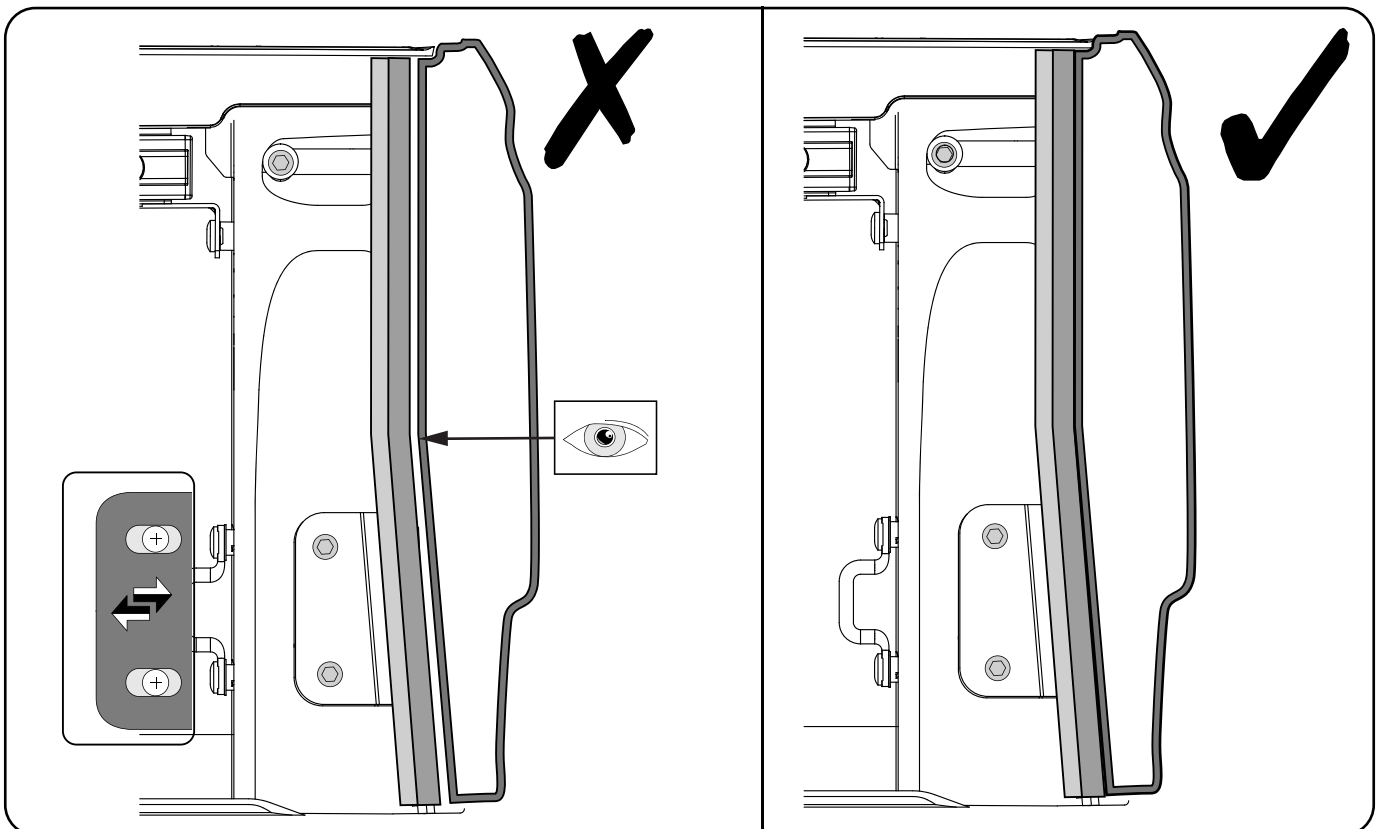

12

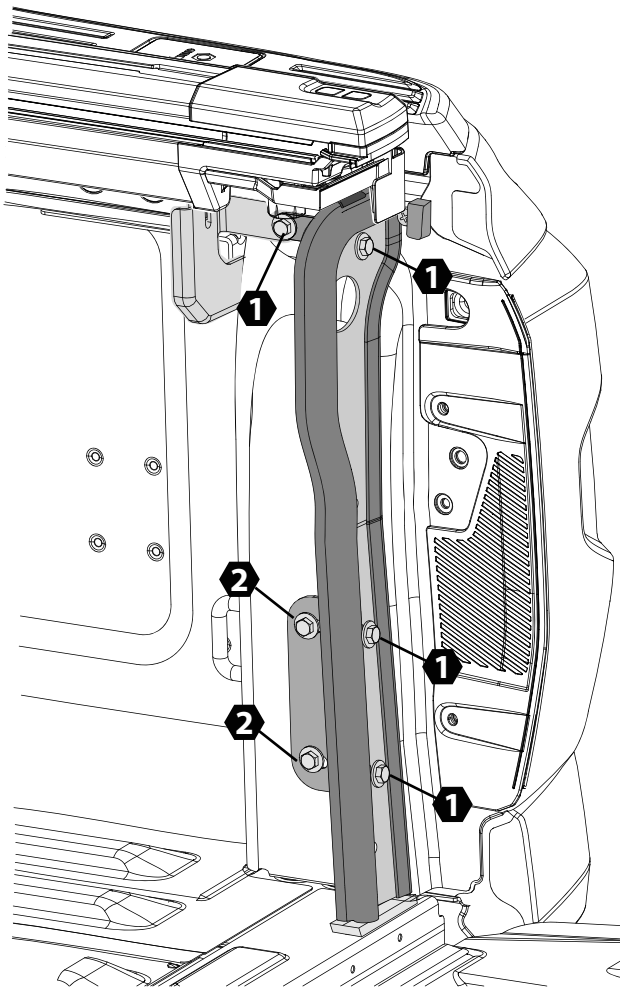
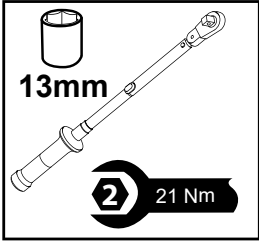
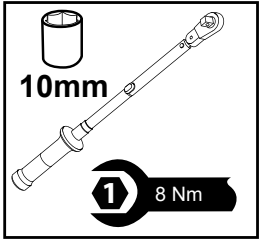
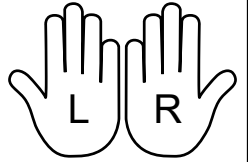

13

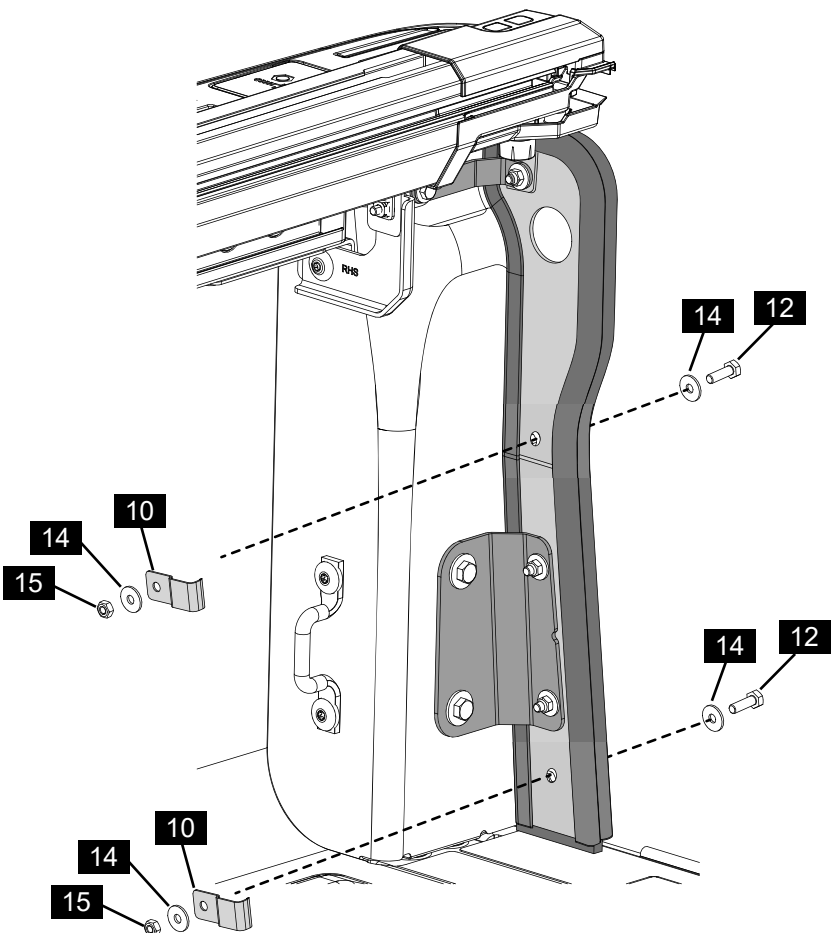
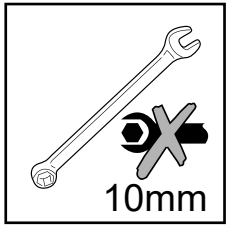
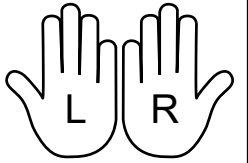

14

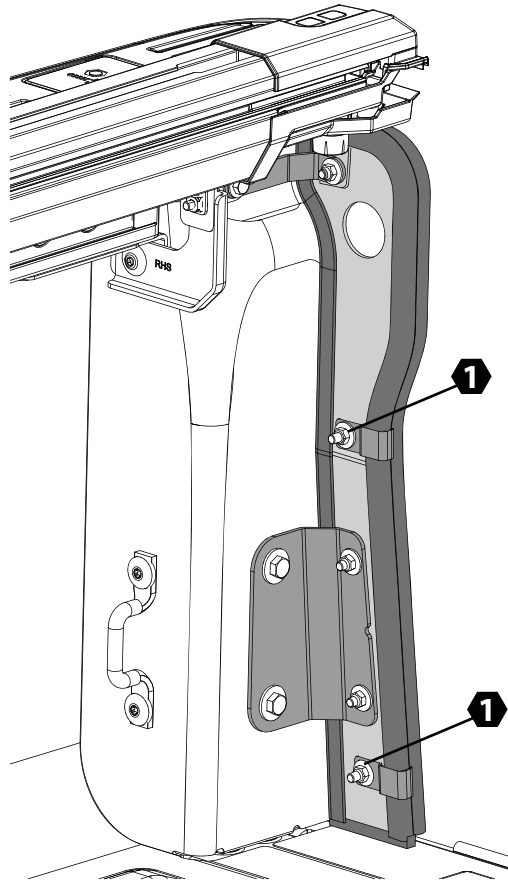
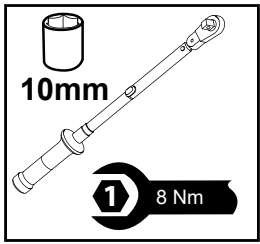
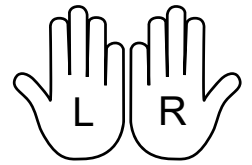

15

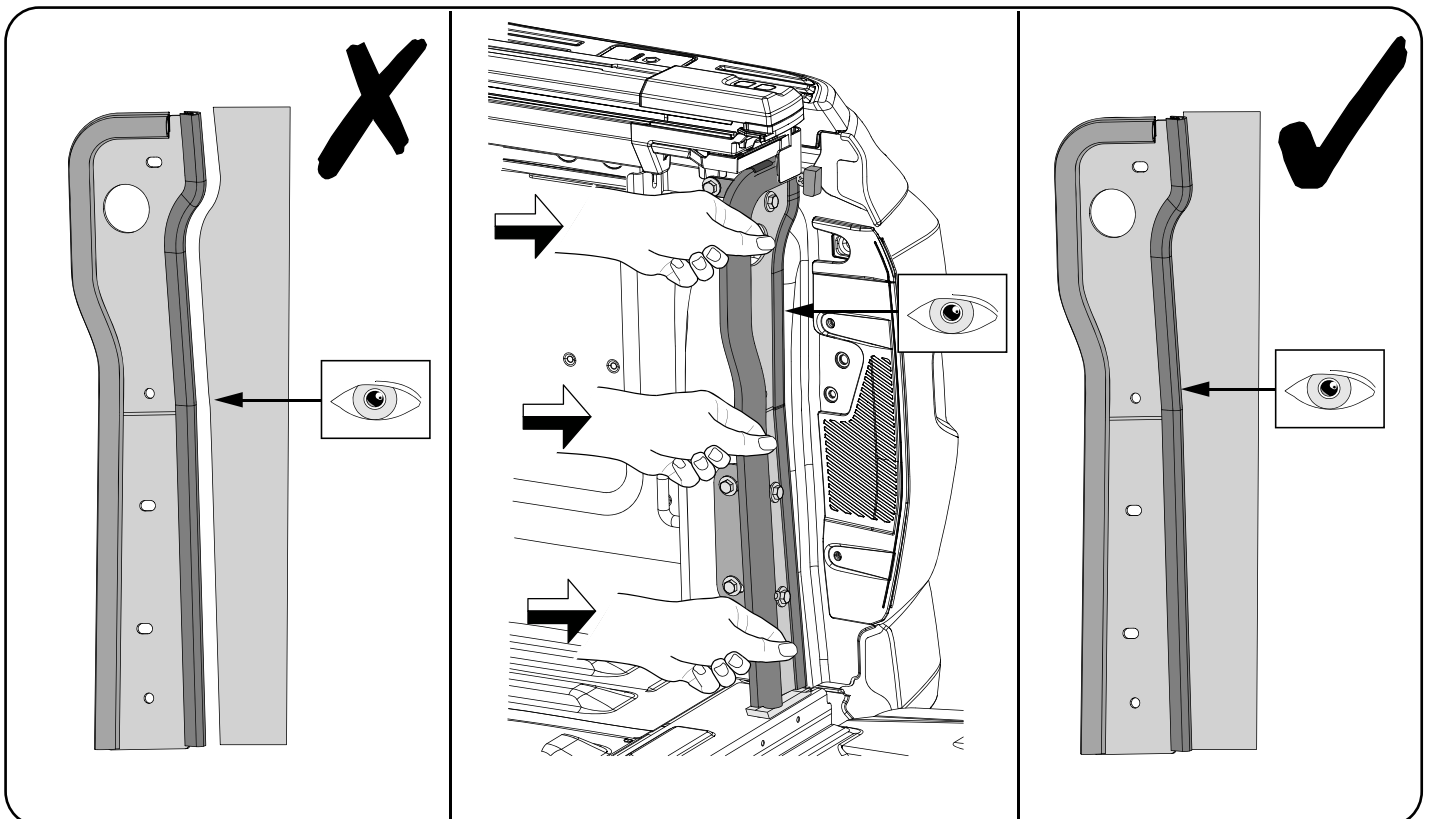
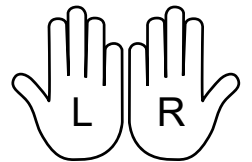

16

