

FRONT FENDER FLARES INSTALLATION INSTRUCTIONS

FF707d
1/4

FORD PX RANGER 2011-

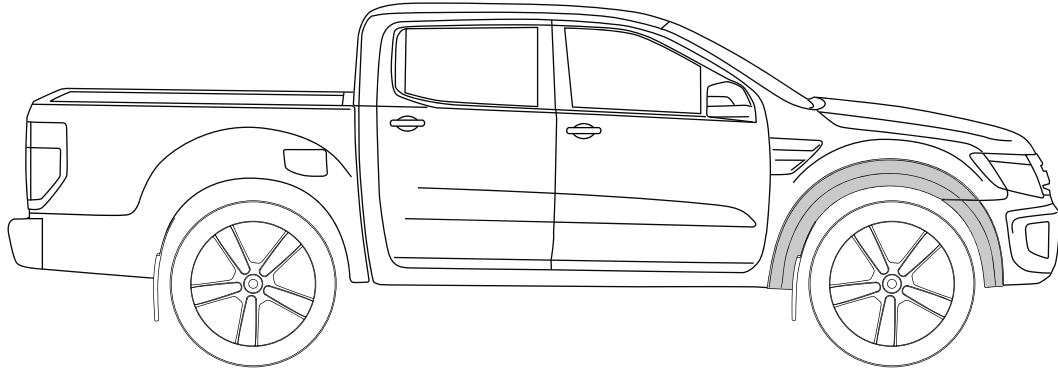

NOTES:

- Ensure that both left and right hand Fender Flares suit the profile of the vehicle. Note the areas where the Fender Flares come in contact with the vehicle.
- Before fitting Fender Flares remove any mouldings, strips or existing flares from the wheel arch. If there is a body side moulding, mark where the moulding is to be cut, alternatively the Fender Flares can be cut to go around the moulding. Be sure to allow enough room for the extrusion.
- Read instructions carefully. This product must be installed exactly as specified in these instructions. Failure to do so may result in improper fit and/or retention.

PAINTING INSTRUCTIONS:

⚠ Warning: Do not fit trim edge extrusion or any of the hardware until paint is completely dry.

- Spot Sand Fender Flares where required prior to painting, recommend 500 grit using an orbital type sander.
- Prior to painting, clean all surfaces to be painted using clean water and a mild detergent, do not use lacquer thinner or any solvent based products. Wipe completely dry.
- Best results will be achieved by wiping the areas to be painted with a tack rag just prior to painting.
- Select a top coat and clear paint that is suitable for ABS (Acrylonitrile-Butadiene-Styrene).
- Automotive paint systems, such as Acrylics or Two Packs, can be applied directly to the components. However, some paints may require a primer. If recommendations on paint specifications are not followed, cracking of the part or degradation to the material may result. In all paint systems, aromatic hydrocarbons and alkalis are best avoided to reduce damage to the material properties.
- If using a paint system which requires baking, do not expose the product to temperatures above 70° C (155° F).
- Allow a minimum of 8 hours after baking before installation on the vehicle.

COMPONENTS LIST

NOTE: FOR SINGLE PART ORDERS, ONLY HALF OF THE FITTING KIT COMPONENTS SUPPLIED

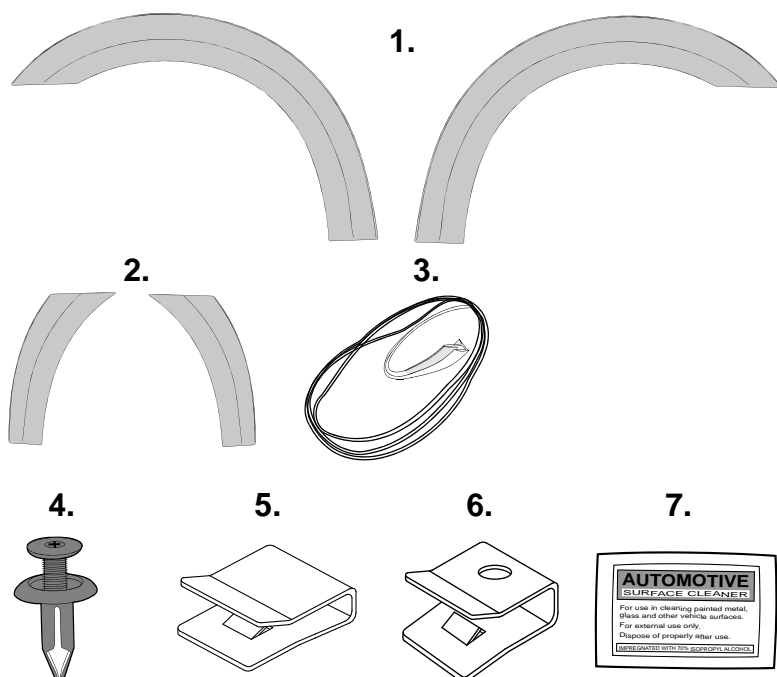

NO.	COMPONENT	QTY
1	Front Fender Flares (RHS & LHS)	2
2	Front Bumper Flares (RHS & LHS)	2
3	Extrusion	5m
4	Scrivet	28
5	Narrow Metal Clip	2
6	Wide Metal Clip	2
7	Alcohol Wipe	2
8	Phillips Head Screw	4
9	J-Nut	4
10	Anti-abrasive Tape	1
11	Installation Instructions	1

FRONT FENDER FLARES INSTALLATION INSTRUCTIONS

FF707d
2/4

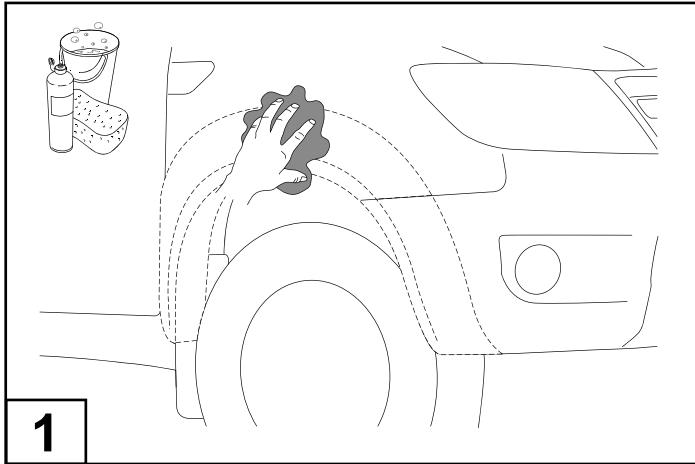

1

Wash the areas of contact on the vehicle and wipe dry both the vehicle and the Fender Flares with a clean cloth. Ensure inside of Fender Flares where extrusion is attached is clean.

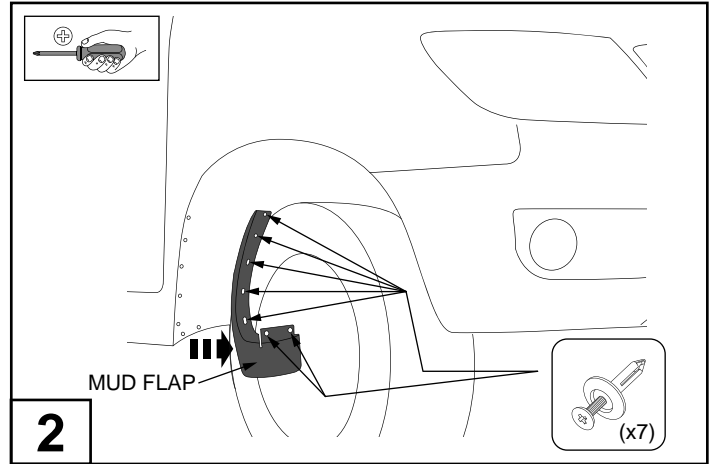

2

Remove the mud flaps by removing and retaining the (7) scrifts from inside the wheel arch as shown. **NOTE:** Replacement scrifts are supplied, if any scrifts are damaged upon removing from the vehicle.

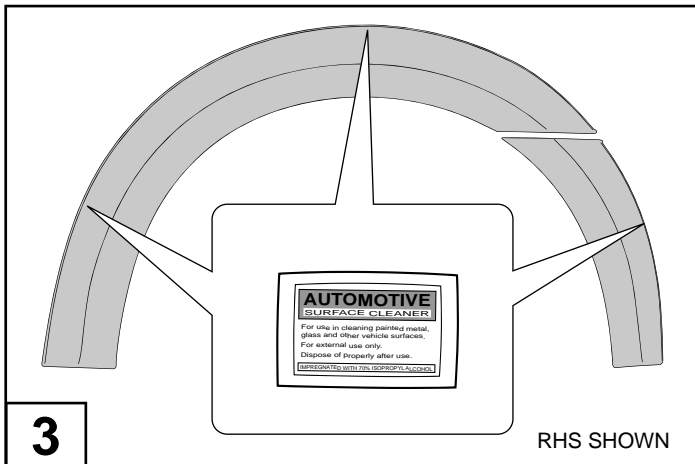

3

RHS SHOWN

Clean the inside edge of each fender flare where the rubber extrusion will adhere.

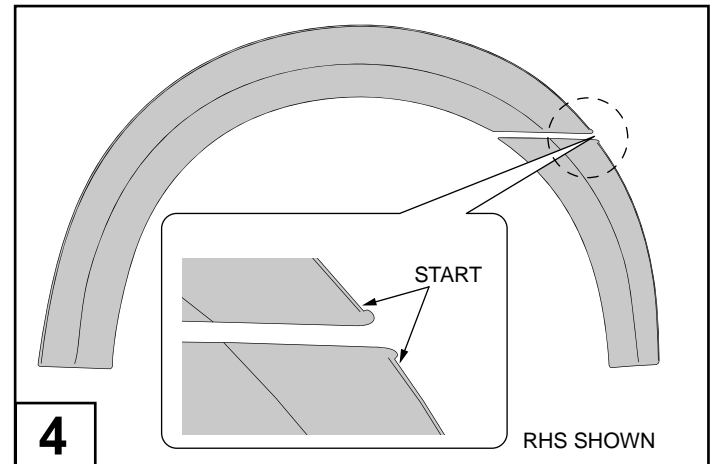

4

RHS SHOWN

Remove approximately 50mm of the protective liner from the extrusion. Fit the extrusion to the Fender Flare along the edge that comes in contact with the vehicle's body panel. **NOTE:** Start applying the extrusion from area shown above.

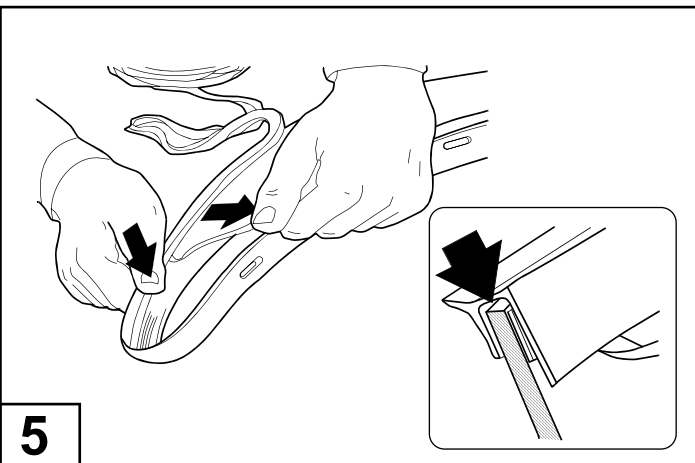

5

Pulling at right angles to the extrusion, remove the liner from the extrusion in small portions and apply thumb pressure to ensure that it adheres to the Fender Flares. Trim any unnecessary extrusion and discard.

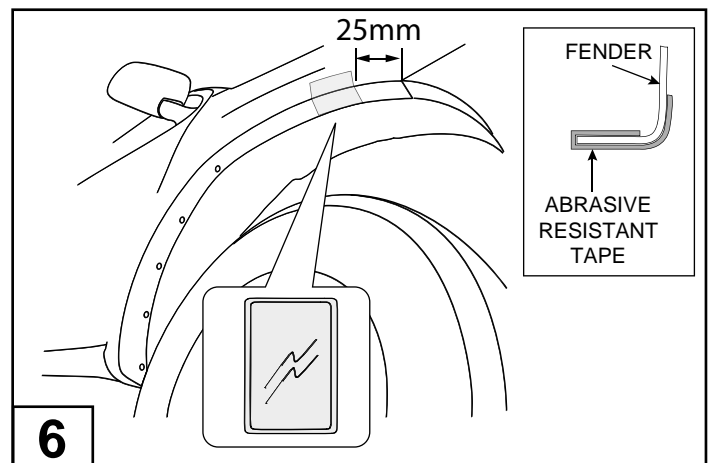

6

Cut in half the anti-abrasive tape and apply to the front fender as marked, 25mm from the front bumper bar. Ensure you wrap the abrasive tape strip down around the lower edge of the fender onto the inside.

FRONT FENDER FLARES INSTALLATION INSTRUCTIONS

FF707d
3/4

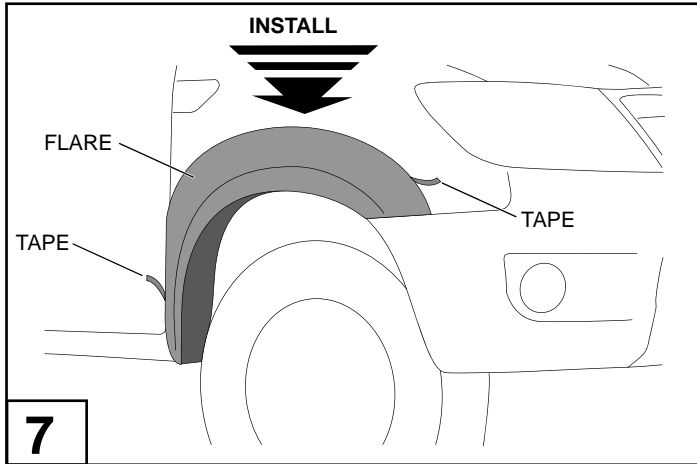

7

Peel back red tape liner, about 50mm from each corner of the adhesive tape on the back of the fender flare. Fit the flare to the vehicle as shown.

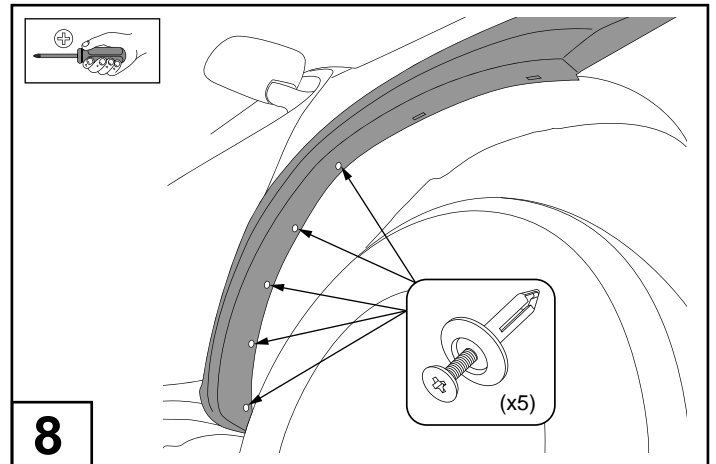

8

Install (5) wheel arch scrivenets onto the flare as shown. While pressing and holding the flare in position of best fit.

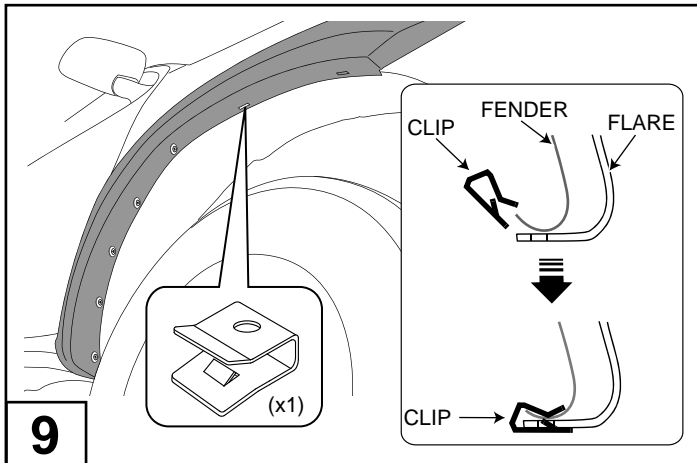

9

Install the wide clip at an angle, by pushing it on to the fender lip and then rotate downwards, as shown.

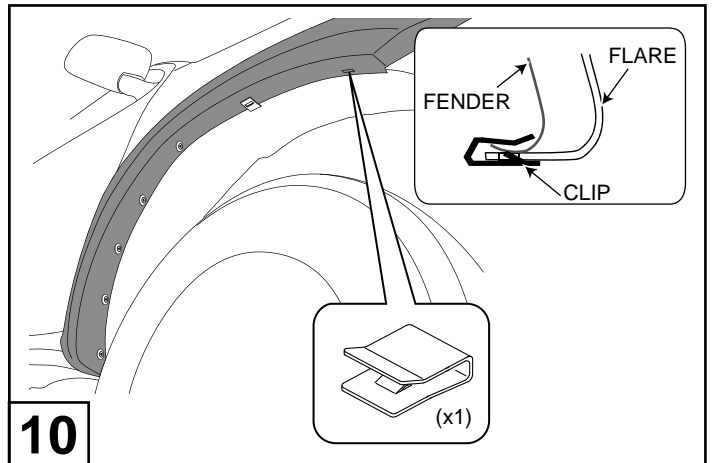

10

Install the narrow clip next, as shown.

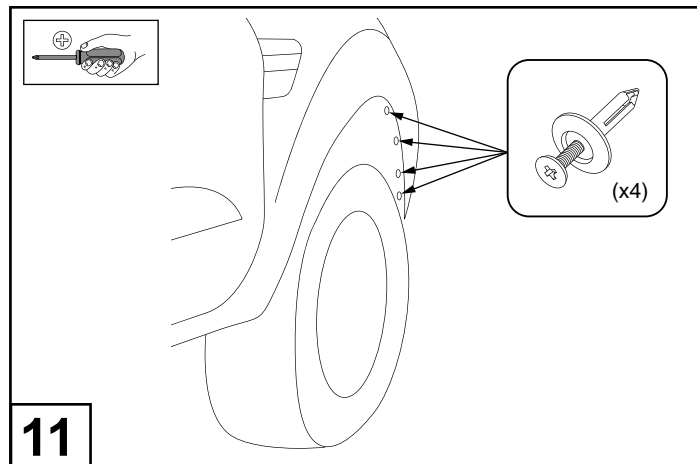

11

Remove all (4) scrivenets from the wheel arch on front bumper.

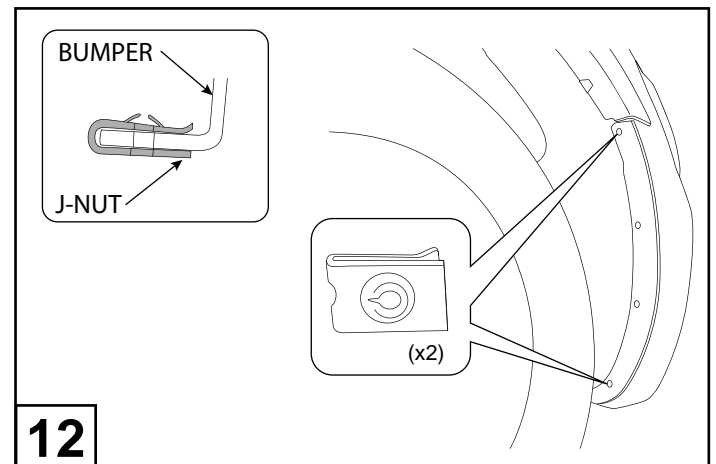

12

Hold the splash guard inwards and push the supplied (2) J-nuts onto the front bumper in the top and bottom hole position as shown.

FRONT FENDER FLARES INSTALLATION INSTRUCTIONS

FF707d
4/4

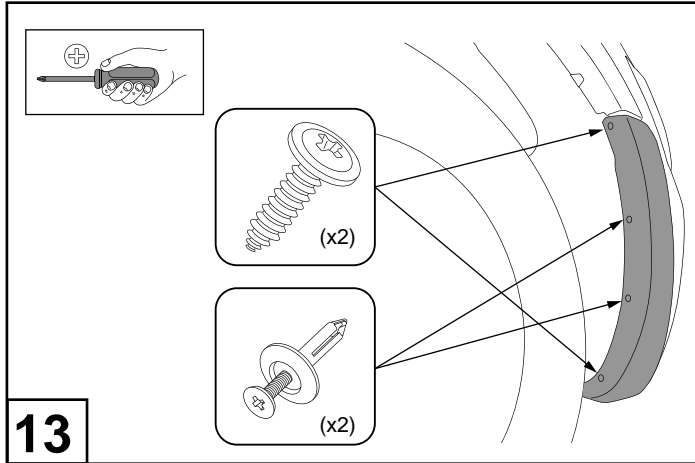

13

Secure the fender flare to the bumper with (2) Phillips head screws and (2) scrivenets as shown.

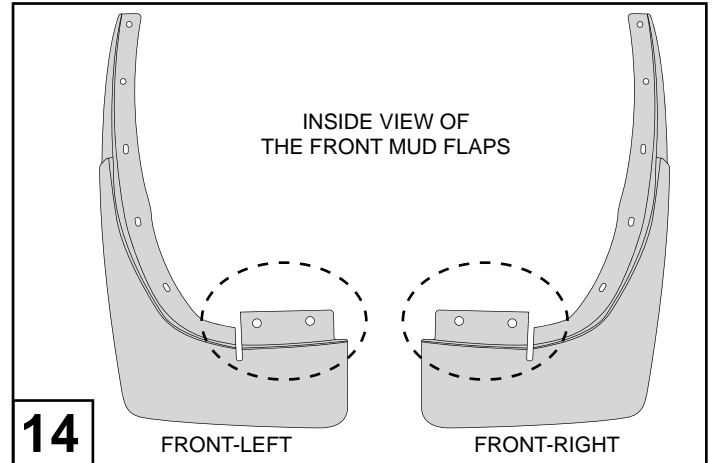

14

Prepare the Front Mud Flaps by cleaning them & covering the marked areas with masking tape.

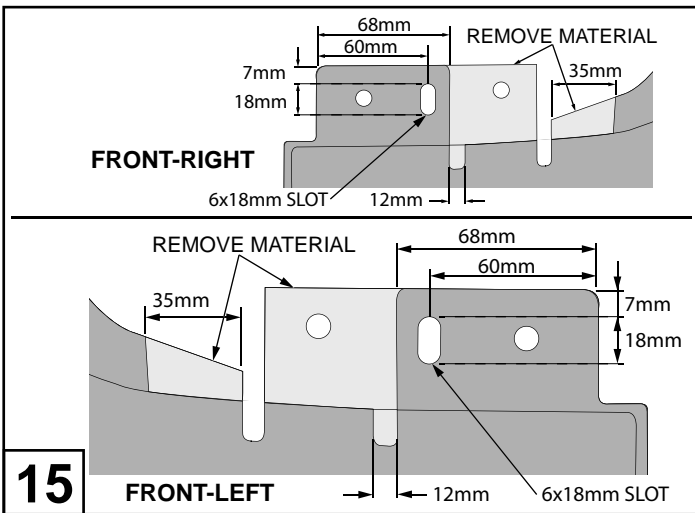

15

Measure & mark slot position & Mud Flap area to be removed, as shown. Using tin snips remove the light grey area. Cut 6x18mm slot using a die grinder. Remove all the masking tape.

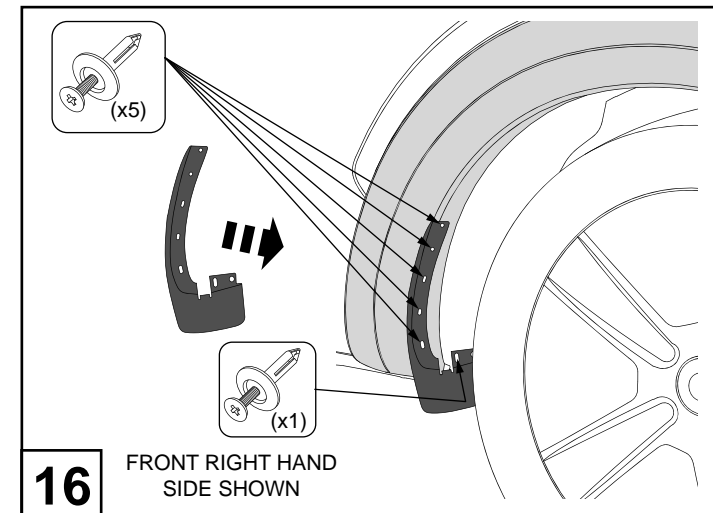

16

Fit the Mud Flaps to the Fender Flare and secure each Mud Flap with six (6) Scrivenets supplied as shown.

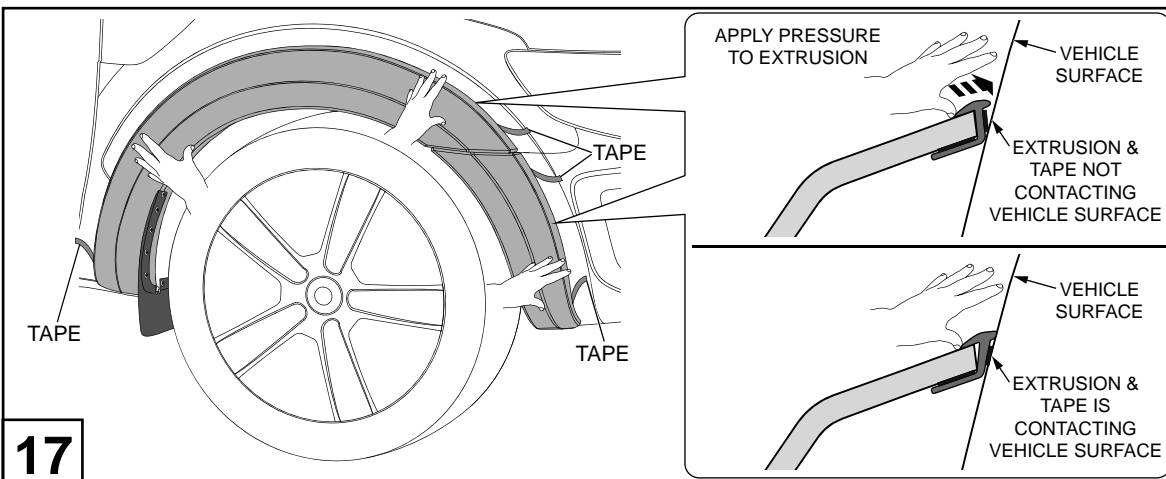

17

Ensure that flares are aligned. Remove the tape liner. Using your thumb and/or fingers apply firm pressure on the extrusion to ensure the extrusion and the tape is contacting the vehicle surface around the full perimeter of the flares.