

# FENDER FLARES INSTALLATION INSTRUCTIONS

## FORD PX2 RANGER 2015-

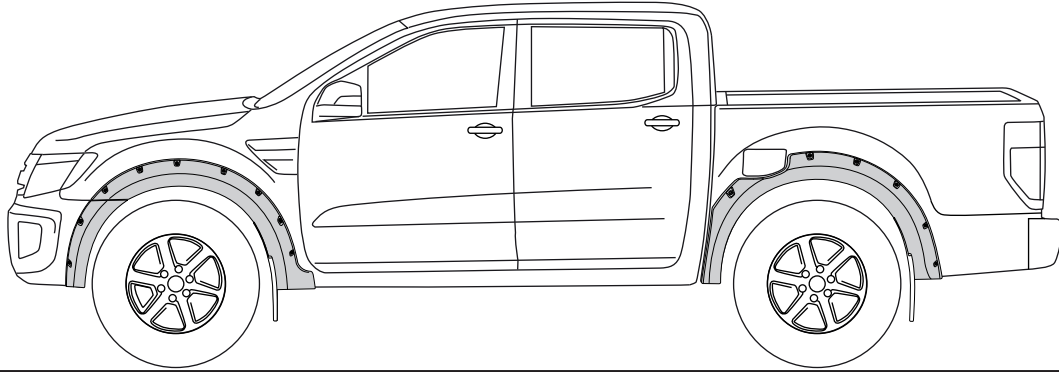

**NOTES:**

- Ensure that both left and right hand Fender Flares suit the profile of the vehicle. Note the areas where the Fender Flares come in contact with the vehicle.
- Before fitting Fender Flares remove any mouldings, strips or existing flares from the wheel arch. If there is a body side moulding, mark where the moulding is to be cut, alternatively the Fender Flares can be cut to go around the moulding. Be sure to allow enough room for the extrusion.
- Read instructions carefully. This product must be installed exactly as specified in these instructions. Failure to do so may result in improper fit and/or retention.

**TOOLS REQUIRED:**

- Short Phillips head Screwdriver
- Flat head Screwdriver
- Drill & 8mm & 10.5mm Drill Bit
- Steel Ruler
- Tin Snips
- 7mm,8mm & 10mm Socket or Spanner
- Masking Tape
- Mild Soapy Water & Clean Cloths
- Felt Tip Marker
- Utility Knife

### COMPONENTS LIST

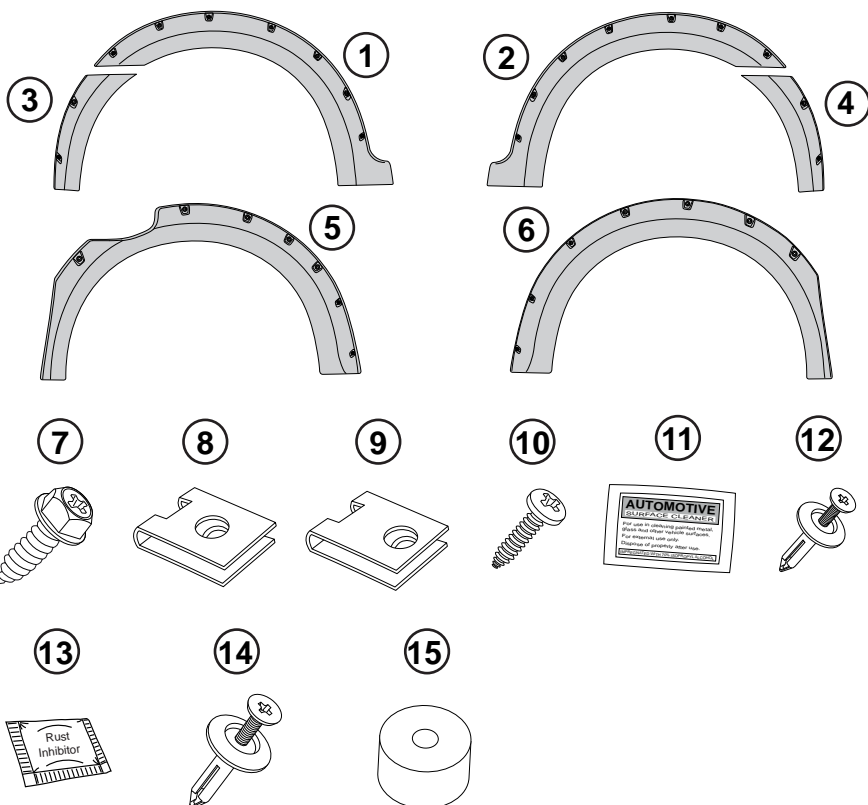

NO.	COMPONENT	QTY
1	Front LHS Fender Flare	1
2	Front RHS Fender Flare	1
3	Front LHS Bumper Flare	1
4	Front RHS Bumper Flare	1
5	Rear LHS Fender Flare	1
6	Rear RHS Fender Flare	1
7	Screw 25mm	20
8	Speed Clip 8.5mm hole centre	12
9	Speed Clip 11mm hole centre	4
10	Phillips Head Screw	2
11	Alcohol Wipe	4
12	6mm Plastic Scrivet	16
13	Rust Inhibitor	1
14	10mm Plastic Scrivet	4
15	5mm Spacer	4

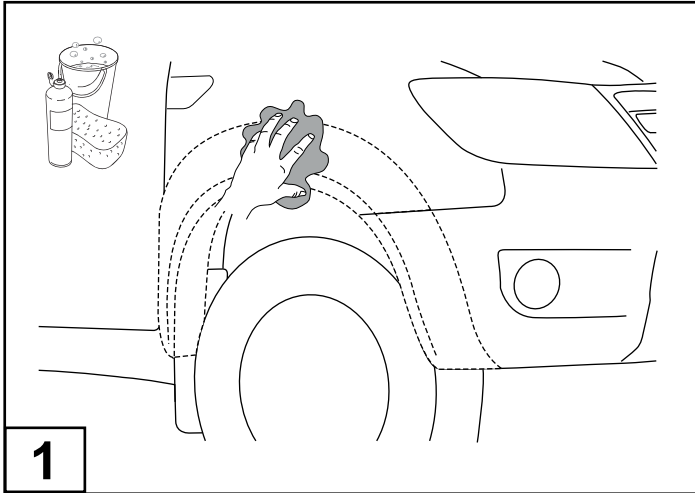
**1**

Wash the areas of contact on the vehicle and wipe dry. Wipe the fender where the flare will contact, using provided Alcohol wipes.

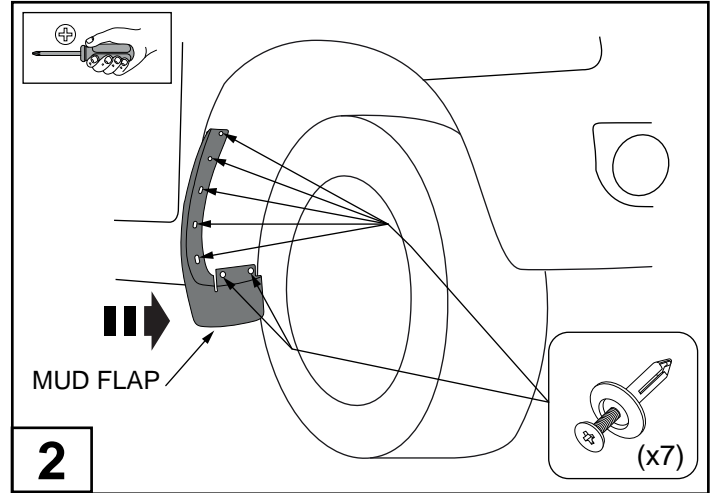
**2**

Remove the mud flap by removing the (7) screws from inside the wheel arch as shown.

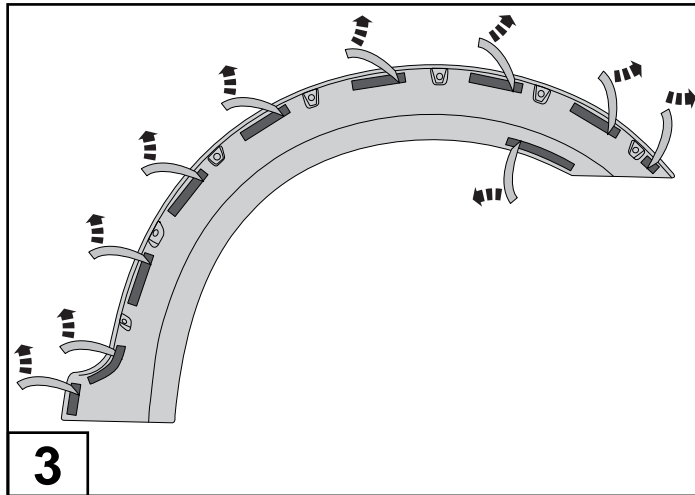
**3**

On the inside of the fender flare remove approximately 25mm of the protective liner from the double sided tape locations. Fold the liner over and secure with masking tape to the outside of the bumper flare.

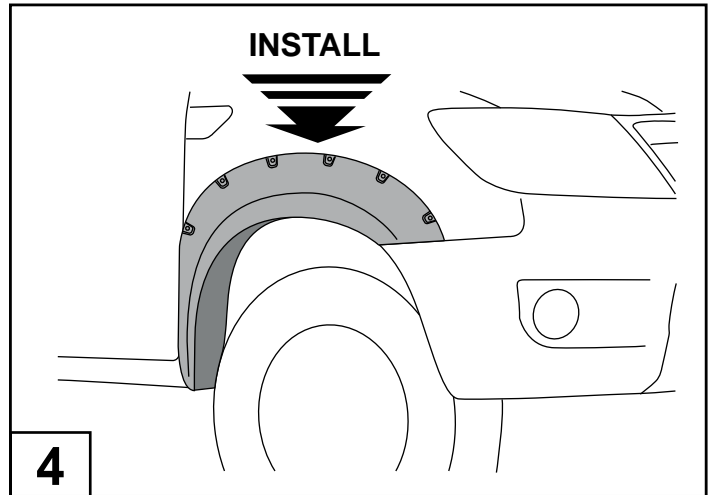
**4**

Fit the fender flare to the vehicle in the uppermost vertical position, before final fixings and tape application is completed as shown.

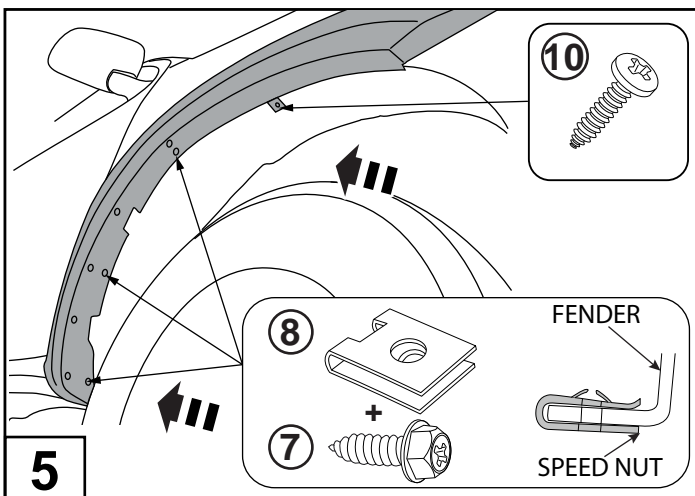
**5**

Hold the splash guard inwards and push the supplied (3x) 8.5 Speed Nuts onto the front guard into the 3 hole positions as shown. Fold the plastic Tab inwards over the fender and secure with one Phillips head screw.

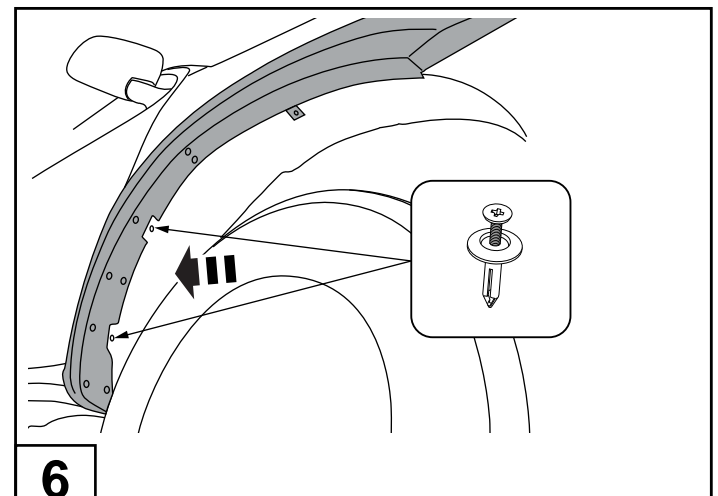
**6**

Reattach the wheel arch liner with two factory screws.

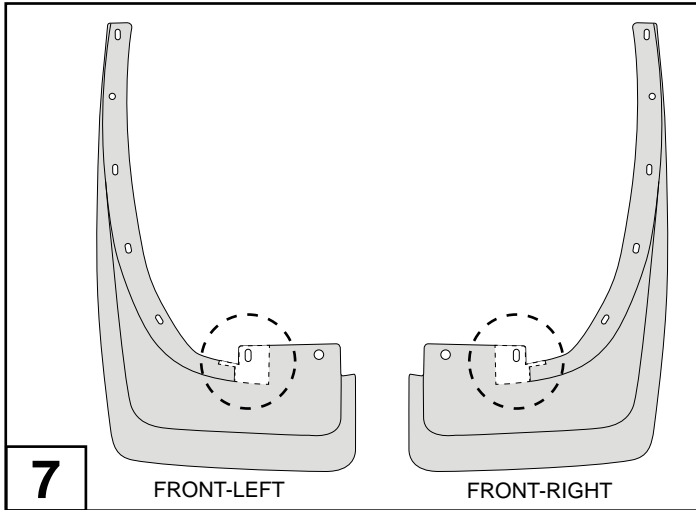

**7**

FRONT-LEFT

FRONT-RIGHT

Prepare the Front Mud Flaps by cleaning them & covering the marked areas with masking tape.

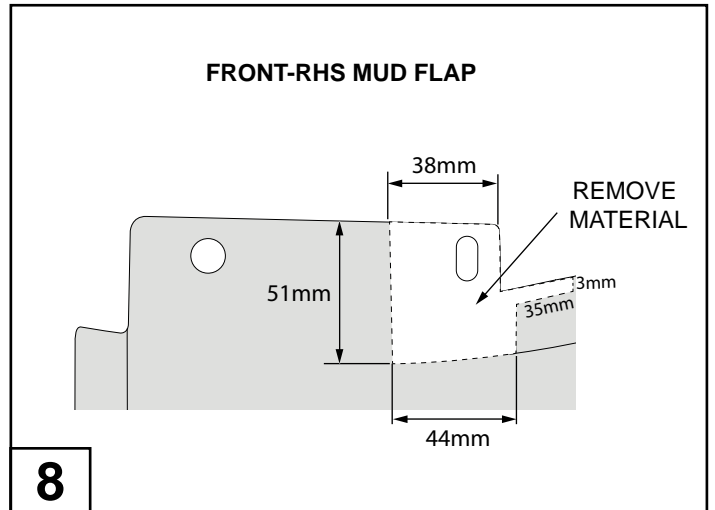

**8**

FRONT-RHS MUD FLAP

REMOVE MATERIAL

Measure and mark Mud Flap area to be removed, as shown. Using tin snips remove the white area. Repeat for the LHS Mud Flap. Remove all the masking tape.

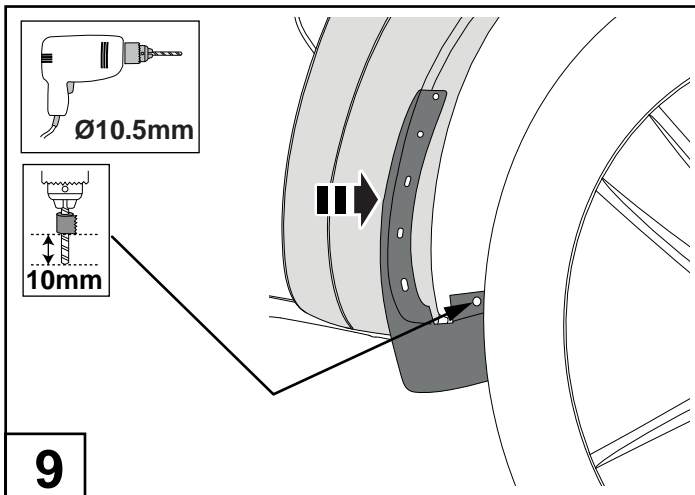

**9**

Fit the Mud Flap to the Fender Flare aligning with all the holes. Mark and drill a 10.5mm hole in the liner for the bottom scrivet as shown.

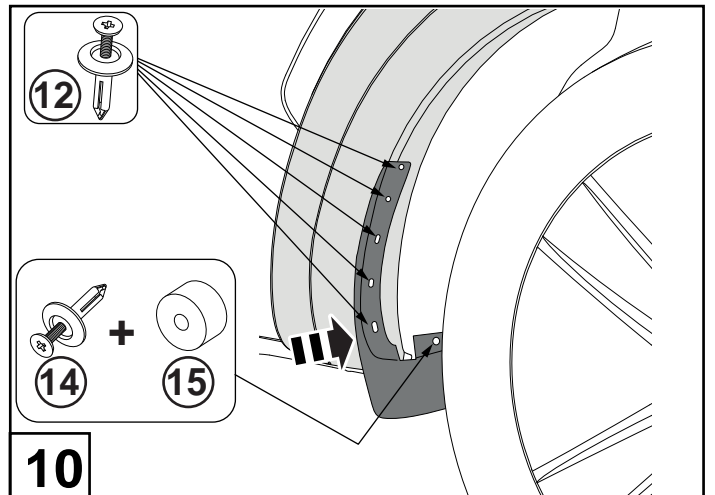

**10**

Fit the Mud Flaps to the Fender Flare and secure with (5) 6mm Plastic Scrivets. Secure the bottom part of the mud flap with one 10mm Plastic Scrivet and place the 5mm spacer behind the Mud Flap.

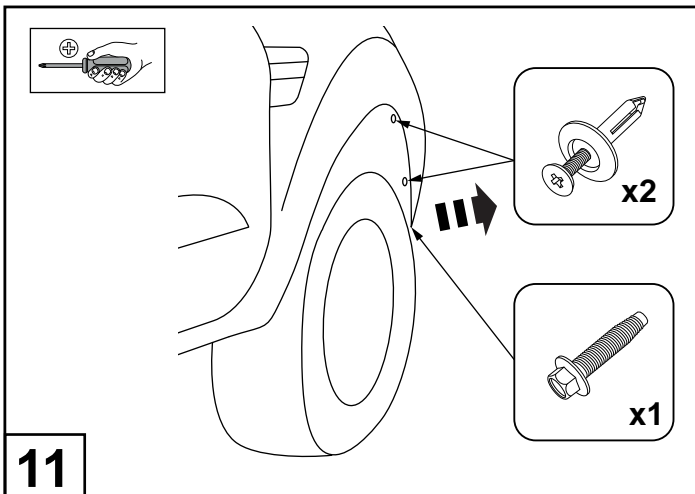

**11**

Remove and retain (2) scrivets from the wheel arch on the front bumper. Remove and retain the Hex head screw located under the bumper.

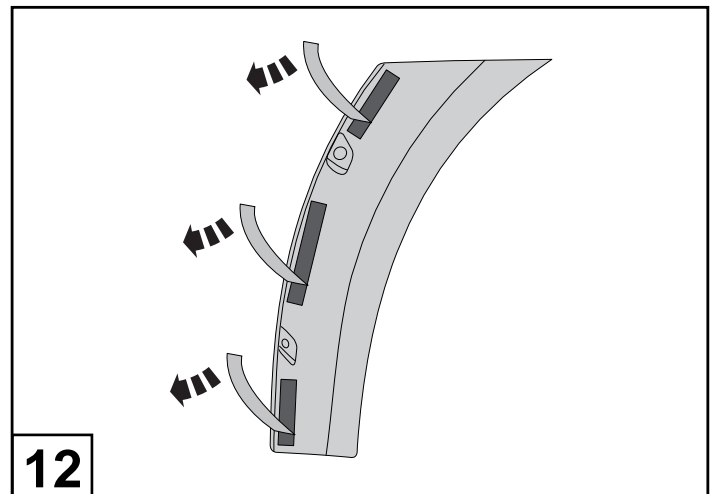

**12**

On the inside of the bumper flare remove approximately 25mm of the protective liner from the double sided tape locations. Fold the liner over and secure with masking tape to the outside of the fender flare.

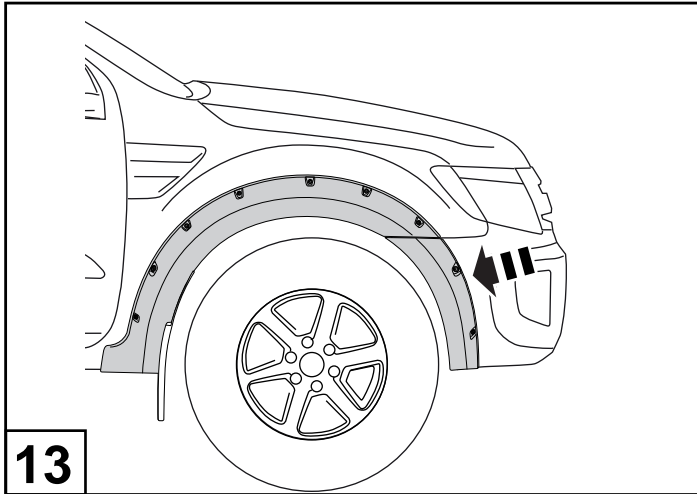
**13**

Fit the bumper flare to the vehicle as shown.

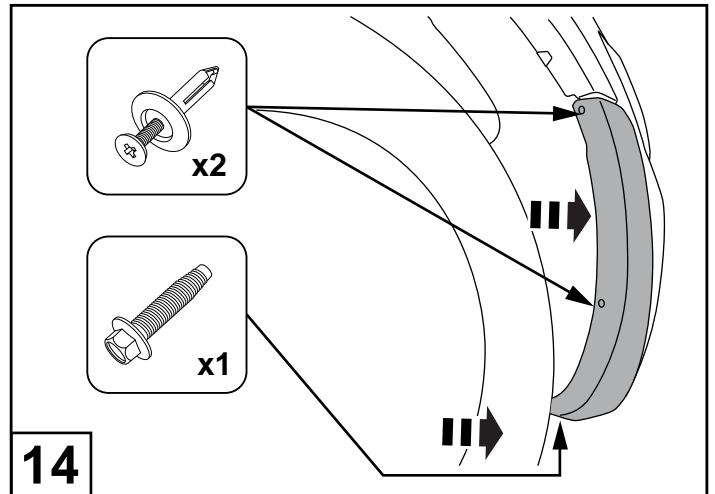
**14**

Secure the flare using previously removed scrivenets and screw as shown.

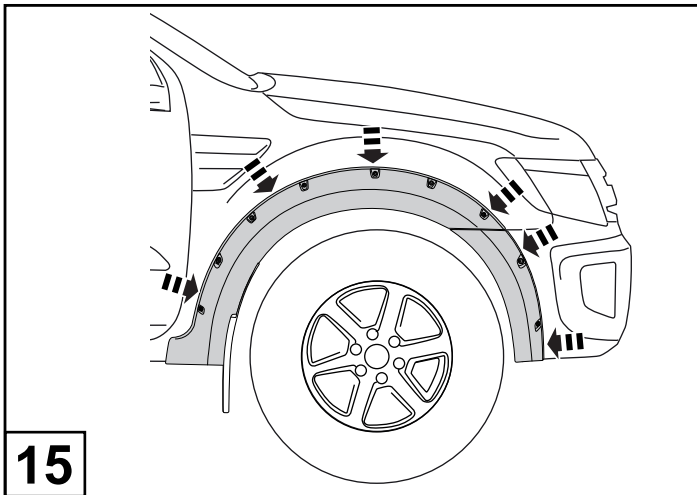
**15**

Ensure that flares are aligned. Remove the tape liner. Apply firm pressure on the flare to ensure the tape is contacting the vehicle surface around the full perimeter of the flares.

**FOR THE LHS FRONT FENDER FLARE  
INSTALLATION REPEAT STEPS 1 TO 15**

**CONTINUE WITH STEP 16 FOR THE REAR  
LHS FENDER FLARE INSTALLATION**

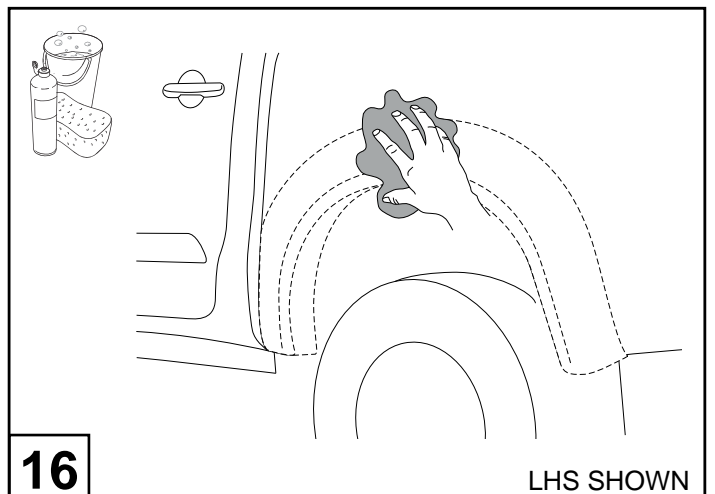
**16**

LHS SHOWN

Wash the areas of contact on the vehicle and wipe dry. Wipe the fender where the flare will contact, using provided Alcohol wipes.

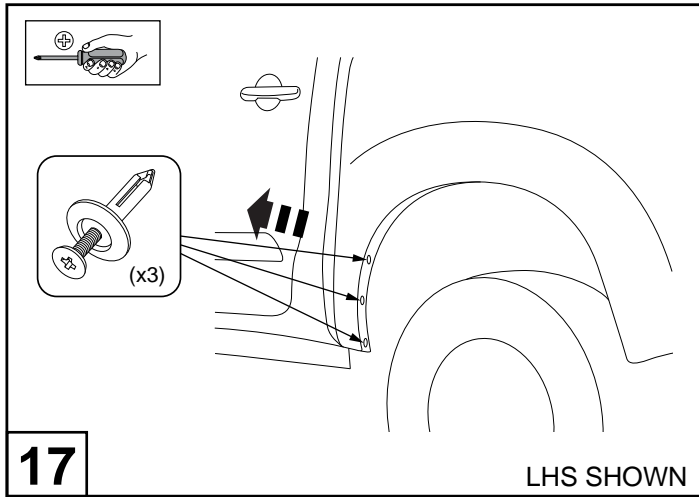

**17**

LHS SHOWN

Remove the (3) screws from inside the rear wheel arch as shown.

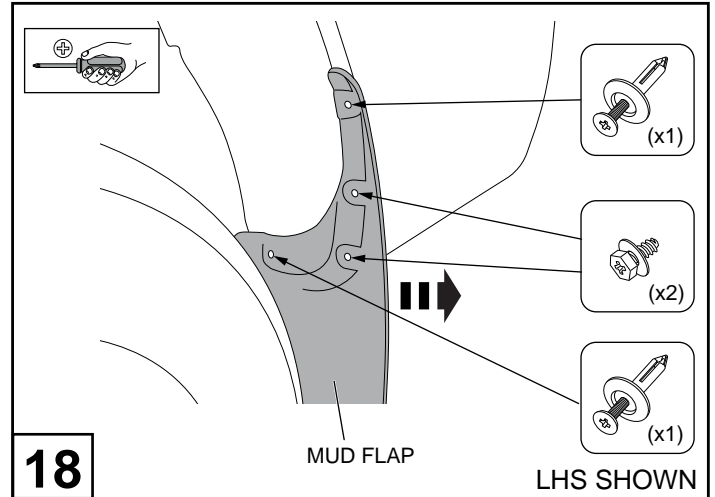

**18**

LHS SHOWN

Remove the rear mud flaps by removing and retaining the (2) screws and (2) screws from inside the wheel arch as shown.

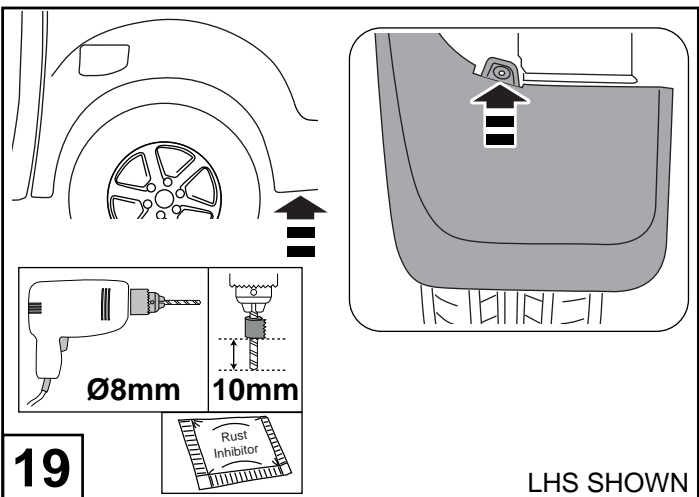

**19**

LHS SHOWN

Carefully drill through centre of rivet holding the liner behind the rear mud flap, with a Ø8mm drill bit & and 10mm drill stop as shown. Carefully remove the remainder of the rivet using needle nose pliers. Apply rust inhibitor to the holes.

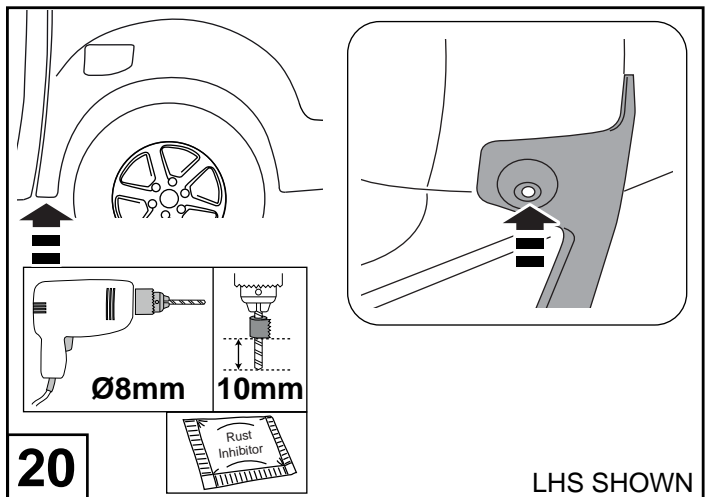

**20**

LHS SHOWN

Carefully drill through centre of rivet holding the liner with a Ø8mm drill bit & and 10mm drill stop as shown. Carefully remove the remainder of the rivet using needle nose pliers. Apply rust inhibitor to the holes.

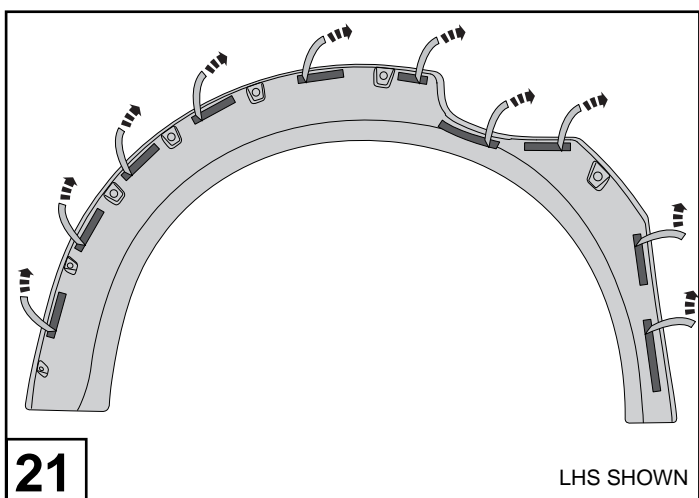

**21**

LHS SHOWN

On the inside of the fender flare remove approximately 25mm of the protective liner from the double sided tape locations. Fold the liner over and secure with masking tape to the outside of the bumper flare.

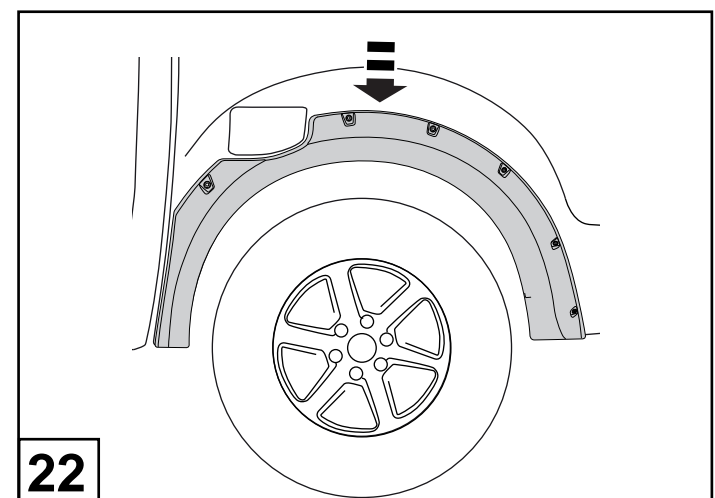

**22**

Fit the fender flare to the vehicle in the uppermost vertical position, before final fixings and tape application is completed as shown.

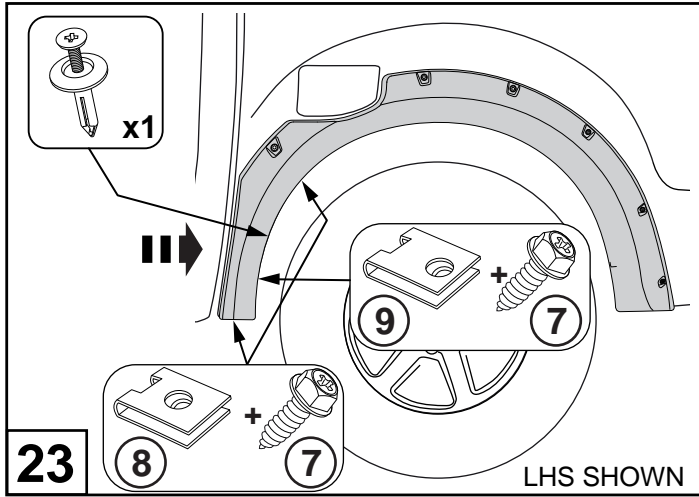

**23** Attach the front part of the rear fender flare with (3) Hex head screws and Speed nuts as per front fender process. Reuse one factory plastic scrivet as shown.

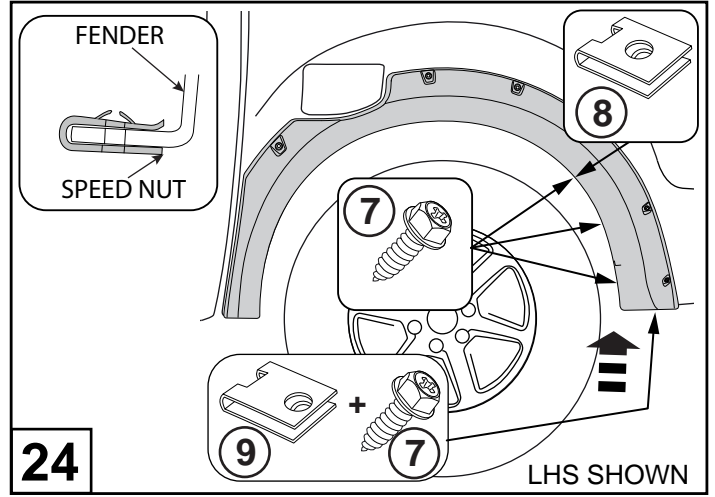

**24** Attach the rear part of the rear fender flare with (3) Hex head screws and factory plastic nuts. Secure the rear lower part with one hex head screw and Speed nuts as shown.

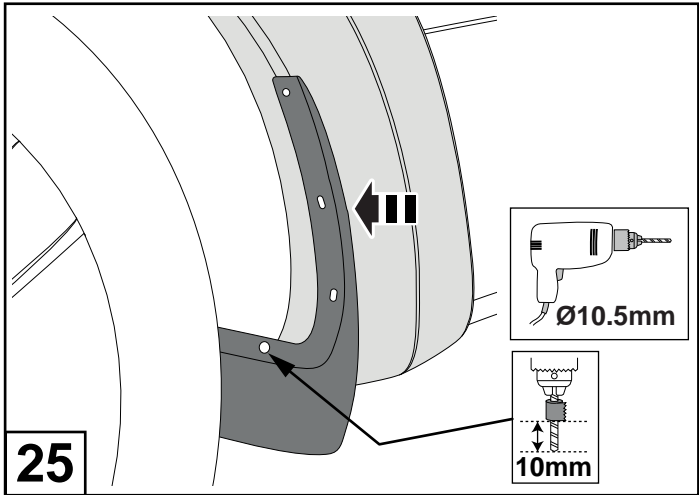

**25** Fit the Mud Flap to the Fender Flare aligning with all the holes. Mark and drill a 10.5mm hole in the liner for the bottom scrivet as shown.

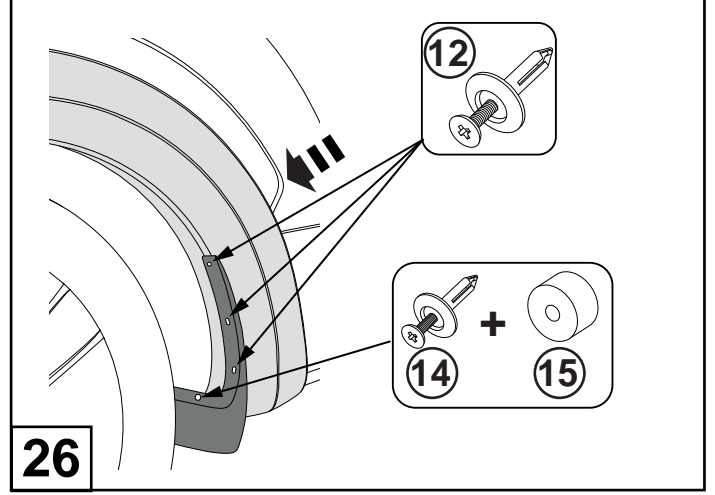

**26** Fit the Mud Flap to the Fender Flare and secure with (3) 6mm plastic scrivets and one 10mm scrivet at the bottom, with one 5mm spacer.

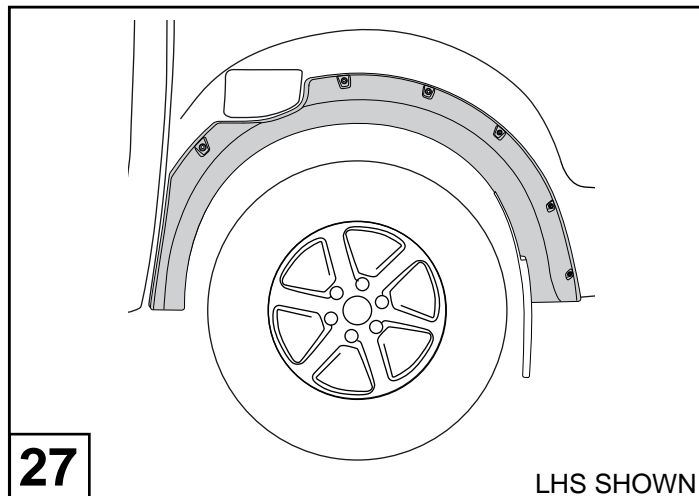

**27** Ensure that flares are aligned. Remove the tape liner. Apply firm pressure on the flare to ensure the tape is contacting the vehicle surface around the full perimeter of the flares.

**FOR THE RHS REAR FENDER FLARE INSTALLATION REPEAT STEPS 16 TO 27**