

FOR VEHICLES WITH OR WITHOUT Active park assist sensor
FORD EVEREST 2016+ ➔

--

--

01/03/21

1/6







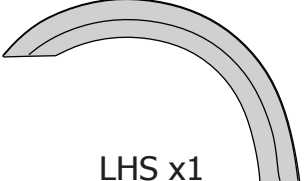
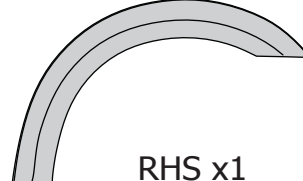
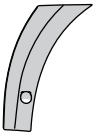
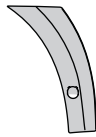

NOTES:

- Ensure that both left and right hand Fender Flares suit the profile of the vehicle.
Note the areas where the Fender Flares come in contact with the vehicle.
- Before fitting Fender Flares remove any mouldings, strips or existing flares from the wheel arch. If there is a body side moulding, mark where the moulding is to be cut, alternatively the Fender Flares can be cut to go around the moulding. Be sure to allow enough room for the extrusion.
- Read instructions carefully. This product must be installed exactly as specified in these instructions.
Failure to do so may result in improper fit and/or retention.

TOOLS REQUIRED

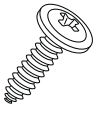
- Mild Soapy Water & Clean Cloths.
- Phillips head Screwdriver.
- Non Permanent Marker / Metal Scribe.
- Steel Ruler.
- Tin Snips.
- Die Grinder.
- Scissors or Sharp Knife.
- Masking Tape.

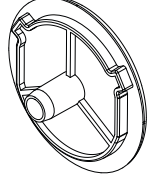
COMPONENTS LIST

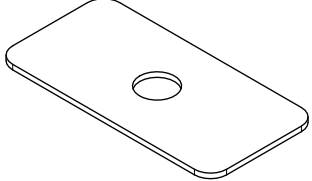
<p>A</p>  <p>LHS x1</p>	<p>B</p>  <p>RHS x1</p>	<p>C</p>  <p>LHS x1</p>	<p>D</p>  <p>RHS x1</p>
<p>E MISC4524</p>  <p>5m</p>	<p>F FAST0086</p>  <p>x24</p>	<p>G CLIP2446PC</p>  <p>x4</p>	<p>H MISC0052</p>  <p>x2</p>
<p>I SCRW0735</p>  <p>x6</p>	<p>J NUTS0198</p>  <p>x6</p>	<p>K MISC1365</p>  <p>x2</p>	<p>L INJM0084-LH/RH</p>  <p>x2 (LH & RH)</p>
<p>M WASH0235</p>  <p>x2</p>	<p>N CLIP3686</p>  <p>x2</p>		

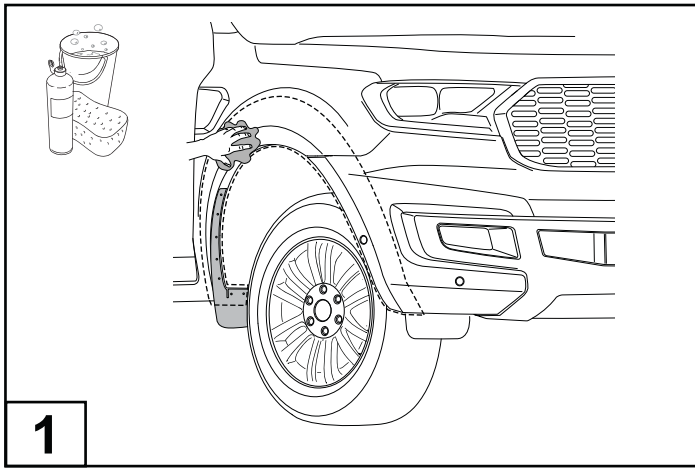

1
Wash the areas of contact on the vehicle and wipe dry both the vehicle and the Fender Flares with a clean cloth. Ensure inside of Fender Flares where extrusion is attached is clean.

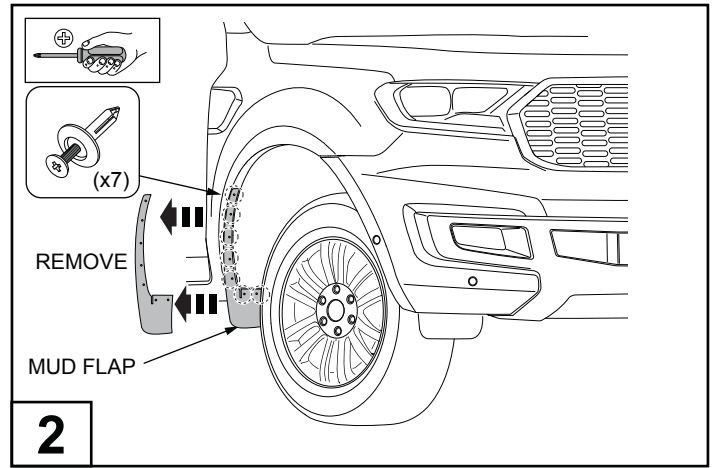

2
Remove the mud flaps by removing and retaining the (7) scrifts from inside the wheel arch as shown. **NOTE:** Replacement scrifts are supplied, if any scrifts are damaged upon removing from the vehicle.

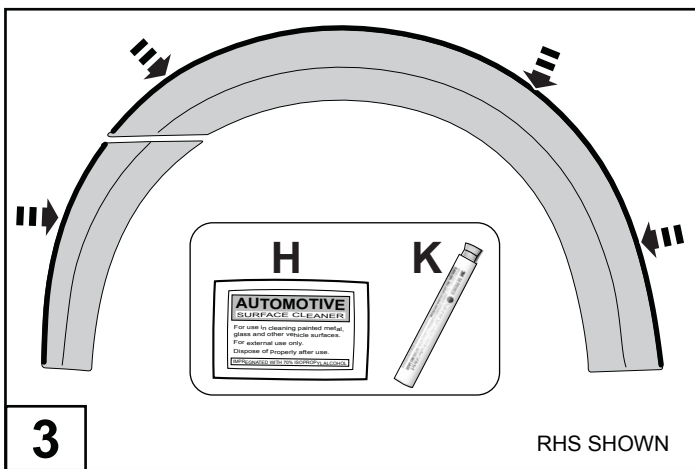

3
Clean the inside edge of each fender flare where the rubber extrusion will adhere with the Alcohol wipe and prime with the Primer Stick supplied. **RHS SHOWN**

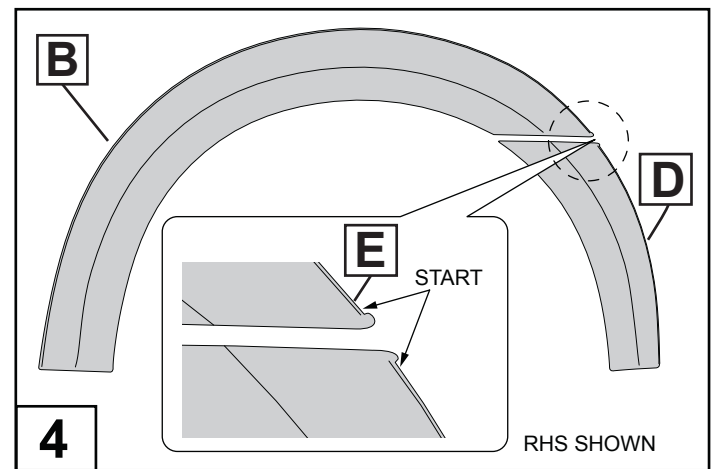

4
Remove approximately 50mm of the protective liner from the extrusion. Fit the extrusion to the Fender Flare along the edge that comes in contact with the vehicle's body panel. **NOTE:** Start applying the extrusion from area shown above. **RHS SHOWN**

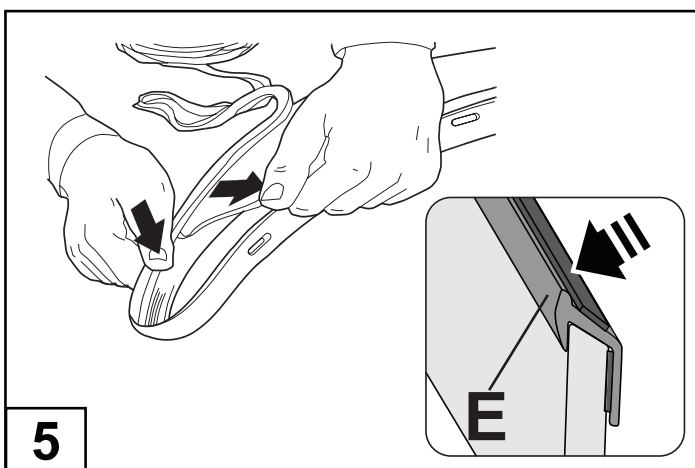

5
Pulling at right angles to the extrusion, remove the liner from the extrusion in small portions and apply thumb pressure to ensure that it adheres to the Fender Flares. Trim any unnecessary extrusion and discard.

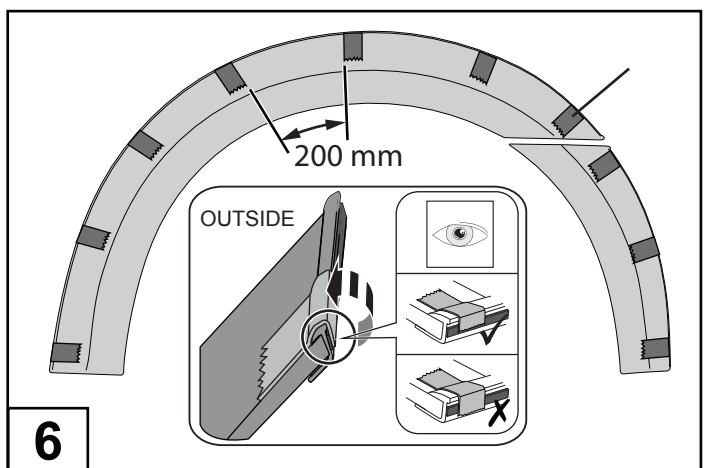

6
Apply masking tape as shown at 200mm intervals or where required to the fender flare extrusion. Fix the tape to the rear of the extrusion over the tape lining and over the front face of the Fender Flare. Ensure the tape does not overlap the tape lining and is not fixed to the inside surface of the fender flare.

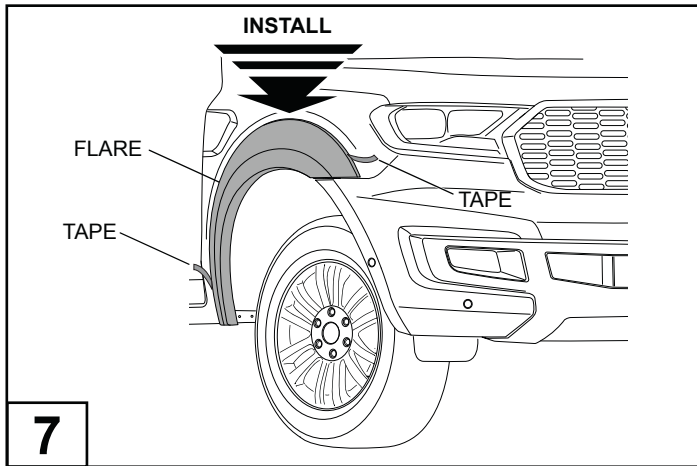

7 Peel back red tape liner, about 50mm from each corner of the adhesive tape on the back of the fender flare. Fit the flare to the vehicle as shown.

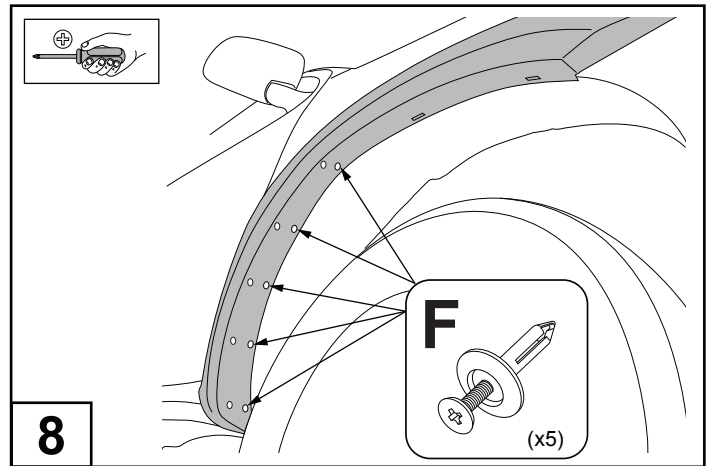

8 Install 5 wheel arch scrivets onto the flare as shown. While pressing and holding the flare in position of best fit.

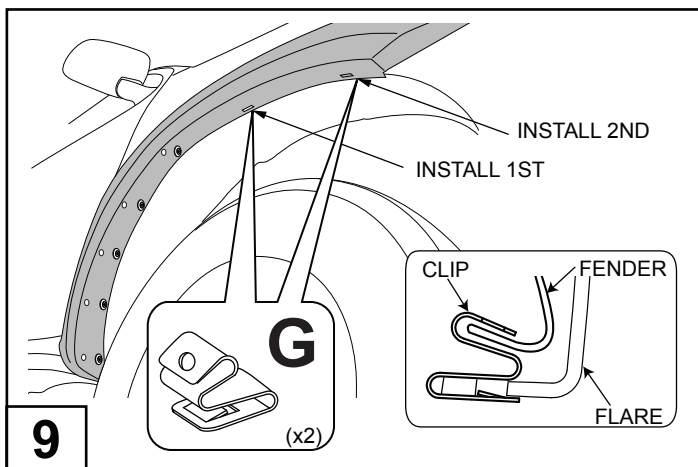

9 Install the clip at an angle, by pushing it on to the fender lip and then rotate downwards. Install the rear clip first and then install the front clip as shown on the picture.

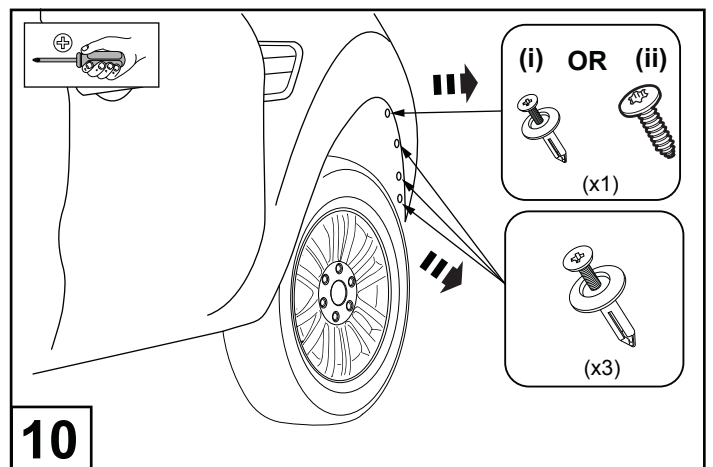

10 Remove all fixing, either (i) (scrivets x4) or (ii) (screw x1 and scrivets x3) from the wheel arch on the front bumper.

FOR VEHICLES NOT EQUIPPED WITH ACTIVE PARK ASSIST COMPLETE THIS STEP & THEN PROCEED TO STEP 17 (FITTING FLARE TO BUMPER)

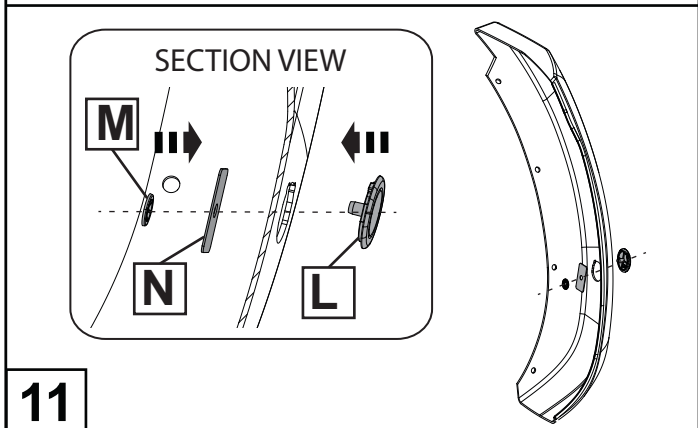

11 Fit the sensor cap and retaining strap to the fender flare, and secure with the starlock washer.

FOR VEHICLES EQUIPPED WITH ACTIVE PARK ASSIST FOLLOW THE NEXT 5 STEPS FITTING THE SENSOR TO THE FLARE ASSEMBLY

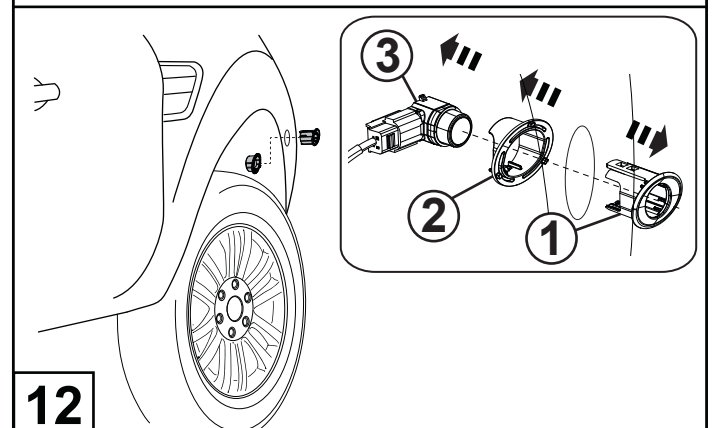

12 Remove Active park assist sensor (3), inner (2) & outer (1) escutcheon from bumper as per the Ford Workshop Manual.

VIEW INSIDE THE FENDER

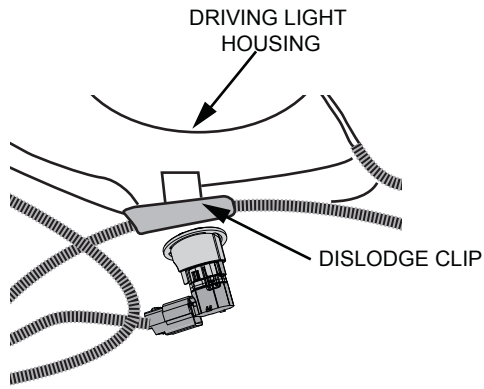

13

Follow the wiring harness that supports Active park assist sensor up to the edge clip located under the driving lamp assembly – dislodge the edge clip from the bumper & leave off permanently.

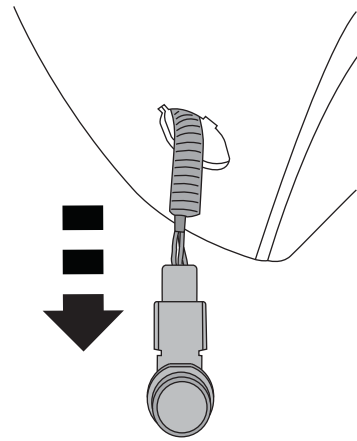

14

Pull extra harness length gently through the OEM hole in the bumper & refit in the Active park assist sensor; leave loosely ready to fit to the fender flare.

SECTION VIEW

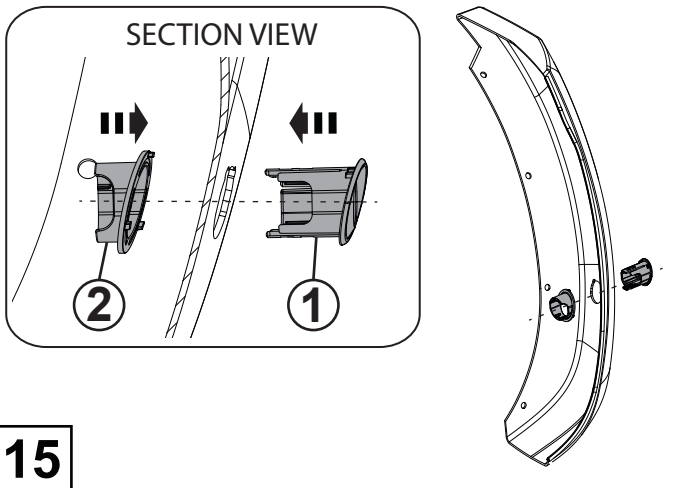

15

Fit inner (2) & outer (1) escutcheon for the Active park assist sensor to the fender flare assembly.

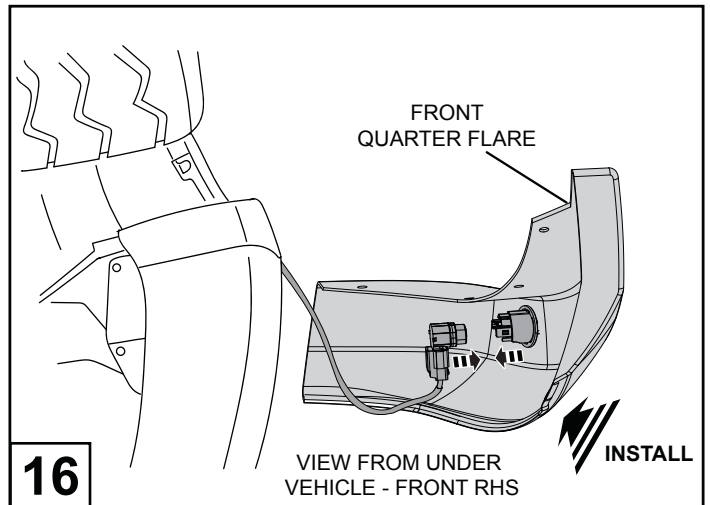

16

Hold fender flare assembly close to the bumper & fit Active park assist sensor to the escutcheon as per the Ford Workshop Manual (note the audible 'click' when the sensor is fully home).

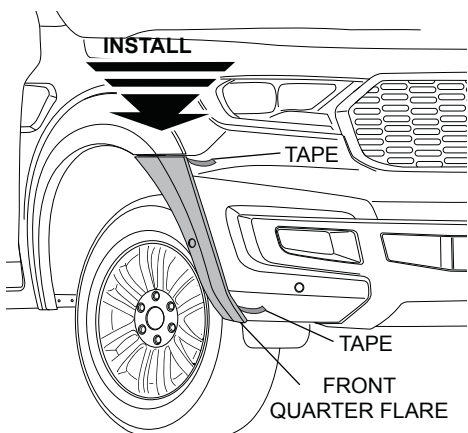

17

Peel back red tape liner, about 50mm from each corner of the adhesive tape on the back of the fender flare. Fit the front quarter flare to the vehicle as shown.

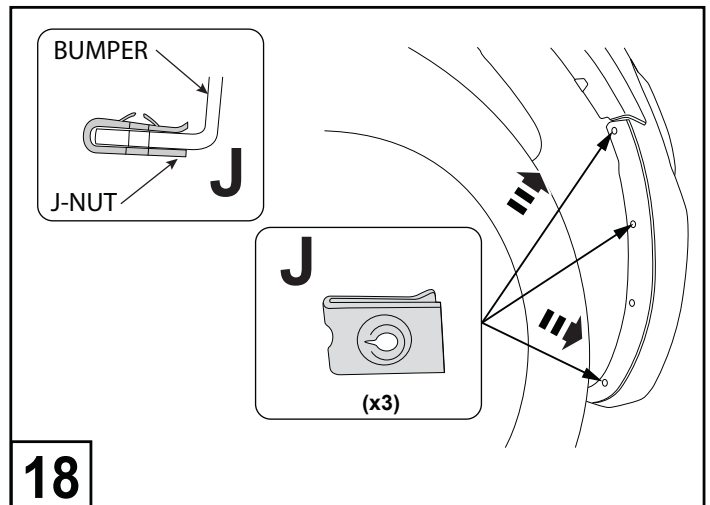

18

Hold the splash guard inwards and either (i) (push J-nut x3 in the top and bottom hole) or (ii) (if vehicle nutsert already exist in top hole, push J-nut in the bottom hole) as shown.

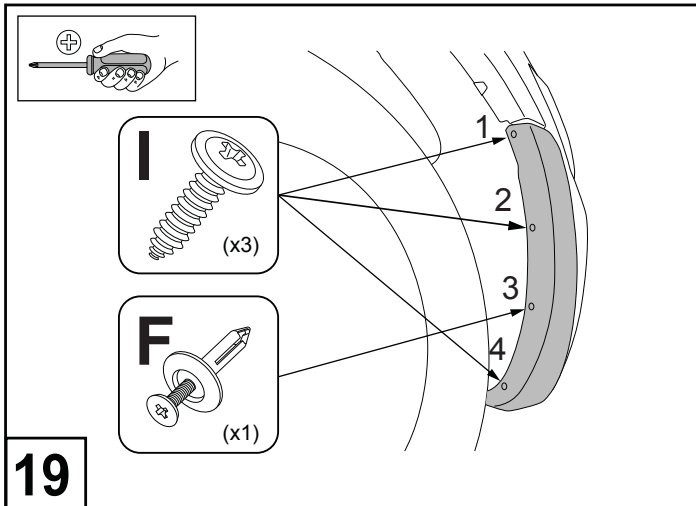

19 Hold the fender flare in the correct position ensuring the trim matches the bumper. Install the fixings as per the order in the image above.

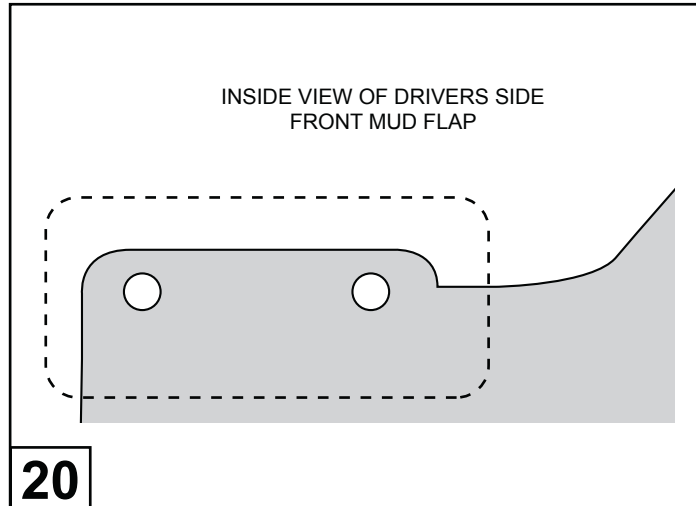

20 Prepare the Front Mud Flap by cleaning them & covering the marked areas with masking tape. Repeat for passenger side Front Mud Flap.

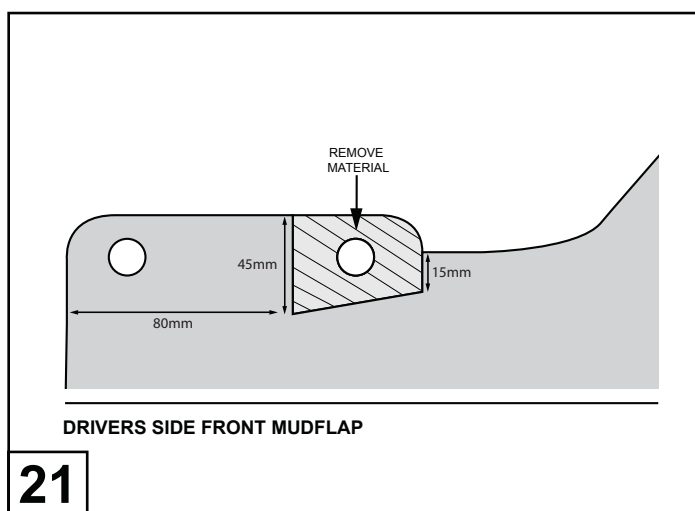

21 Measure & mark the dimensions as per the image on the mudflap. Using tin snips remove the light grey area. Once trimming is done, remove all the masking tape. Repeat for passenger side Front Mud Flap.

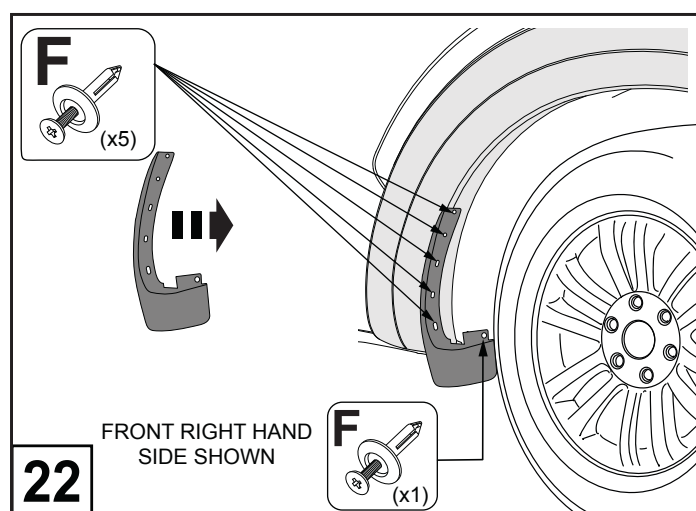

22 Fit the Mud Flaps to the Fender Flare and secure each Mud Flap with six (6) Scrivets supplied as shown.

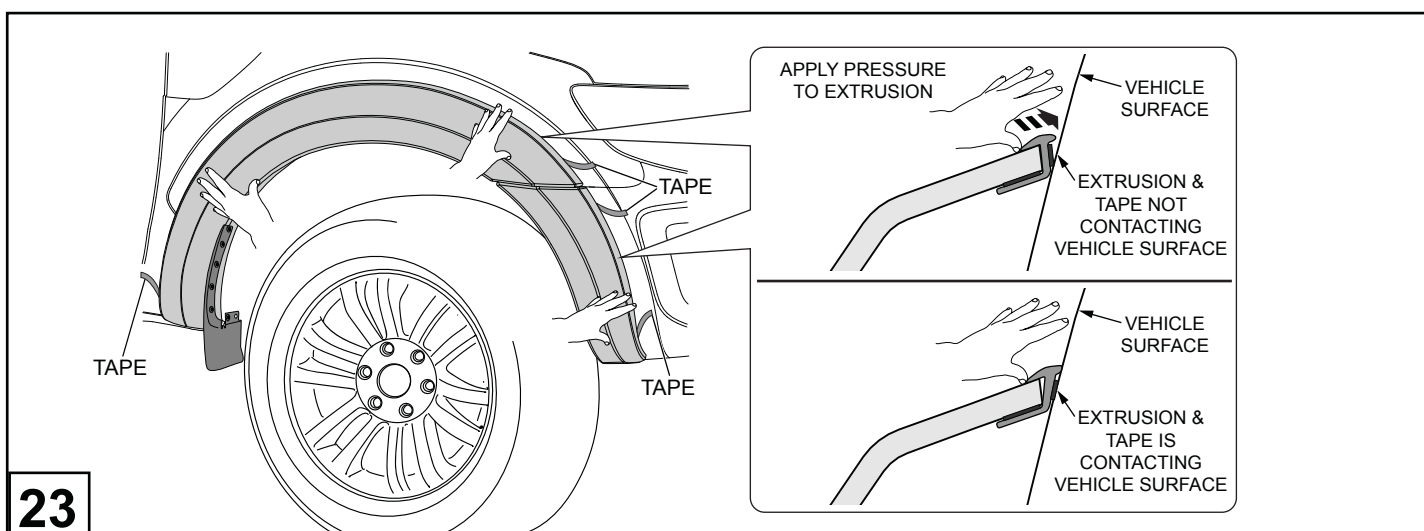

23 Ensure that flares are aligned. Remove the tape liner. Using your thumb and/or fingers apply firm pressure on the extrusion to ensure the extrusion and the tape is contacting the vehicle surface around the full perimeter of the flares.