

REAR FENDER FLARES INSTALLATION INSTRUCTIONS

FF899
1/4

ISUZU D-MAX 2018-

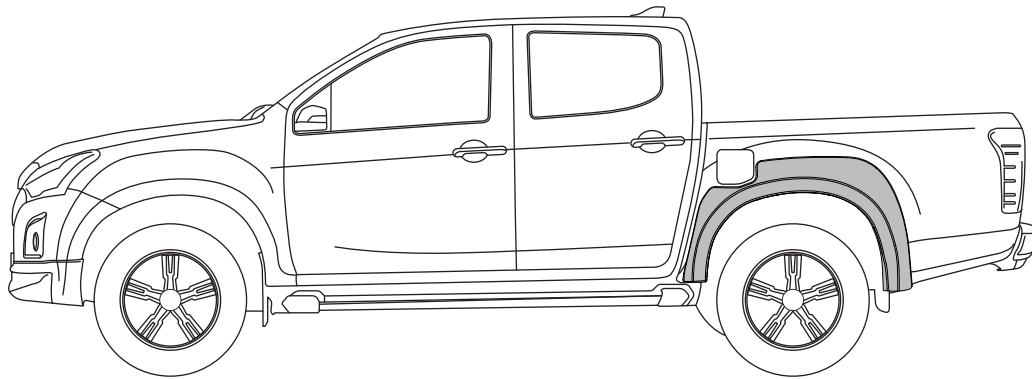

NOTES:

- Ensure that both left and right hand Fender Flares suit the profile of the vehicle. Note the areas where the Fender Flares come in contact with the vehicle.
- Before fitting Fender Flares remove any mouldings, strips or existing flares from the wheel arch. If there is a body side moulding, mark where the moulding is to be cut, alternatively the Fender Flares can be cut to go around the moulding. Be sure to allow enough room for the extrusion.
- Read instructions carefully. This product must be installed exactly as specified in these instructions. Failure to do so may result in improper fit and/or retention.

PAINTING INSTRUCTIONS:

⚠ Warning: Do not fit trim edge extrusion or any of the hardware until paint is completely dry.

- Spot Sand Fender Flares where required prior to painting, recommend 500 grit using an orbital type sander.
- Prior to painting, clean all surfaces to be painted using clean water and a mild detergent, do not use lacquer thinner or any solvent based products. Wipe completely dry.
- Best results will be achieved by wiping the areas to be painted with a tack rag just prior to painting.
- Select a top coat and clear paint that is suitable for ABS (Acrylonitrile-Butadiene-Styrene).
- Automotive paint systems, such as Acrylics or Two Packs, can be applied directly to the components. However, some paints may require a primer. If recommendations on paint specifications are not followed, cracking of the part or degradation to the material may result. In all paint systems, aromatic hydrocarbons and alkalis are best avoided to reduce damage to the material properties.
- If using a paint system which requires baking, do not expose the product to temperatures above 70° C (155° F).
- Allow a minimum of 8 hours after baking before installation on the vehicle.

Tools required for this fitment:

- Drill, Ø6mm Drill Bit & 10mm Drill Stop.
- Phillips head Screwdriver.
- Non Permanent Marker / Metal Scribe.
- Steel Ruler.
- Tin Snips.
- Die Grinder.
- Scissors or Sharp Knife.
- Masking Tape
- Mild Soapy Water & Clean Cloths.

PARTS IN FITTING KIT

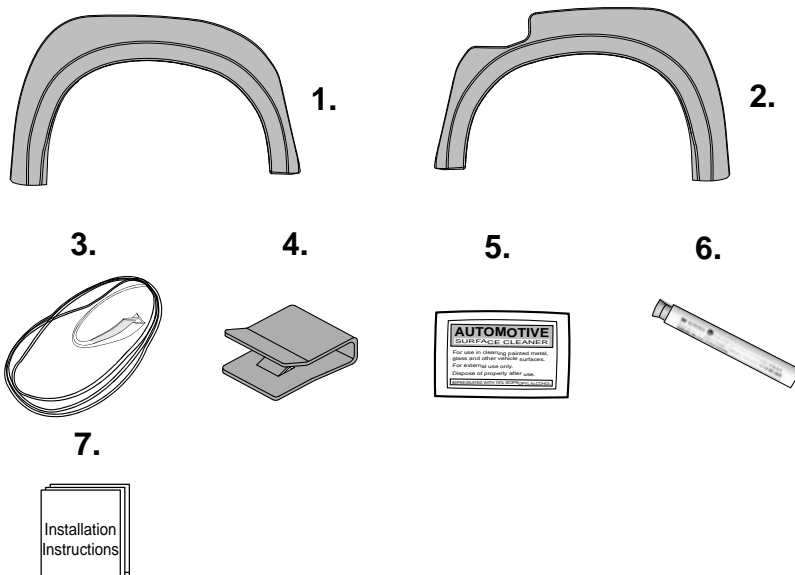

NO.	COMPONENT	QTY
1	Rear Fender Flare (RHS)	1
2	Rear Fender Flare (LHS)	1
3	Extrusion	5m
4	Narrow Clip	4
5	Alcohol Wipe	3
6	Primer Stick	3
7	Installation Instructions	1

REAR FENDER FLARES INSTALLATION INSTRUCTIONS

FF899
2/4

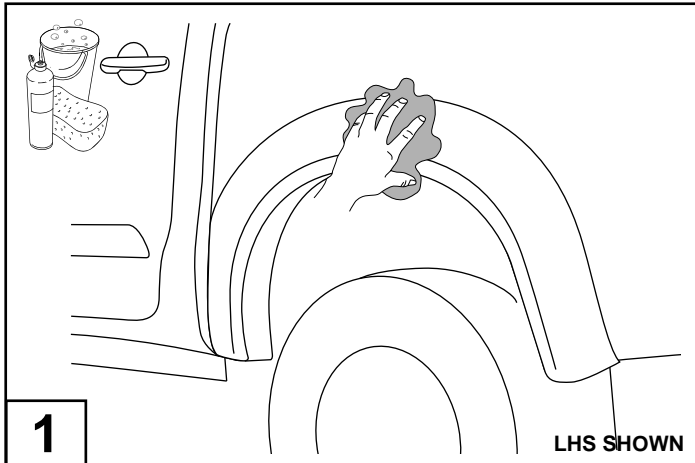

1 Wash the areas of contact on the vehicle and wipe dry both the vehicle and the Fender Flares with a clean cloth. Ensure inside of Fender Flares where extrusion is attached is clean.

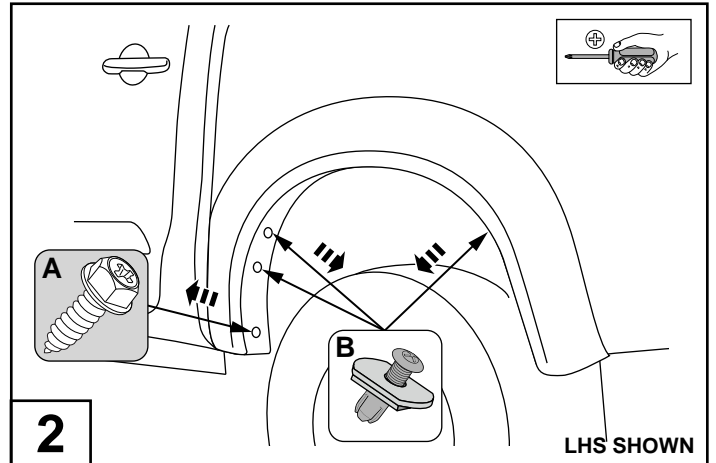

2 Remove and retain (3) plastic scrivenets (B) from the wheel arch. Remove and retain (1) screw (A) from the fender.

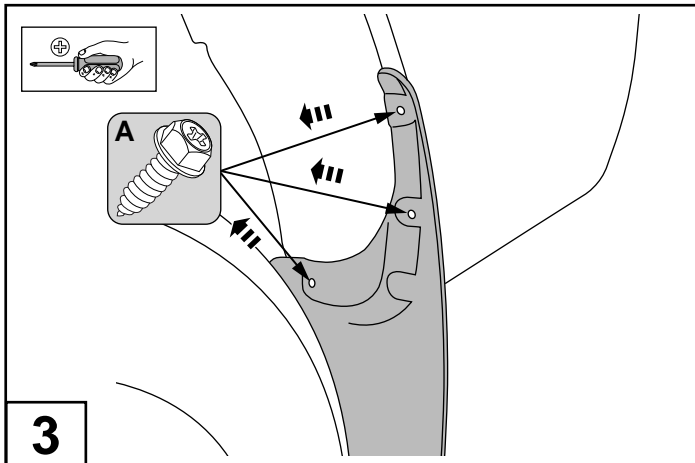

3 Remove the mud flaps by removing and retaining the (3) screws (A) from inside the wheel arch as shown.

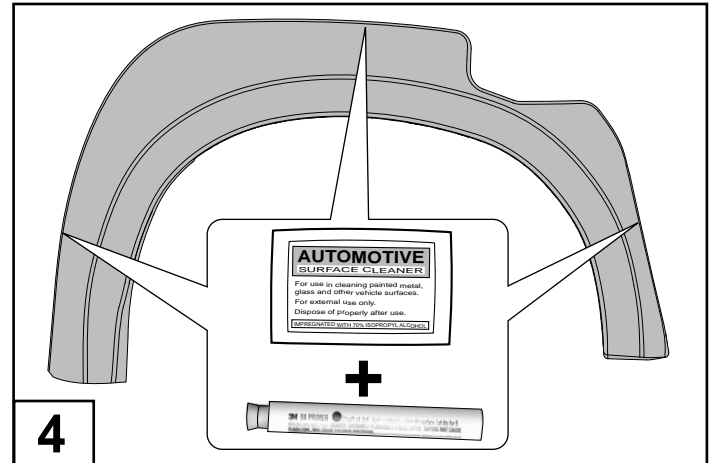

4 Where the rubber extrusion will adhere, clean the inside edge of each fender flare with alcohol wipe and apply primer.

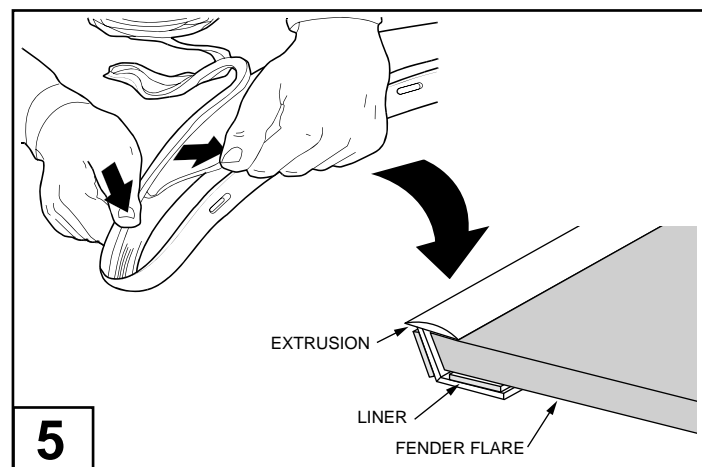

5 Remove approximately 50mm of the protective liner from the extrusion. Fit the extrusion to the Fender Flares along the edge that comes in contact with the vehicle's body panel. Trim any unnecessary extrusion and discard.

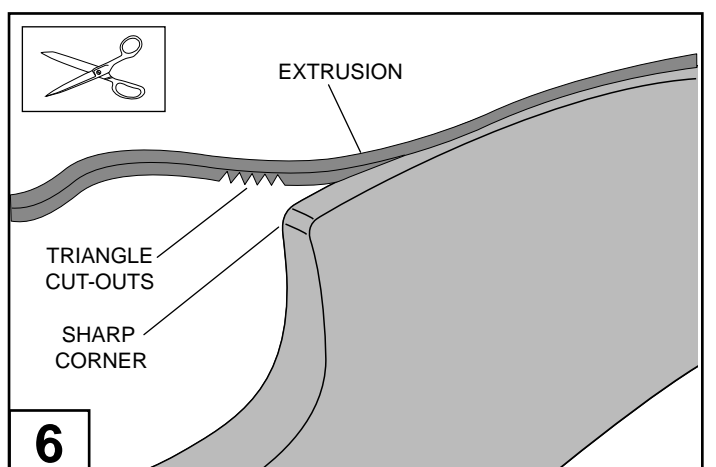

6 To fit the extrusion around sharp corners, cut a multiple triangles out of the extrusion where it meets the sharp corners as shown.

REAR FENDER FLARES INSTALLATION INSTRUCTIONS

FF899
3/4

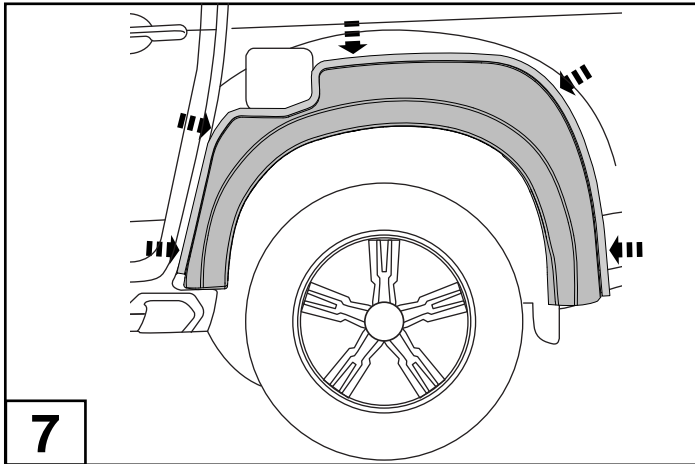

7

Place and hold the flare against the car and get a second person to mask the border around the flare using masking tape. Remove the flare and use alcohol wipes to clean 10mm of the selected area and then apply a prime stick in the selected area.

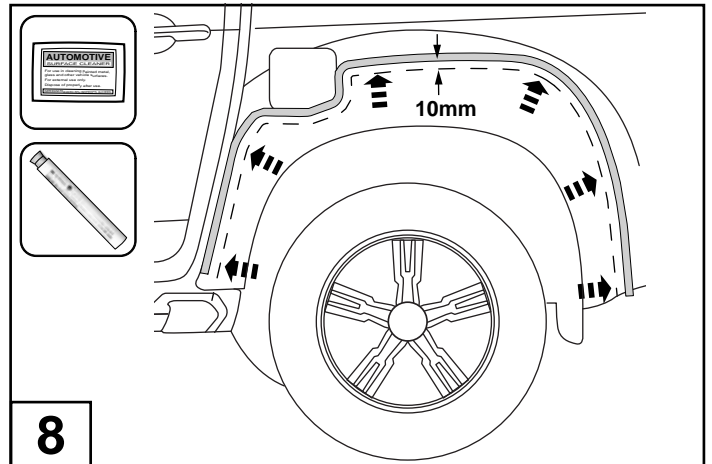

8

Remove the flare and use alcohol wipes to clean 10mm of the area inside side from the tape and apply a prime stick.

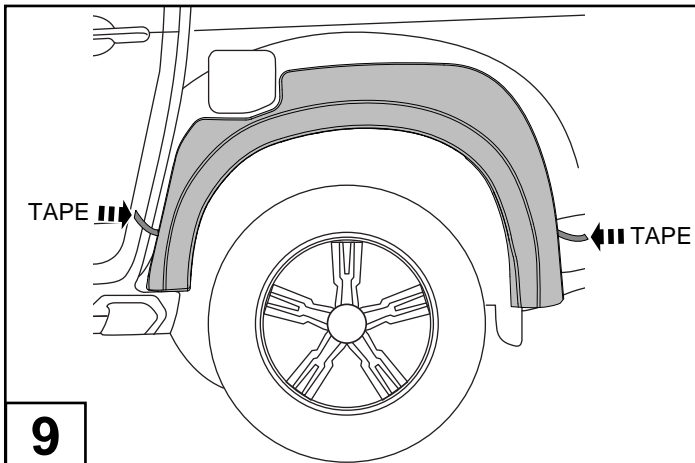

9

Peel back red tape liner, about 50mm from each corner of the adhesive tape on the back of the fender flare. Fit the flare to the vehicle as shown.

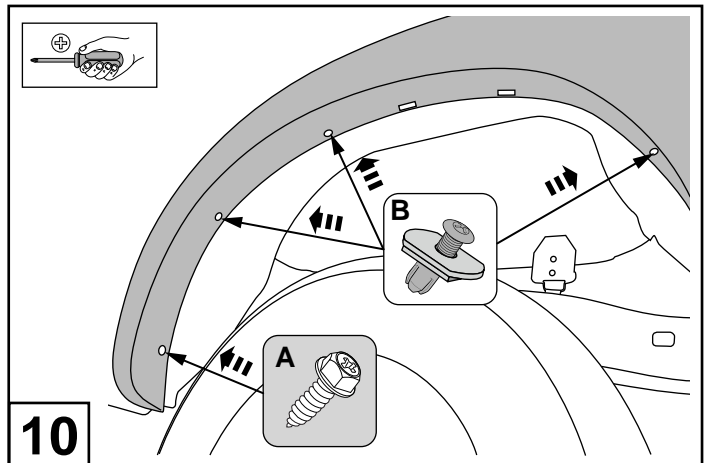

10

Secure the Fender Flare with (2) previously removed screw (A) and (3) plastic scrivenets (B).

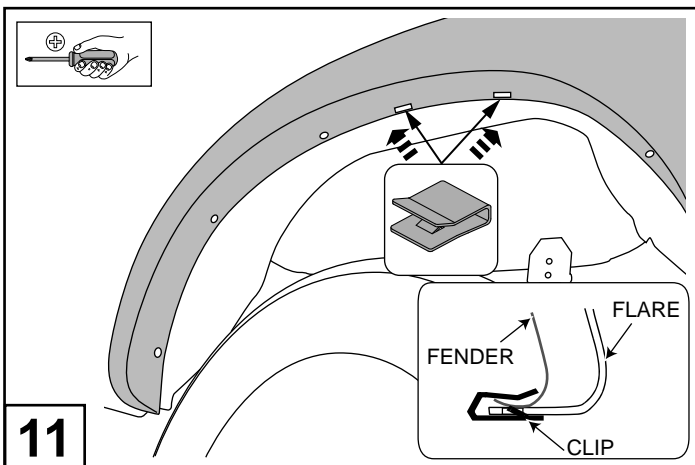

11

Fit (2) narrow clip as shown, ensuring the notch in the clip locates securely into the slot in the Fender Flare.

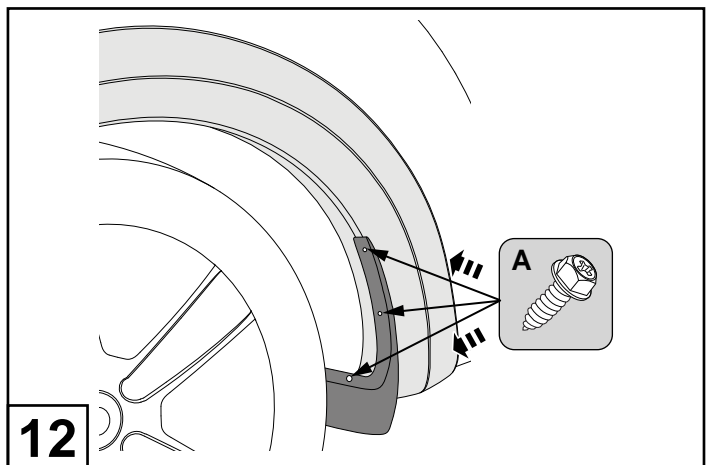

12

Fit the Mud Flap to the Fender Flare and secure with three (3) screws (A) as shown.

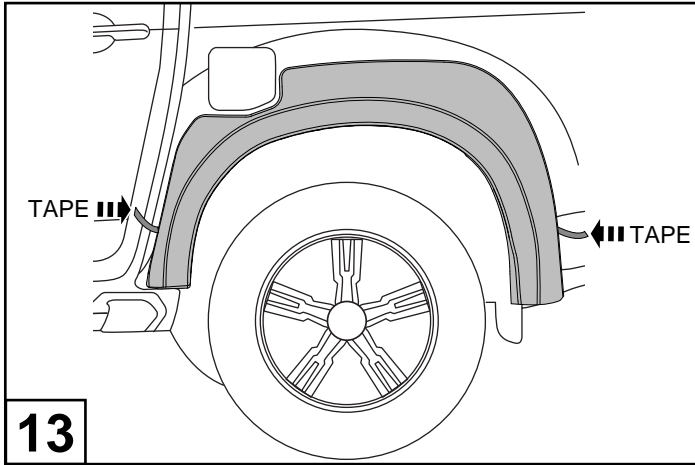

Remove the tape liner. Apply firm pressure on the flare to ensure the tape is contacting the vehicle surface around the full perimeter of the flares.