

WARNING!

When in the closed position, Aluminium Tonneau Cover must be latched and tailgate must be closed. Failure to do so could result in unexpected opening of the Tonneau Cover from sudden wind gusts or driving conditions, which could cause damage to the vehicle and/or your Aluminium Tonneau Cover.

Secure any items tall enough to strike the Tonneau Cover lock mechanism.

DO NOT close the Tailgate when the Aluminium Tonneau is in the closed position, as damage may occur to the vehicle and/or your Tonneau Cover.

Do not operate vehicle while cover is open.

MAINTENANCE:

- Avoid the use of chemicals to clean painted surfaces, wash regularly with car wash detergent, hose off and chamois dry. Aluminium top sheet finish can be maintained with briteshine polish or similar. Un-maintained product i.e. surface finish degradations not covered by warranty.
- The gas struts are self lubricating and should only be cleaned occasionally with a damp cloth. Premature seal failure will result if solvents or lubricants are used to clean struts.
- Gas struts must be connected with the cylinder (wide) end to the Aluminium Tonneau Cover or Warranty is Void.
- The locking mechanisms and latches only require occasional lubrication with Graphite Powder.
- DO NOT use any other lubricants or oils. Using alternative products will VOID Warranty.
- All installation hardware and fasteners must be checked every so often for tightness.

TONNEAU COVER - IMPORTANT:

- Read instructions carefully before installation. It is strongly recommended that installation is conducted by a qualified mechanic.
- This product must be installed exactly as specified in these instructions. Failure to do so may result in improper fit and/or retention.
- Do not stand/sit or rest heavy objects on Tonneau Cover.
- Humans or animals are not to be under the closed Tonneau Cover at any time.
- Securely latch Tonneau Cover before operating vehicle.
- Do not carry open volatile chemicals with Tonneau Cover installed.
- If contact with volatile chemicals occurs clean Tonneau Cover with mild detergent and water solution.
- Recommend installation by 2 people.
- Fitting Instructions must be given to the end customer to understand correct removal and replacement process onto the vehicle.

Care Instructions:



Clean Tonneau Cover with a mild detergent and water solution.



Do not use abrasive cleaners or solvents.

Tonneau Cover Assembly x1	Hinge Bracket x2	Striker Bracket x2	Striker x2
M10 Nut x8	M10 Washer x8	Gas Strut x2	Ball Stud x4
M8 Lock Nut x4	M8 Washer x2	Gas Strut Bracket x2	M6 Button Head Cap Screw x4
M6 Washer x4	Hinge Bracket Fixing Plate x2	Tailgate Lock Bracket x2	4.8x10 Rivets x12
4.8x2 Rivets x15	4.8x2 Rivets x26	Striker Bracket Spacer 3mmx2	Striker Bracket Spacer 15mm x2

REQUIRED TOOLS | EQUIPMENT

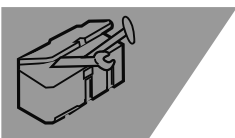

- | | | |
|----------------------------------|-----------------|-----------------------------------|
| 13mm and 17mm Socket | 4mm Allen Key | Cleaning Materials |
| ½" Drive Ratchet + Extension Bar | Rivet Gun | Masking Tape |
| 8mm, 13mm and 17mm Spanner | Tape Measure | Right Angle |
| Power Drill | Centre Punch | Rust Inhibitor |
| 5mm Drill Bit | Hammer | Personal Protective Equipment: |
| 8 mm Drill Bit | Pencil / Marker | Safety Glasses, Ear Plugs, Gloves |
| | | (Scissors, Silicone)* Optional |

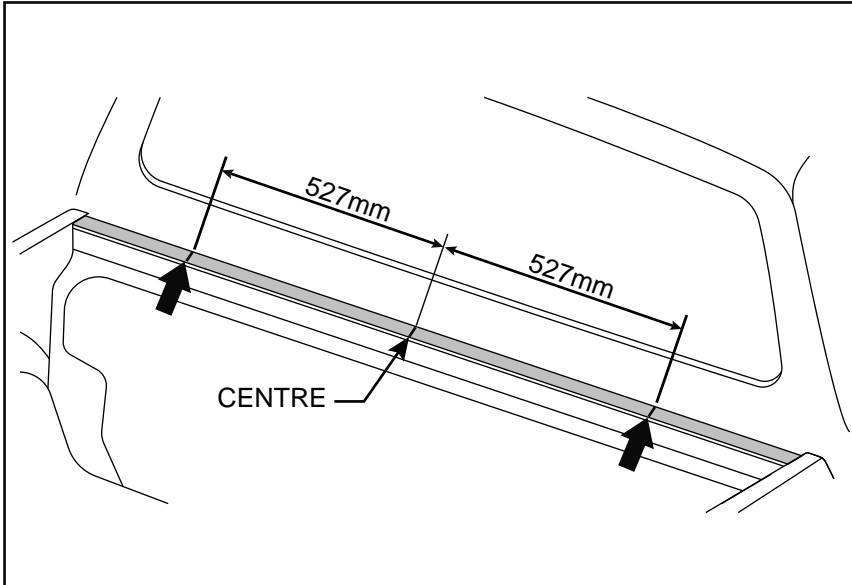

Step 1

Required tools: Masking Tape, Marker Pen and Tape Measure.

- Clean the top surface of the tub.
- Apply masking tape on front rail top surface
- Mark a centre line accurately. Mark lines 527.0mm from the centre line to both sides.

Note: This instruction is for plain tub installation only. If tub liner is fitted, the liner will need to be trimmed to allow correct installation of the tonneau cover brackets and hinges. No spacers or additional media allowed between hinges/brackets and the vehicle tub.

Note: If fitted, cabin guard must be removed.

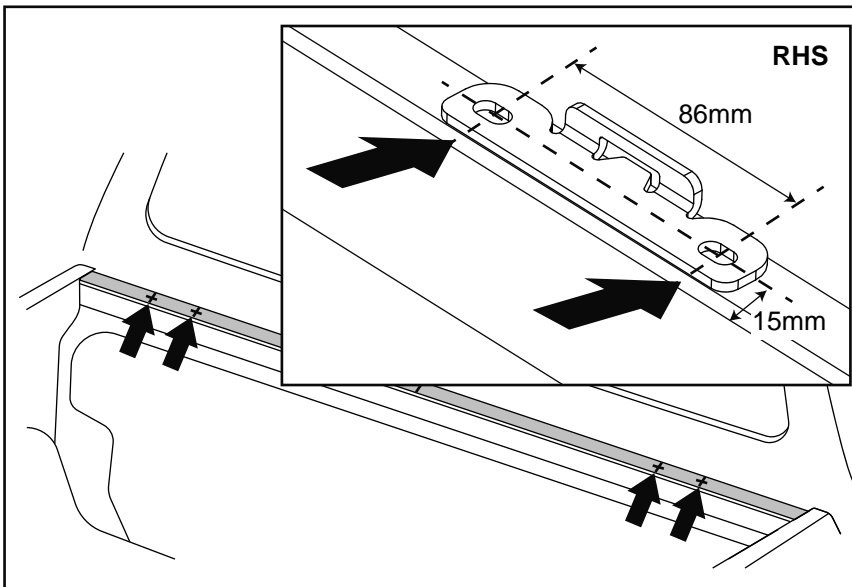

Step 2

Required tools: Masking Tape, Marker Pen and Tape Measure.

- At the two marked lines, mark another line 86mm outboard from this line, and a line 15mm from front rail inner surface, crossing both lines (use right angle and tape measure). RHS shown in detail.
- Align Hinge Bracket to marked lines and check alignment.
- Repeat for both sides.

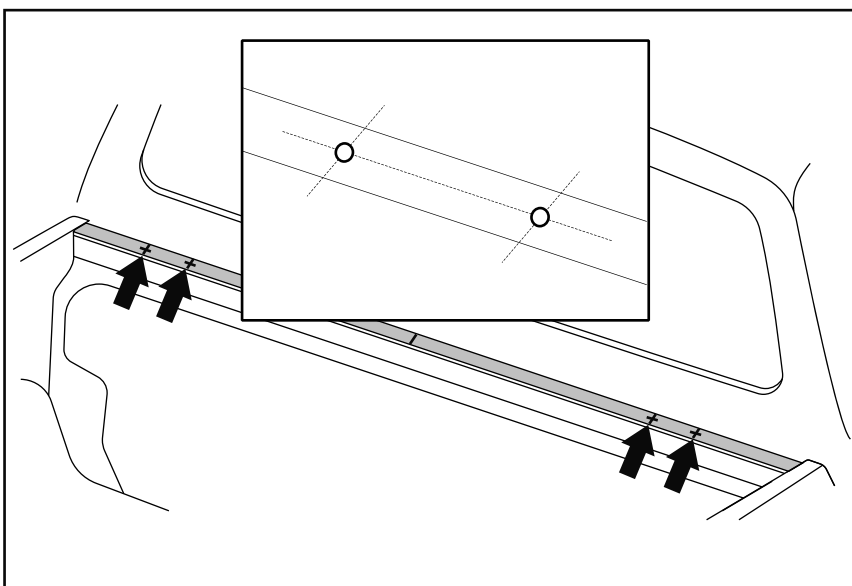

Step 3

Required tools: Power drill, 8mm drill bit and drill bit stopper, centre punch, hammer.

- Centre punch the two hole locations.
- Drill holes using a 8mm drill bit.
- Remove drill burr from the holes.
- Apply rust inhibitor to the drilled holes.
- Repeat for other side.

Note: Use drill stopper to avoid drilling too deep.

Note: Set drill stopper at 15mm.

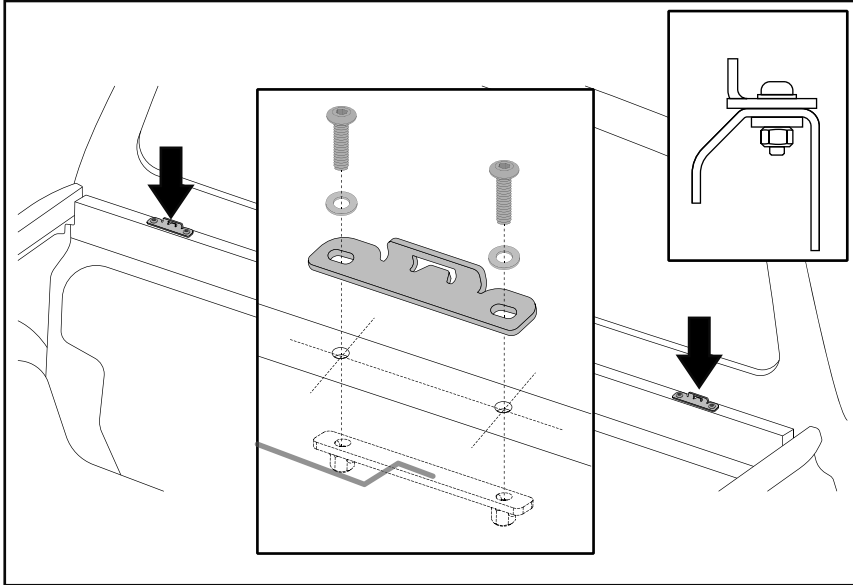

Step 4

Required tools: 4mm Allen Key.

- Position hinge bracket fixing plate inside the tub front rail, holding it by the wire to allow positioning the plate under the holes.
- Position hinge bracket and secure with supplied M6 bolts, washers to the hinge fixing bracket. Finger tighten only.
- Repeat for both sides.
- Align both Hinge Brackets equal distance from the front rail inner surface and tighten the bolts to 10Nm.

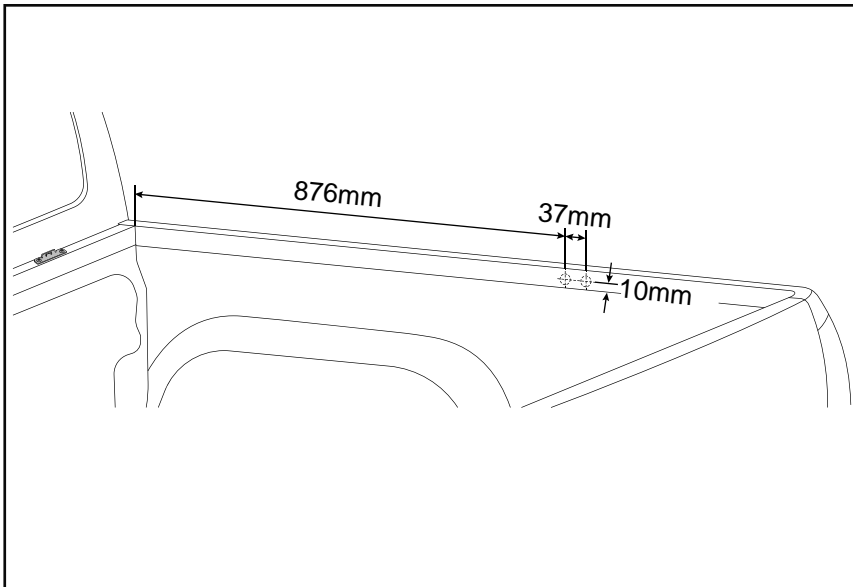

Step 5

Required tools: Masking Tape, Marker Pen and Tape Measure.

- Apply masking tape to the side rail inner surface and measure 876mm from the front rail inner surface, and mark location.
- Mark another line 37mm from this line, and a line 10mm from the bottom edge of the side rail, crossing both lines.
- Align Gas Strut Bracket with marked lines to confirm hole locations.

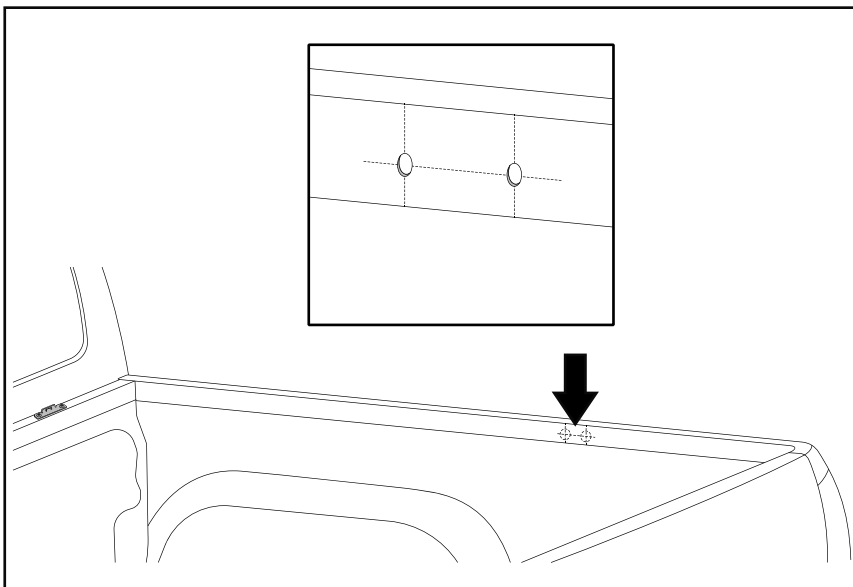

Step 6

Required tools: Power drill, 5mm drill bit and drill bit stopper, centre punch, hammer.

- Centre punch the two hole locations.
- Drill holes using a 5mm drill bit.
- Remove drill burr from the holes.
- Apply rust inhibitor to the drilled holes.
- Repeat for other side.

Note: Use drill stopper to avoid drilling too deep.

Note: Set drill stopper at 10mm.

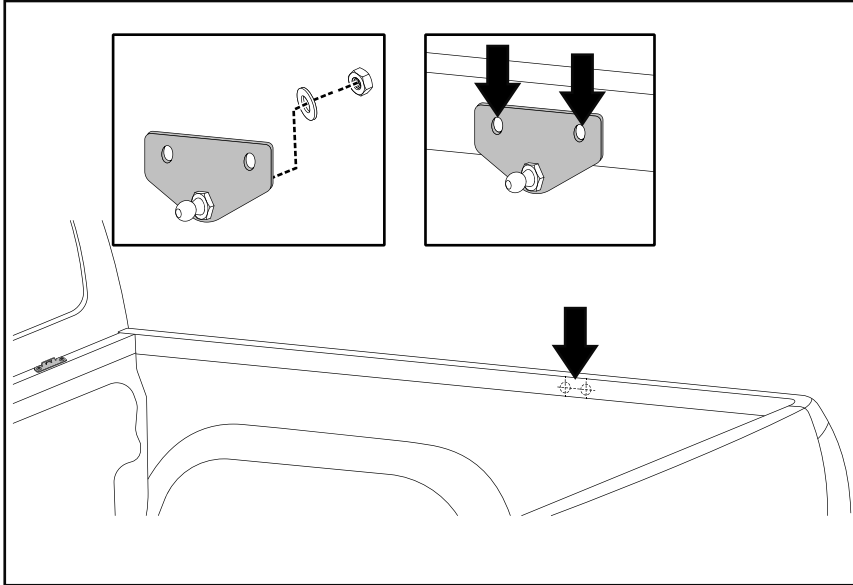

Step 7

Required tools: Rivet gun, 13mm spanner and 13mm socket and driver.

- Install the pivot end ball to the bracket and tighten it to 20.0 Nm.
- Install the gas strut bracket with supplied rivets.
- Repeat for both sides.

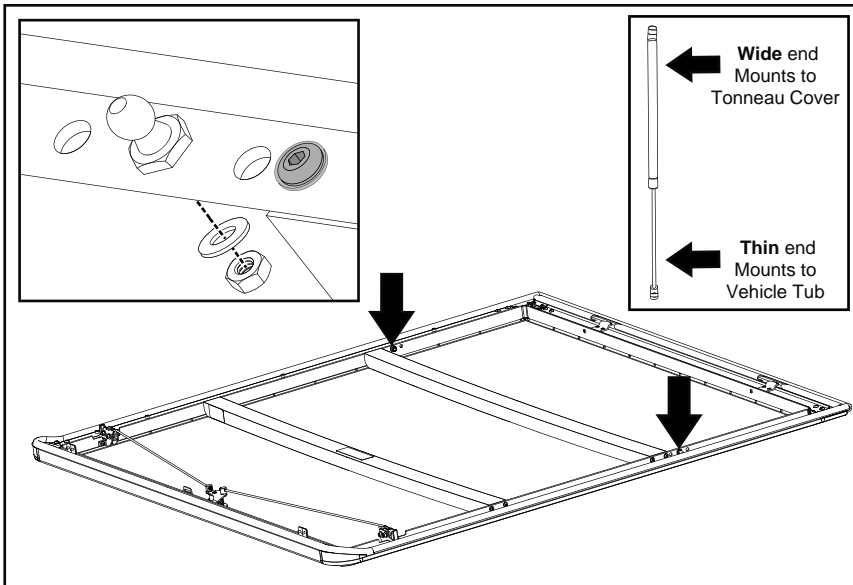

Step 8

Required tools: 13mm spanner, 13mm socket and driver.

- Install the ball stud with supplied nut and washer in the middle hole of the Tonneau. (Ball Stud to outside).
- Connect the wide end of gas strut by pressing it onto the ball stud.
- Repeat for both sides.

Note: The opening height of the tonneau cover can be adjusted by fixing the ball studs in either holes illustrated.

Note: Ensure the gas strut is installed in the correct orientation as shown. The wide end connects to the Tonneau cover.

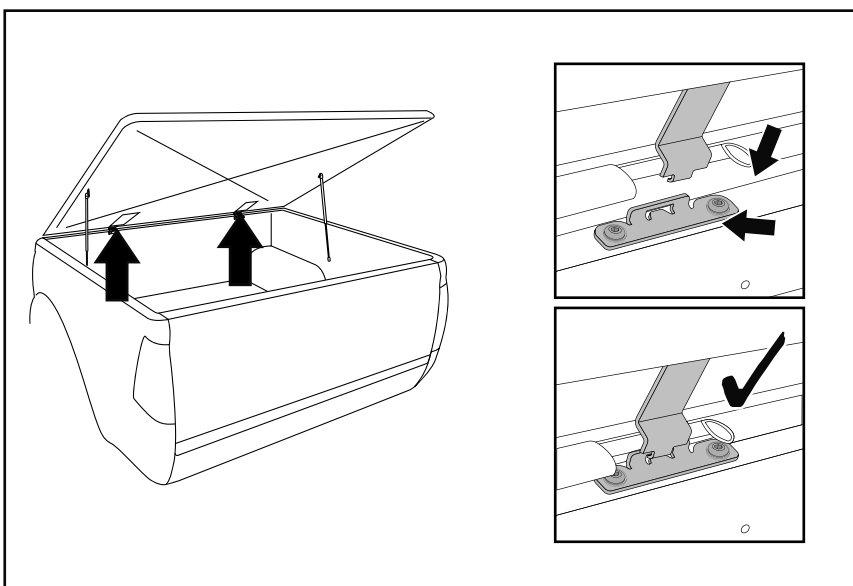

Step 9

Required tools:

- Install the cover by letting the hinge tongue to rest on front of the hinge groove while holding the cover in a 60° angle.
- Move the cover toward the vehicle cabin to slide the tongue to the groove, ensure hinge parts fully engage.
- **Do not lower the cover yet.**

Note: When lowering the cover, ensure the front seal is not crushed between the front rail and the cover.

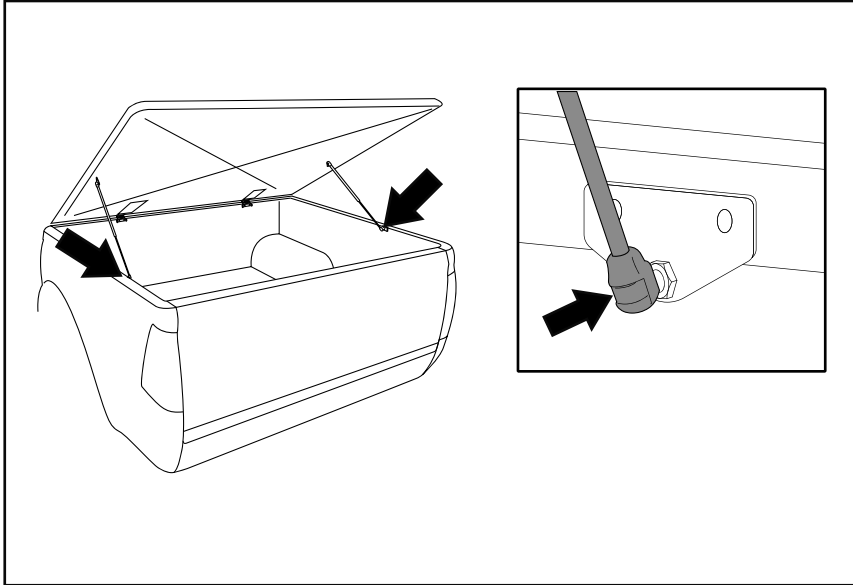
**Step 10****Required tools:**

- Attach gas struts to brackets by clipping into place. Ensure narrow end mounts to the vehicle.

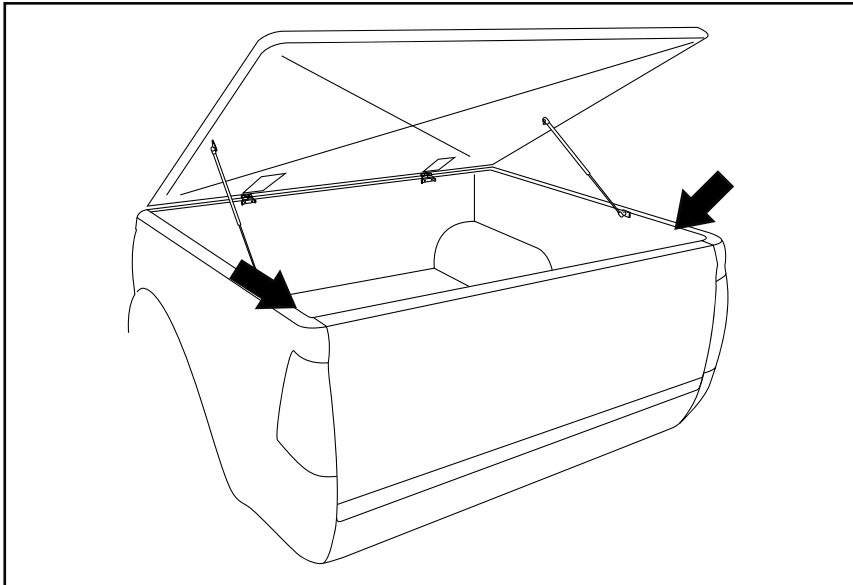
**Step 11****Required tools:**

- Close the cover by pulling from the handle and slowly close it while checking that the cover is correctly lined up to the tub and the latch mechanisms are not touching the tub's side rails.
- Once confirmed the cover is lined up correctly, leave it fully open.

Note: If the cover does not line up correctly, move hinge parts mounted to the front rail forward or backward, one at the time.

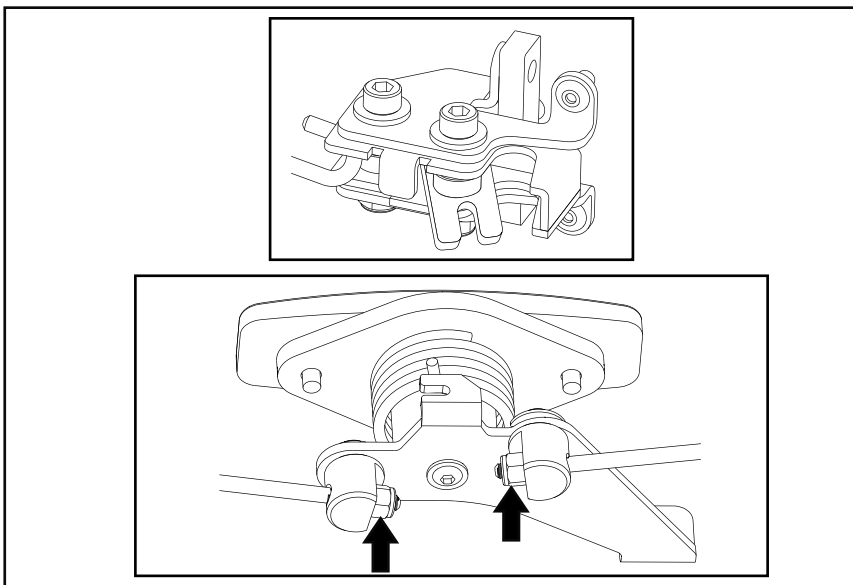
**Step 12****Required tools:** 8mm Spanner.

- While the cover is open and tailgate is open. Press the latch rotor to closed position, both sides.
- Rotate the handle slowly to clock-wise, ensure both latches disengage at the same time. Adjustment may be required.

Note: Mechanism can be adjusted by tightening or loosening the latch rod M5 nuts from underneath the cover.

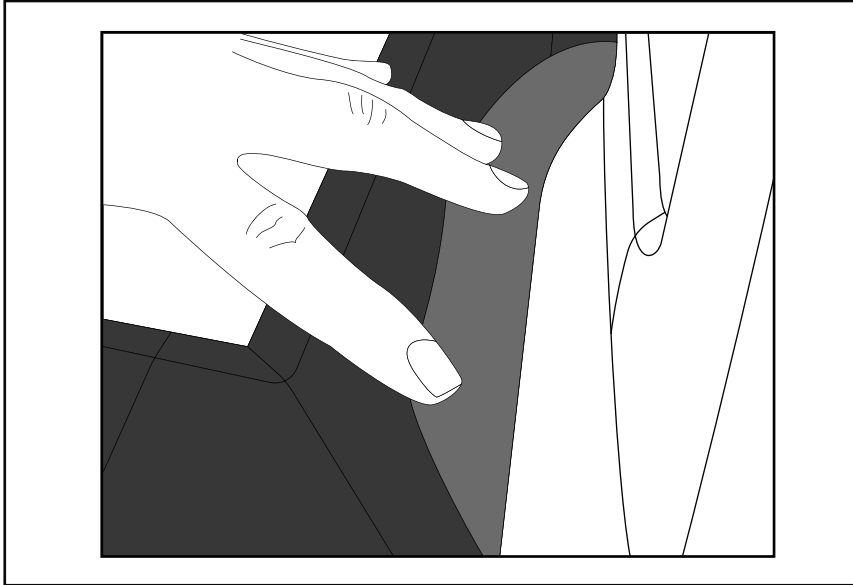
**Step 13****Required tools:**

- While the cover is open, check the front seal's lip is not trapped between the cover and the front rails by bending it up.

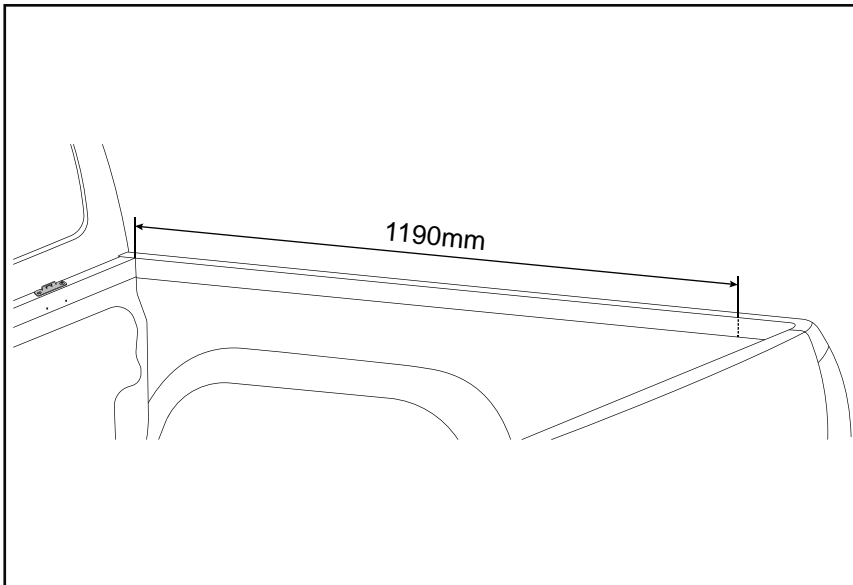
**Step 14****Required tools:** Masking Tape, Marker Pen and Tape Measure.

- Apply masking tape to the rear section of the side rails and side wall below.
- Using tape measure, marks line 1190mm from the front rail inner surface.

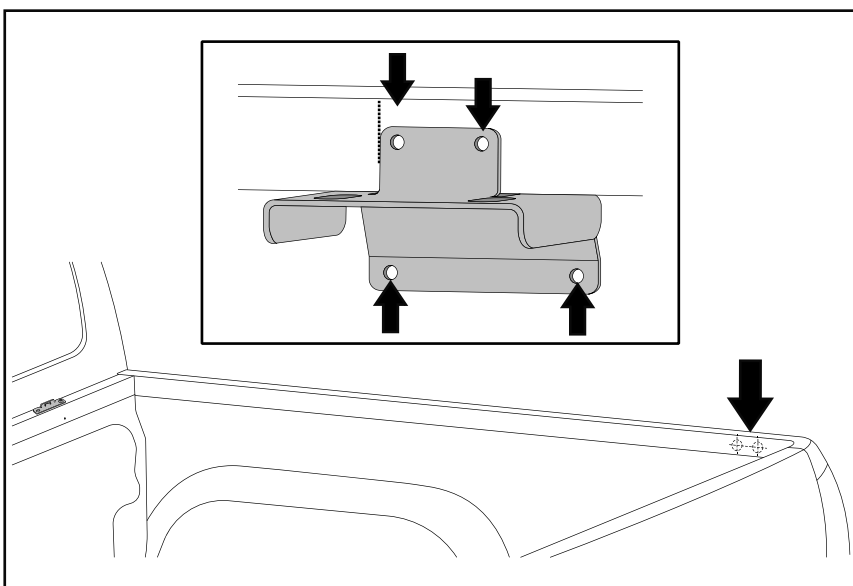
**Step 15****Required tools:** Marker Pen

- Align the top left side of the striker bracket with the marked location while holding up against the underside of the side rail.
- Mark the four hole locations, using the bracket as template.
- Do this for both sides.

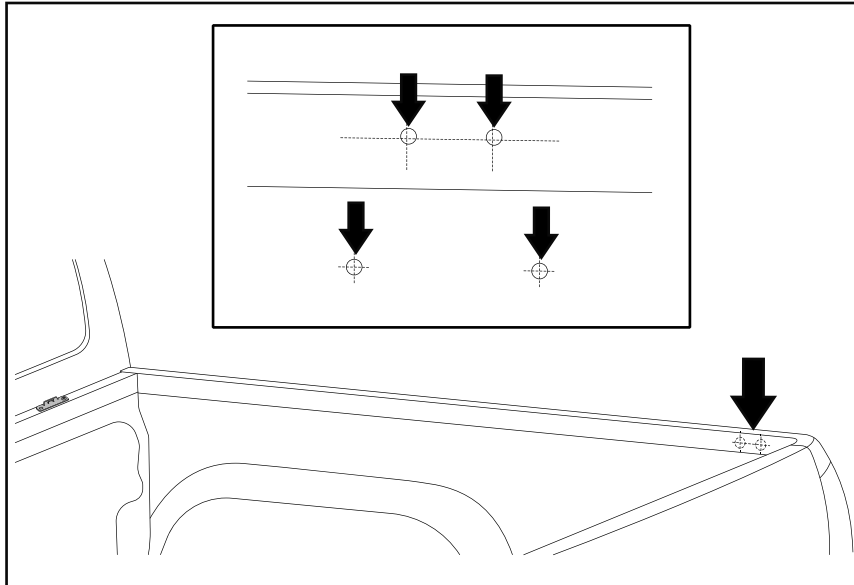

Step 16

Required tools: Power drill, 5mm drill bit and drill bit stopper, centre punch, hammer.

- Centre punch the four hole locations.
- Drill holes using a 5mm drill bit.
- Remove drill burr from the holes.
- Apply rust inhibitor to the drilled holes.
- Repeat for other side.

Note: Use drill stopper to avoid drilling too deep.

Note: Set drill stopper at 10mm.

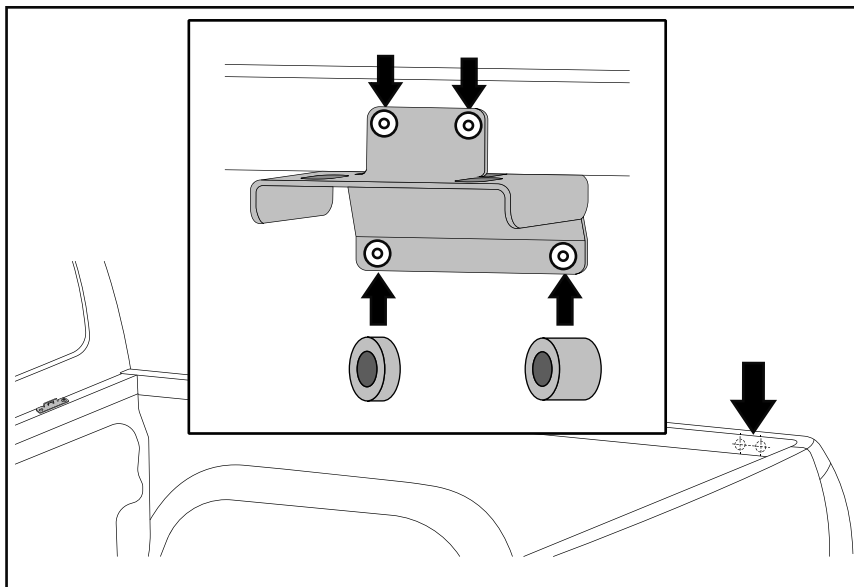

Step 17

Required tools: Rivet gun.

- Position the spacers behind the bracket at the lower rivet positions, 3mm spacer at the forward most point, 15mm spacer at the rearward most point.
- Install the bracket using supplied rivets, 4.8x10mm rivets for the upper mounting points, 4.8x15mm rivet for the forward most lower mounting point, 5.8x26mm rivet for the rearward most lower mounting point.
- Repeat for other side.

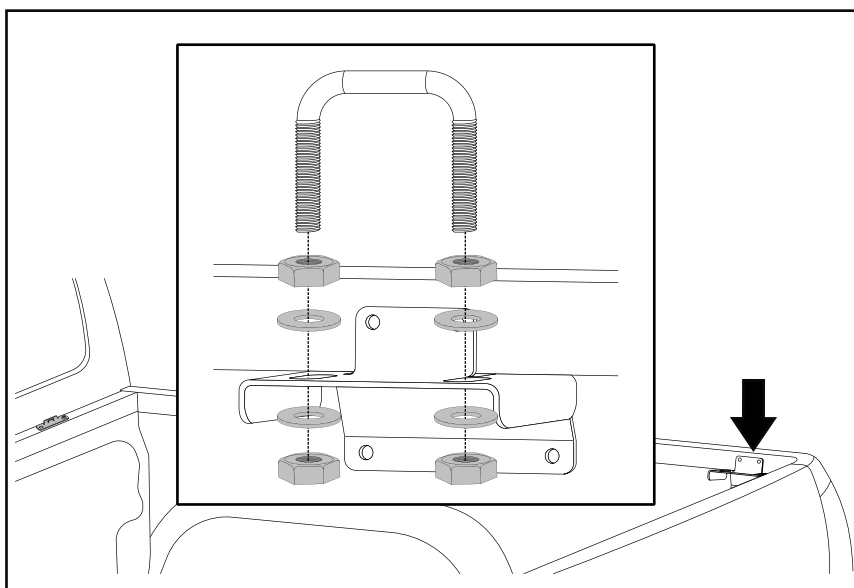

Step 18

Required tools: 17mm spanner, 17mm socket and driver.

- Install the striker to the striker bracket using supplied hardware.
- The striker should line up with the top surface of the side rails, fine adjustment required.
- Repeat for other side.

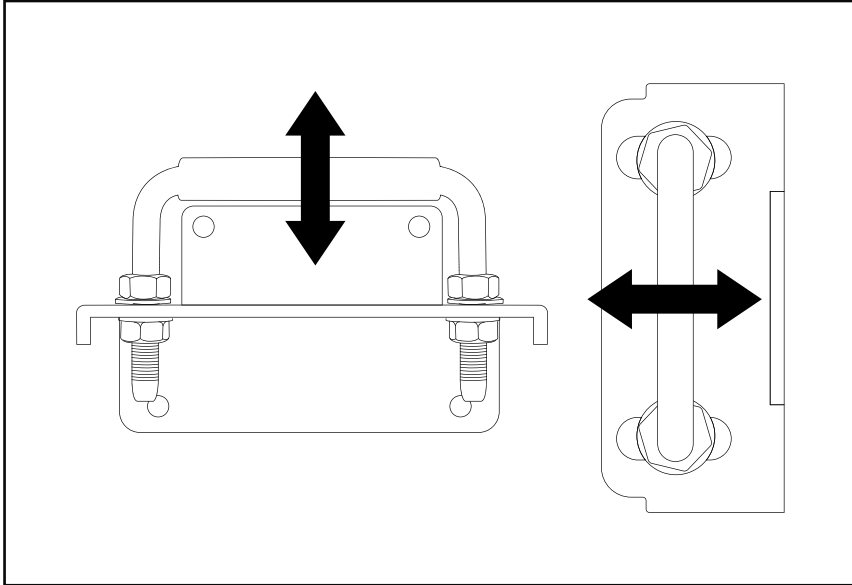

Step 19

Required tools: Masking Tape, Marker Pen and Tape Measure.

- Slowly close the cover and move the striker sideways to line it up with the latches. Ensure both sides are lined correctly.
- Adjust the striker height correct by first closing the cover and measuring the gap between the cover and side rails top surface. The gap should be 9.0 mm at the rear, adjust strikers accordingly.
- Tighten the striker nuts to 30.0Nm.

Note: Do Not Close the tailgate.

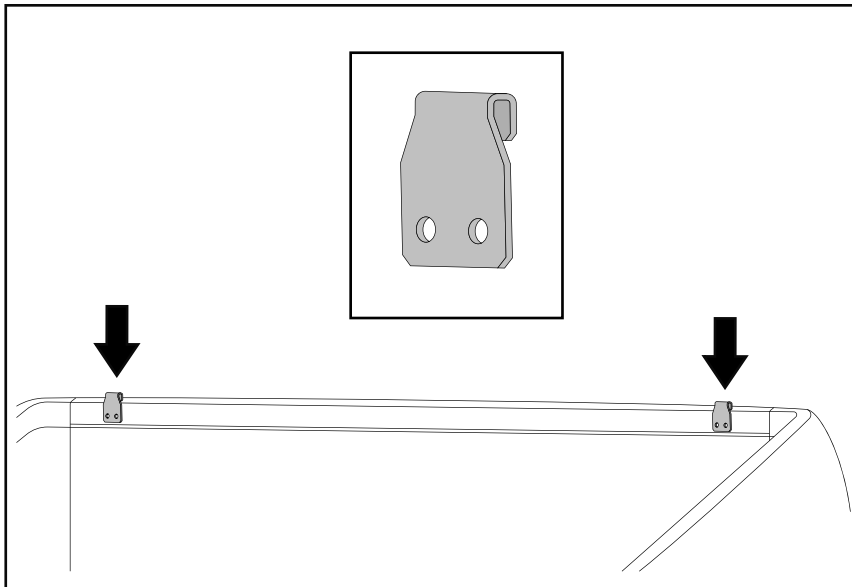

Step 20 (Optional - Tailgate Locking Brackets)

Note: Tailgate locking brackets are included for added security, if you do already have tailgate lock installed or do not require this feature, please go to step 25.

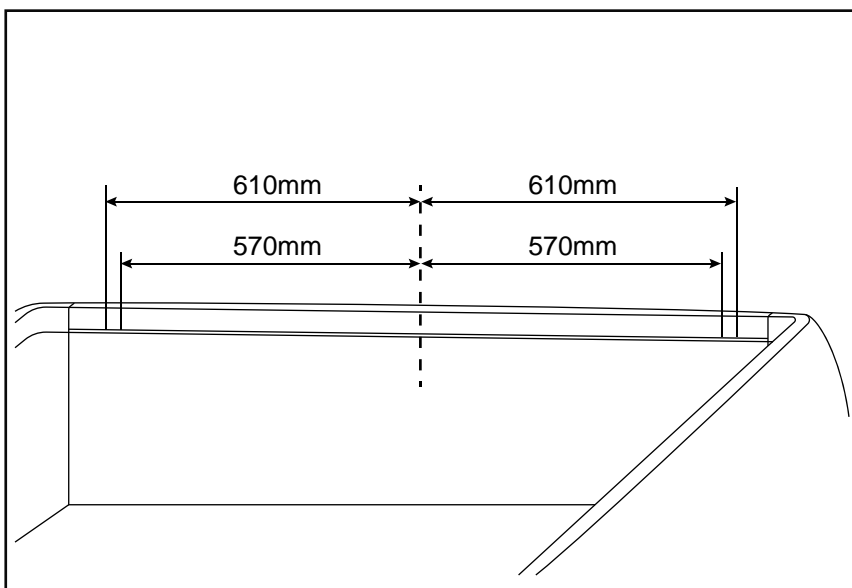

Step 21 (Optional)

Required tools: Masking Tape, Marker Pen and Tape Measure.

- Apply masking tape on both corner of the tailgate top surface and first 30mm of inner surface.
- Mark a centre line accurately.
- Mark a line 610mm either side of the centre line.
- Mark a line 570mm either side of the centre line.

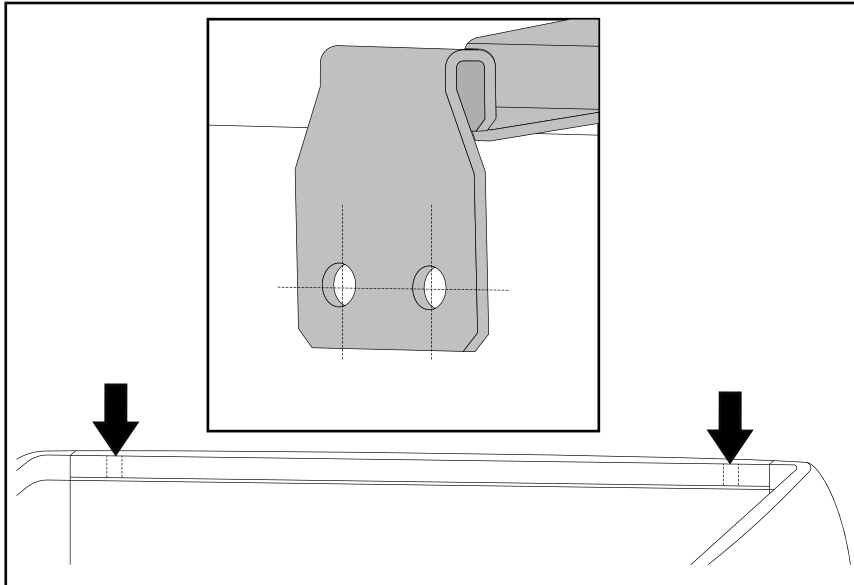
**Step 22 (Optional)****Required tools:** Marker Pen

- Align tailgate lock bracket with marked lines to confirm hole location.
- Use the other bracket to create a gap between the tailgate top surface and tailgate lock bracket.
- Mark the hole locations, using the bracket as a template.
- Repeat for the other side.

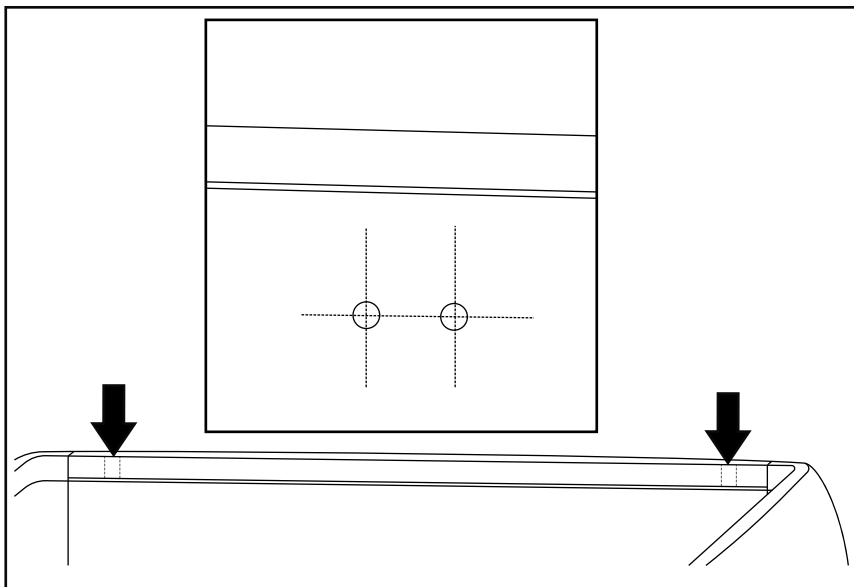
**Step 23 (Optional)****Required tools:** Centre punch, hammer, drill, 5mm drill bit, drill bit stopper.

- Centre punch the four hole locations.
- Drill holes using a 5mm drill bit.
- Remove drill burr from the holes.
- Apply rust inhibitor to the drilled holes.

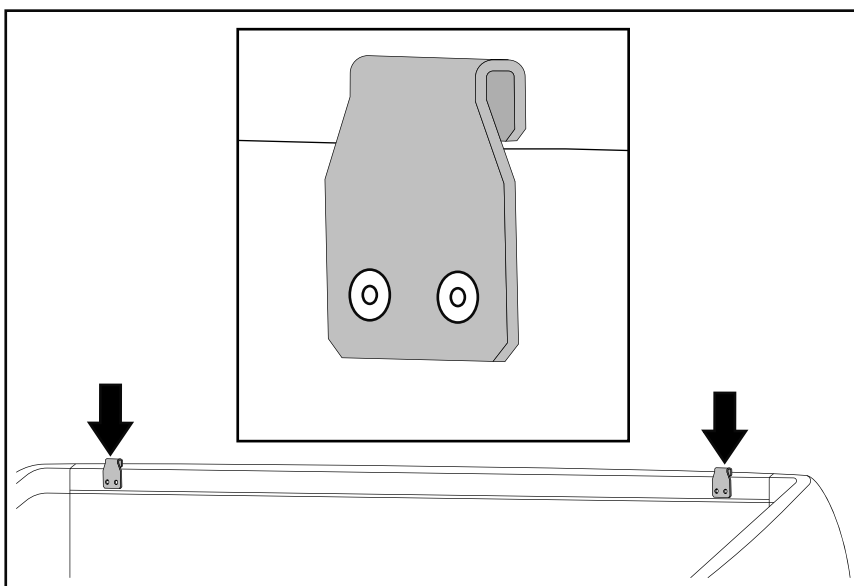
Note: Use drill stopper to avoid drilling too deep.**Note:** Set drill stopper at 15mm.**Step 24 (Optional)****Required tools:** Rivet gun.

- Install the tailgate lock brackets with supplied rivets.

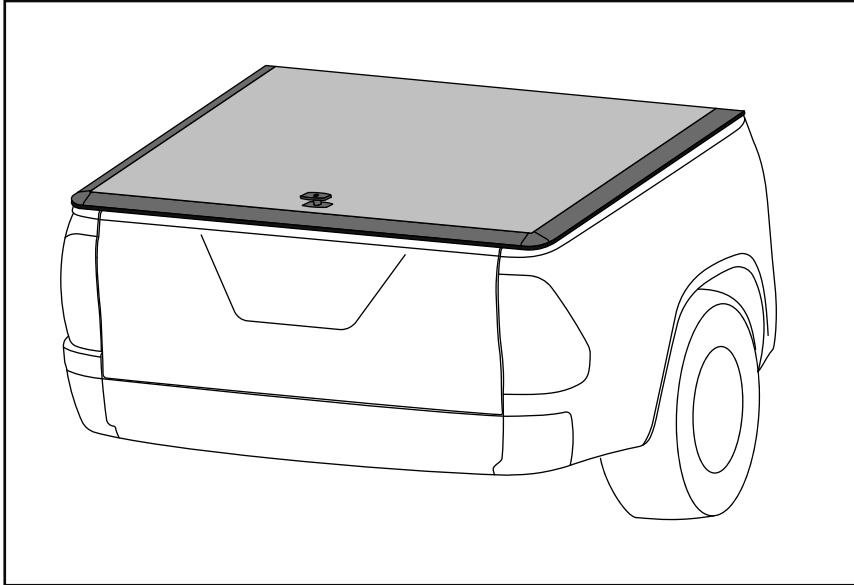
**Step 25 (Optional)**

Required tools: Rivet gun.

- Ensure all the parts are correctly installed.
- Open the tailgate.
- Close the cover slowly and ensure locking mechanism functions correctly. Repeat ten times.
- Fully open the cover.
- Close the cover again slowly ensuring the tailgate lock brackets are lined up correctly (if installed) and the cover closes fully.

Note: Ensure the keys do not get locked inside the tub.