

Fitting

INSTRUCTIONS



PRODUCT	Nosecone Protector		 20 MIN
APPLICATION	Toyota Kluger - 2021		
PART NO	HG-PPCK-TOY-KLUGER-21	DATE –	29 MARCH 2022

VERY IMPORTANT

- PLEASE READ THESE INSTRUCTIONS CAREFULLY BEFORE COMMENCING WITH FITMENT.
- ENSURE EACH STEP IS CHECKED AND TICKED OFF BEFORE MOVING ON TO THE NEXT STEP.

KIT CONTENTS

Item	Qty	Description	Item	Qty	Description
A	1	Nosecone Protector	F	8	Neoprene Washer (Thick)
B	4	Top Fixed Metal Clip	G	8	Large Abrasion Resistant Tape
C	4	Lower Metal Clip	H	2	Small Abrasion Resistant Tape
D	8	Screw	I	1	Alcohol Wipe
E	8	Fibre Washer (Thin)			



A

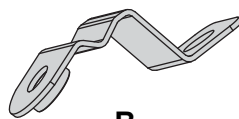

B

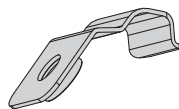

C



D



E



F

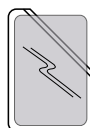

G



H



I

REQUIRED TO FIT

- 1x Bucket with soapy water mix
- 1x Phillips Head Screw Driver
- 1x Trim Removal Tool

- 1x Pencil or Non-permanent Marker
- 1x Long Nose Pliers

PRECAUTIONS

Ensure that you adequately cover and protect Seats, Carpets, Body parts as well as Door entry areas with non-scratch covers, before installation. Ensure that your workmanship is of the highest professional standard and that you do not scratch or damage the vehicle or accessory to be fitted.

Before commencing with fitment, carefully unwrap the product and ensure that the kit is complete and that the part is free of damage.

INSTALLATION PROCEDURE

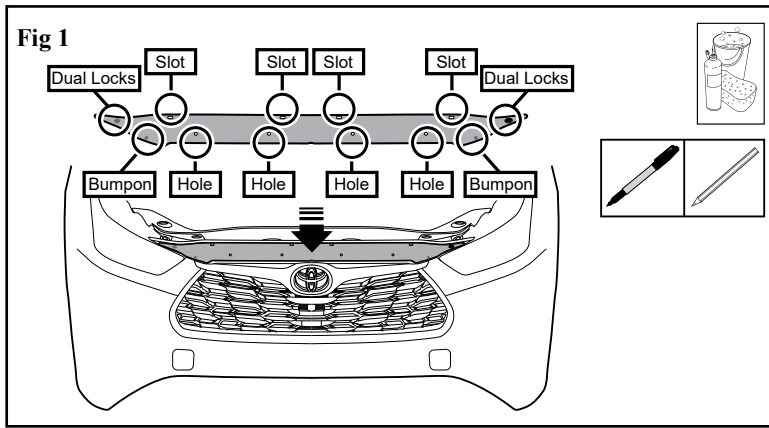

Read installation instructions thoroughly before commencing installation.

Open and thoroughly clean and dry the nosecone.

Trial fit the nosecone protector centrally onto the nosecone.

Note and mark where the slots and holes correspond to the nosecone and the lower fascia.

Also note and mark where the two small bumpons and the two outer dual locks contact the nosecone surface.

Remove the Nosecone Protector.

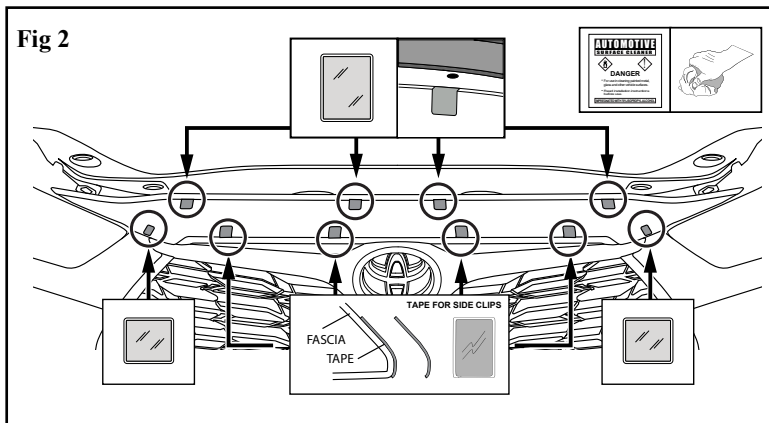

Clean the eight previously noted clip positions and the two bumpon positions with the alcohol wipe provided.

Wipe off any residue with a clean, dry cloth.

Adhere the large abrasion resistant tape strips to the front of the fascia at the clip positions and the small abrasive resistant tapes to the each bumpon position.

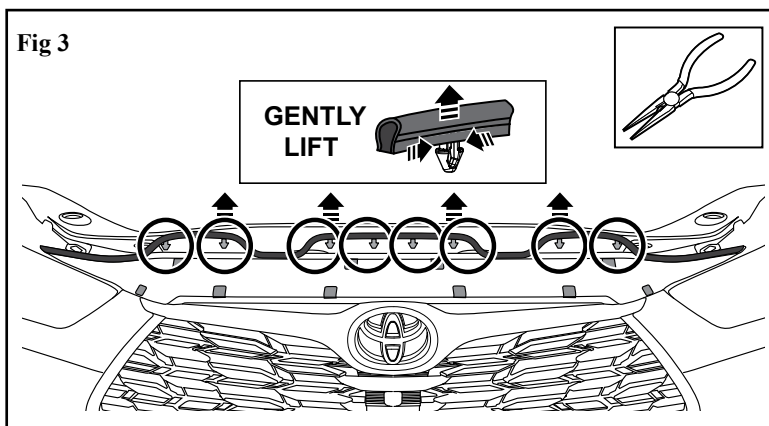

Gently pry up the scrivets in the seal at each top clip location.

Take care not to damage the scrivets. Needle-nose pliers may be needed to ensure the scrivets are lifted evenly and not damaged or distorted. Apply pressure inward with the pliers to release the clip.

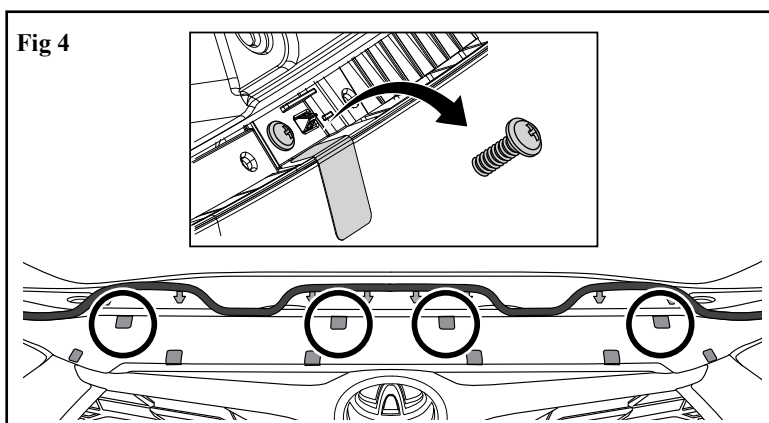

Remove the screws at the four top clip positions in the vehicle and retain.

INSTALLATION PROCEDURE

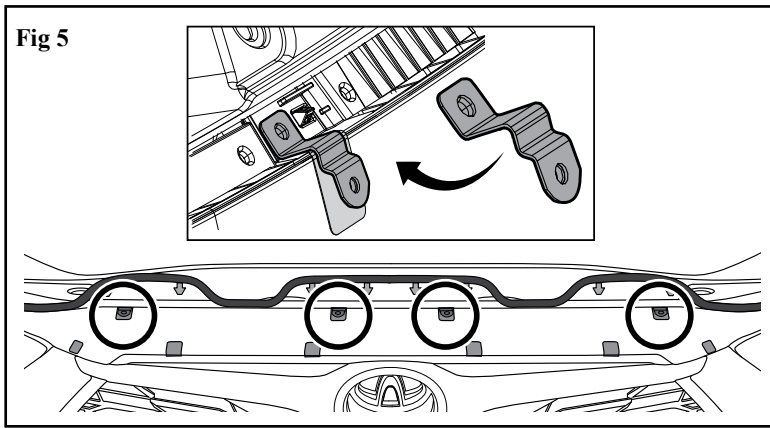

Install a Top Metal Clip at the four top clip positions and align the hole in the clip with the vacant screw hole in the vehicle.

Ensure that the clips are positioned over anti-abrasive tape and do not come into contact with any of the nosecone's paint work. Failure to do so may result in permanent paint damage.

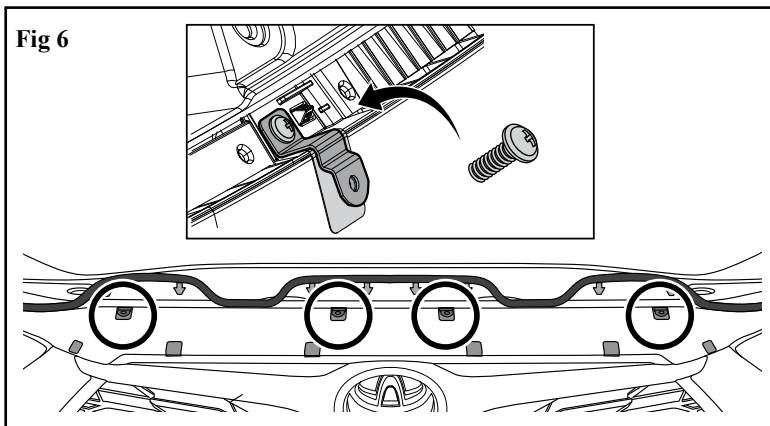

Re-install the retained screws through the Top Metal Clips, securing them to the vehicle.

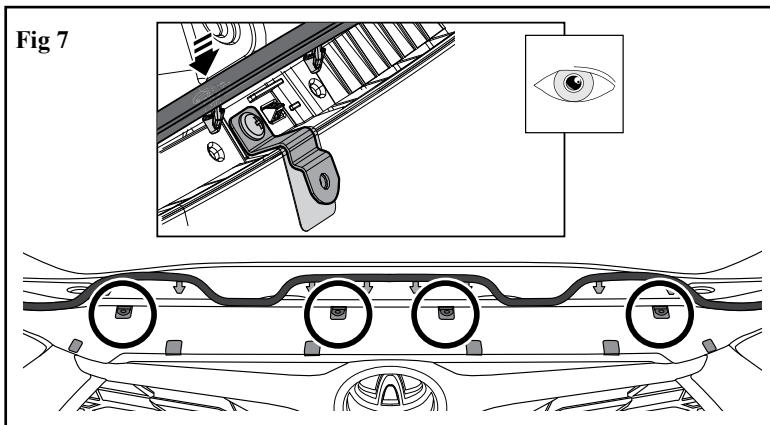

Re-install the seal by pushing the scrivets in the seal into the holes in the vehicle.

Ensure that the plugs are fully clipped into the hole and check by pulling upward to ensure they are fully engaged and do not come out.

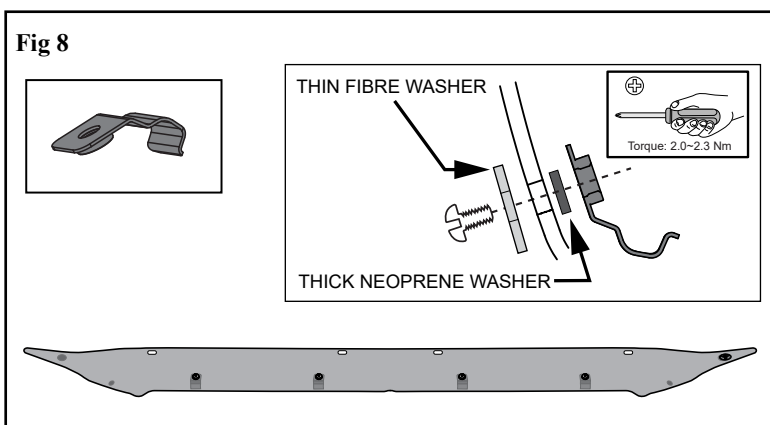

Secure the Nosecone Protector to the four lower metal clips with the small screws, fibre and neoprene washers.

The neoprene washers go in between the Nosecone Protector and the Metal clips.

INSTALLATION PROCEDURE

Fig 9

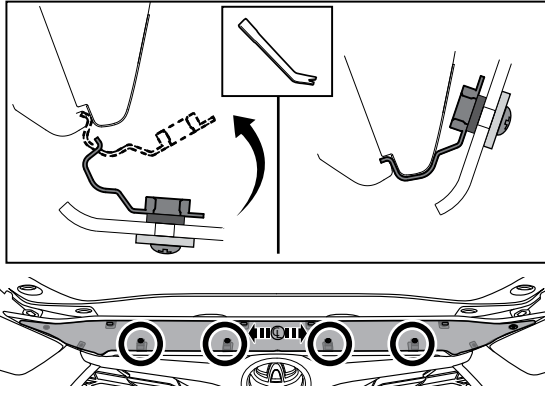

Using a trim tool, pry open a gap between the nosecone and fascia, and centrally install the Nosecone Protector by inserting the four attached lower metal clips into the gap as shown.

Ensure that the clips are positioned over anti-abrasive tape and do not come into contact with any of the nosecone's paint work. Failure to do so may result in permanent paint damage.

Fig 10

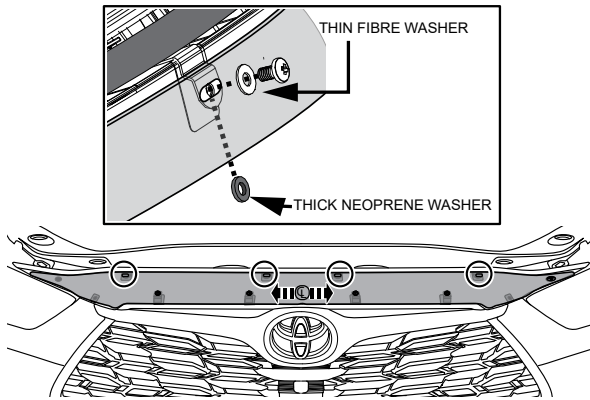

Loosely secure the Nosecone Protector to the four top metal clips with the small screws, fibre and neoprene washers.

The neoprene washers go in between the Nosecone Protector and the Metal clips.

Check the Nosecone Protector is sitting centrally on the nosecone. Tighten the top screws.

When tightening the wing clips ensure they do not rotate on the nosecone in order to prevent damage to the vehicle when the bonnet closes.

Fig 11

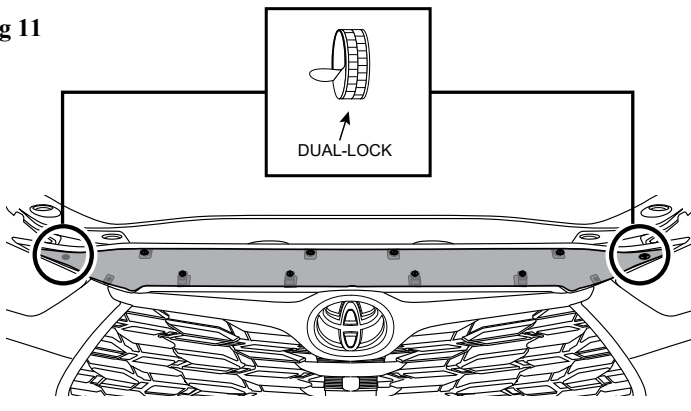

At the dual-lock disc location slightly lift the Nosecone Protector, and remove the dual-lock disc backing tape.

Apply firm downward pressure to the dual lock disc to ensure that it adheres to the Nosecone.

To Remove Nosecone Protector:

Reverse the above procedures.

Care Instructions:



Clean with a mild detergent and water solution.



Do not use automatic car wash.



Do not use abrasive cleaners.