

Fitting

INSTRUCTIONS



PRODUCT	HEADLIGHT PROTECTOR	20 MIN
APPLICATION	Toyota Rav4 - 2019	
PART NO	HLP-PPCK-TOY-RAV4-19	DATE – 23 FEBRUARY 2022

VERY IMPORTANT

- PLEASE READ THESE INSTRUCTIONS CAREFULLY BEFORE COMMENCING WITH FITMENT.
- ENSURE EACH STEP IS CHECKED AND TICKED OFF BEFORE MOVING ON TO THE NEXT STEP.

KIT CONTENTS

Item	Qty	Description	Item	Qty	Description
A	1	Headlight Protector "RHS"	F	2	Bottom Metal Clip Outer
B	1	Headlight Protector "LHS"	G	8	Washer
C	2	Top Metal Clip	H	8	Screw
D	2	Side Metal Grille Clip	I	8	Anti-Abrasive Tape
E	2	Bottom Metal Clip Inner	J	1	Alcohol Wipe

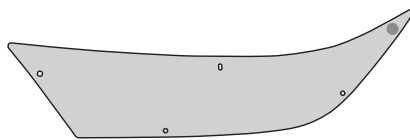

A

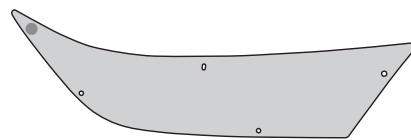

B

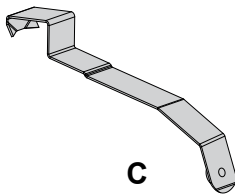

C

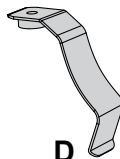

D

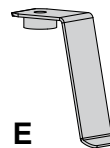

E

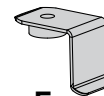

F



G



H



I



J

REQUIRED TO FIT

1x Bucket with soapy water mix

1x Pencil or non-permanent Marker

PRECAUTIONS

Ensure that you adequately cover and protect Seats, Carpets, Body parts as well as Door entry areas with non-scratch covers, before installation. Ensure that your workmanship is of the highest professional standard and that you do not scratch or damage the vehicle or accessory to be fitted.

Before commencing with fitment, carefully unwrap the product and ensure that the kit is complete and that the part is free of damage.

INSTALLATION PROCEDURE

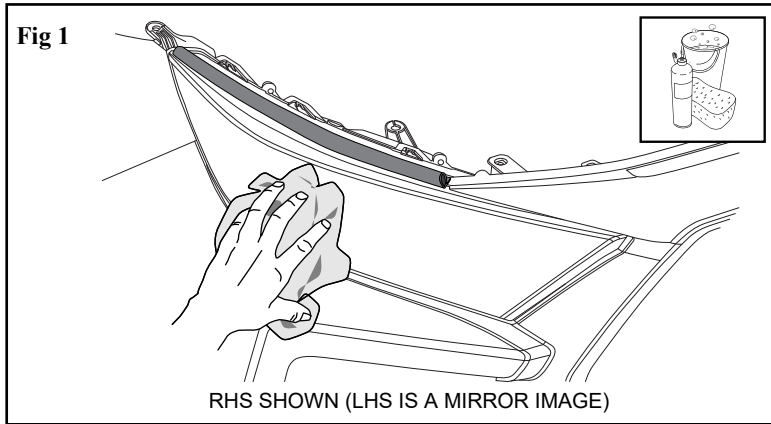

Read installation instructions thoroughly before commencing installation.

Thoroughly clean and dry the headlights and surrounding areas, on both the LHS and RHS.

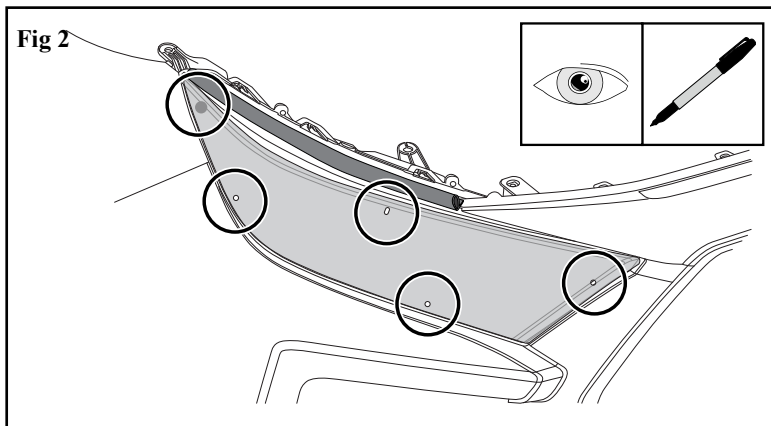

Trial fit the Headlamp Cover centrally on the headlamp.

Note the slot at the top of the Headlamp Cover and mark this location onto the headlamp assembly.

Note the holes at the bottom and side of the Headlamp Cover and mark these locations onto the headlamp assembly, bumper and grille directly below the holes.

Also note the dual-lock disc attached to the Headlight Protector and where it corresponds to the headlight.

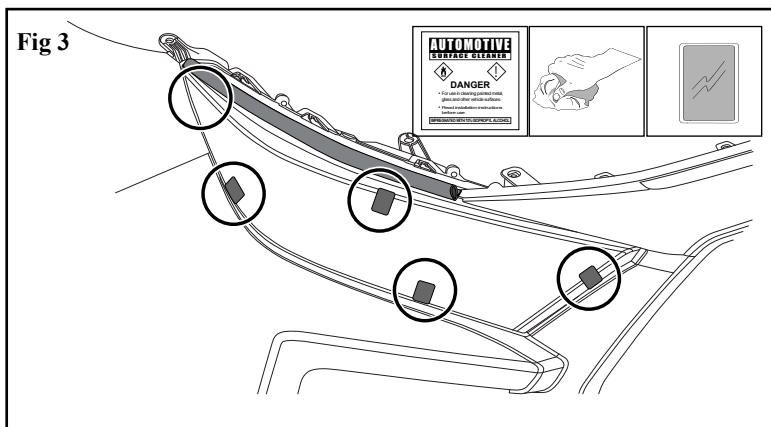

At the previously noted and marked tape and dual-lock locations, clean the headlamp lens with the alcohol wipe provided. Remove any residue with a clean dry cloth.

Fit the Headlamp Cover centrally on the headlamp, holding it approximately 1-2cm off the headlamp surface.

Adhere the anti-abrasive tapes provided to all slot and hole positions. Approximately two thirds of the anti-abrasive tape should be on the headlight surface.

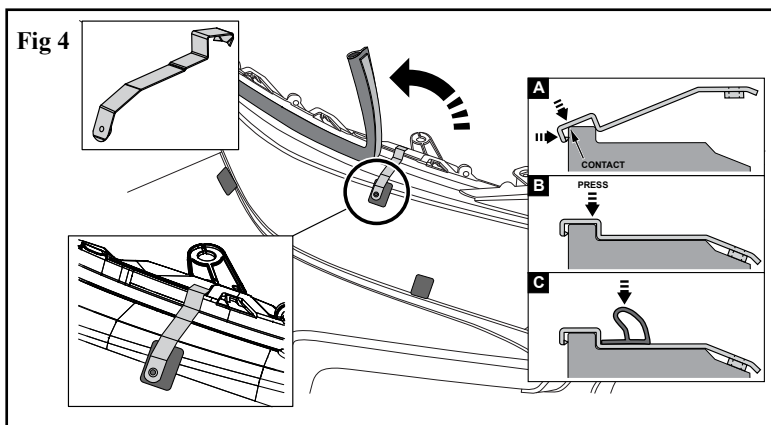

At the previously noted and marked top slot position, lift up the rubber seal and fit the top metal clip to the top of the headlamp.

- A. Install the clip at an angle and engage the barbs.
- B. Press the rear of the clip down flat.
You will hear a "snap" when the clip is installed correctly.
- C. Press the seal back down over the clip.

Check:

- the clip is flat to the headlamp top profile.
- the barb of the clip is engaged to the lamp bucket.
- the metal clip is located on the anti-abrasive tape and not on the headlamp lens.
- the seal sits flat over the clip

INSTALLATION PROCEDURE

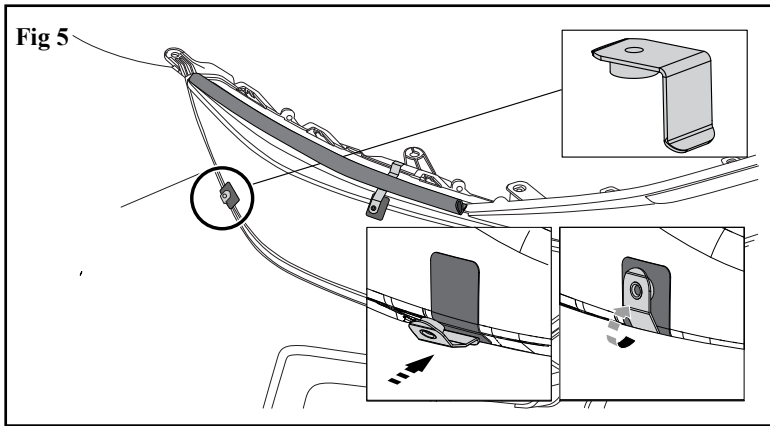

At the previously noted and marked bottom outer hole position, fit the bottom metal clip outer between the bumper and headlamp assembly.

Ensure that the metal clip is located on the anti-abrasive tape and not on the headlamp lens.

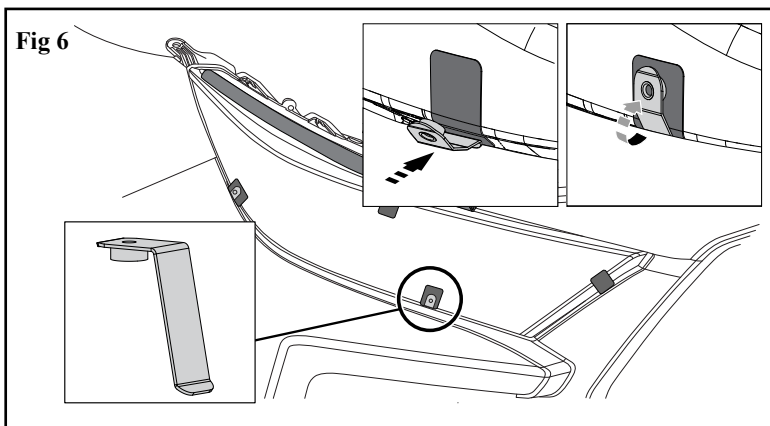

At the previously noted and marked bottom inner hole position, fit the bottom metal clip inner between the bumper and headlamp assembly.

Ensure that the metal clip is located on the anti-abrasive tape and not on the headlamp lens.

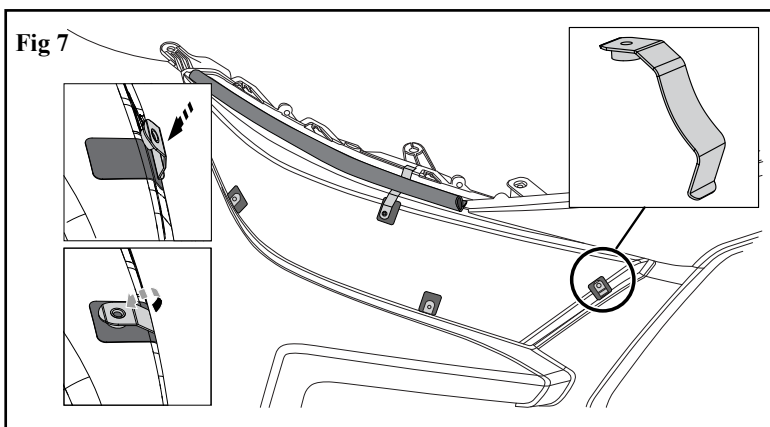

At the previously noted and marked side hole position, fit the side metal grille clip between the grille and the headlamp assembly.

Ensure that the metal clip is located on the anti-abrasive tape and not on the headlamp lens.

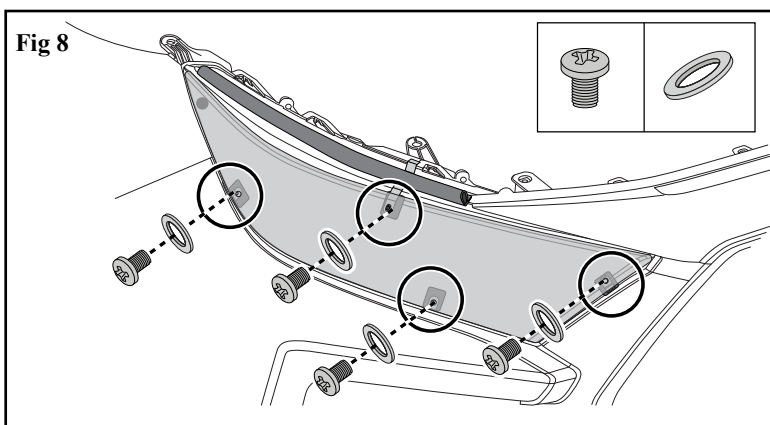

Loosely secure the Headlamp Cover to the metal clips with the screws and washers provided.

INSTALLATION PROCEDURE

Fig 9

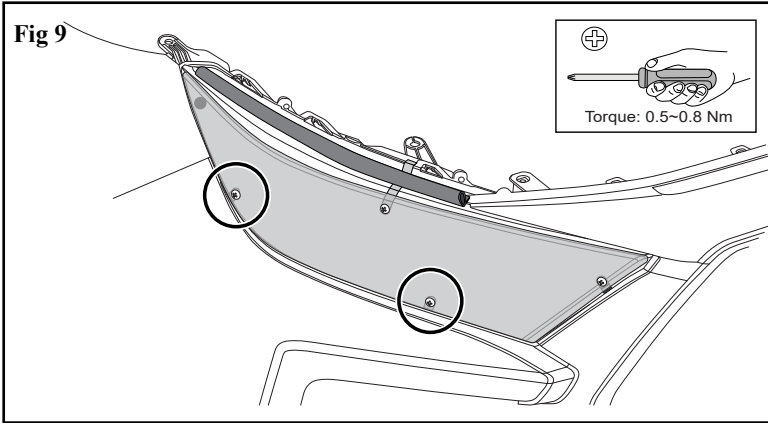

Tighten the two bottom screws to the specified torque setting.

Note: Ensure torque setting 0.5~0.8Nm is used.

Fig 10

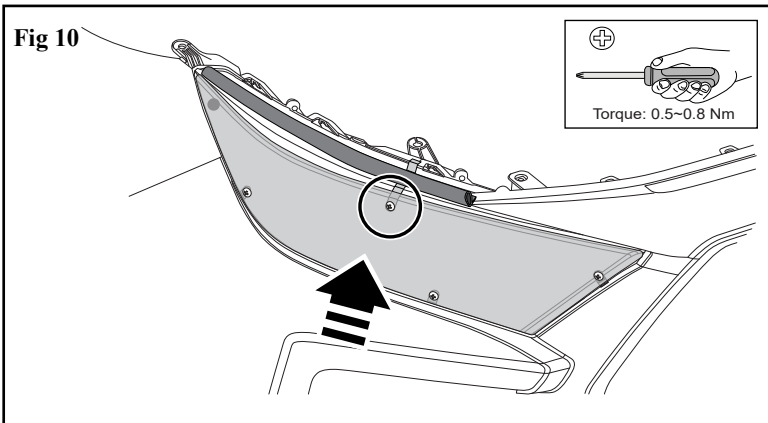

Tighten the screw at the top metal clip location to the specified torque setting, while applying upwards pressure to the Headlamp Cover.

Note: Ensure torque setting 0.5~0.8Nm is used.

Fig 11

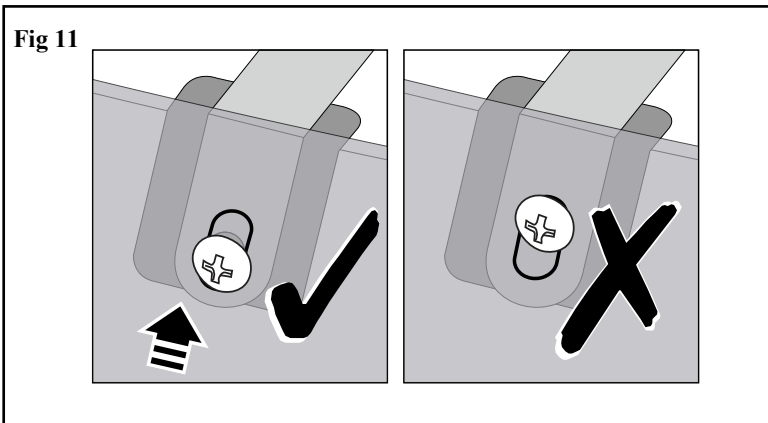

Ensure the top clip screw is as close to the bottom of the vertical Headlight Protector slot as possible.

Fig 12

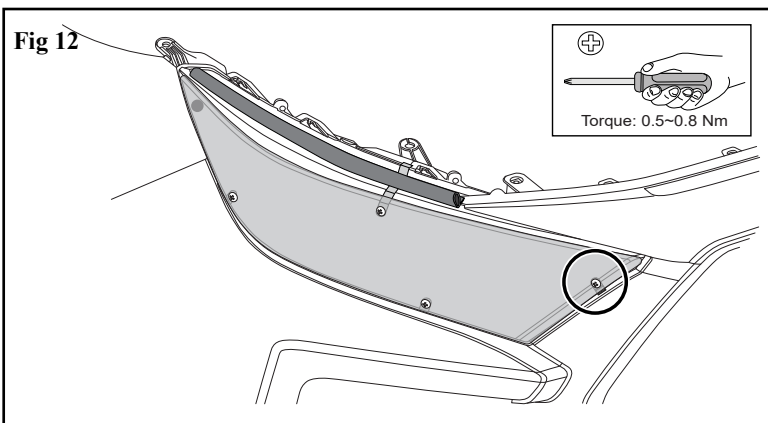

Tighten the side screw to the specified torque setting.

Note: Ensure torque setting 0.5~0.8Nm is used.

INSTALLATION PROCEDURE

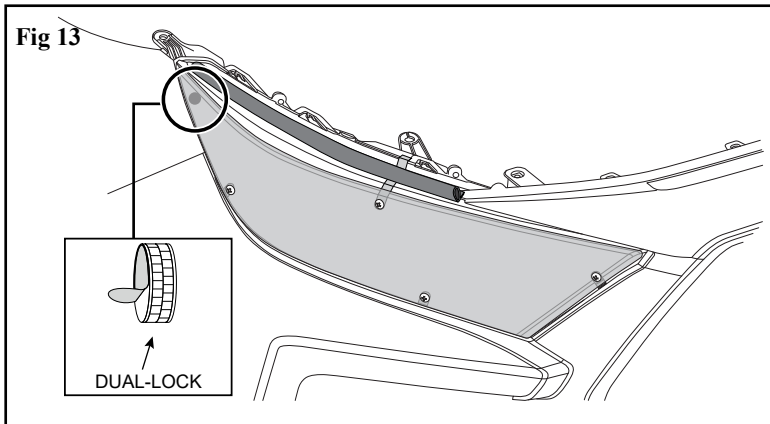

At the dual-lock disc location slightly lift the Headlight Protector, and remove the dual-lock disc backing tape.

Apply firm downward pressure to the dual-lock disc to ensure that it adheres to the Headlight lens.

Re-check that your workmanship has been of the highest professional standard, then clean up the work area and ensure that the vehicle or accessory is not scratched or left dirty. Remove all tools, protective covers, waste materials, grease, dirt or grime from the work area.

Care Instructions:



Clean with a mild detergent and water solution.



Do not use automatic car wash.



Do not use abrasive cleaners.