

INSTALLATION INSTRUCTIONS

EGR ROLLTRAC

ELECTRIC

Vehicle Model: MAZDA BT50 / ISUZU D-MAX
Year of manufacture: 2020 onwards

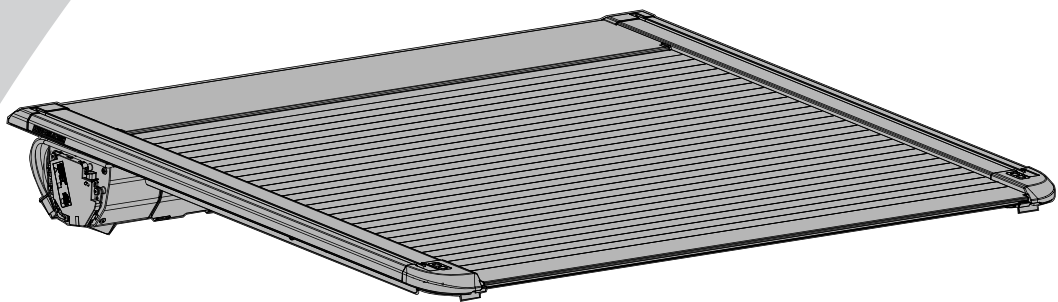

Installation time: 180 minutes (without tubliner)

Caution

- Do not attach EGR RollTrac in a location or by a method not specified.
- Do not use this product for any vehicle make or model, other than those specified in this document.
- Do not remove the plaque or label from this product.
- Do not modify the structure of the EGR RollTrac in any way.

General Notes

- Read through the fitting instructions before installation of EGR RollTrac.
- Always install the accessory following the fitting instructions. Failure to do so may cause damage to the vehicle or the accessory.
- Ensure all recyclable discarded vehicle accessory components and packaging are recycled following local recycling regulations.
- It is always recommended that this accessory is fitted by a qualified Technician.
- Safely store and protect any removed vehicle components.
- Ensure all bare metal surfaces are protected using Automotive Bare Metal Primer and touch-up paint.
- Remove all metal swarf and dust from all vehicle surfaces if surface is used for accessory installation.



Safety Notes

- Check that all work practices comply with safety standards.
- Please wear appropriate clothing and use safety equipment.



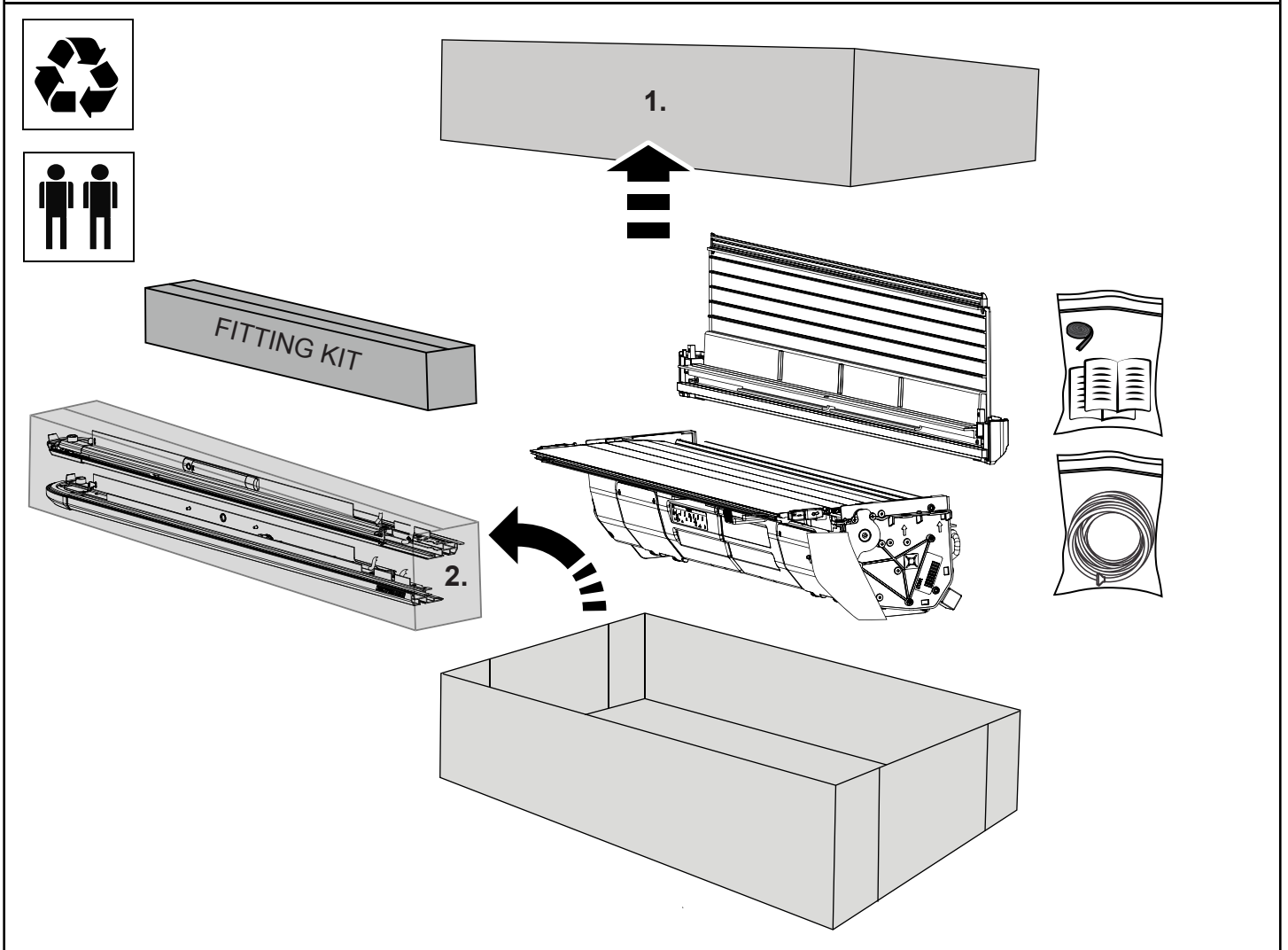
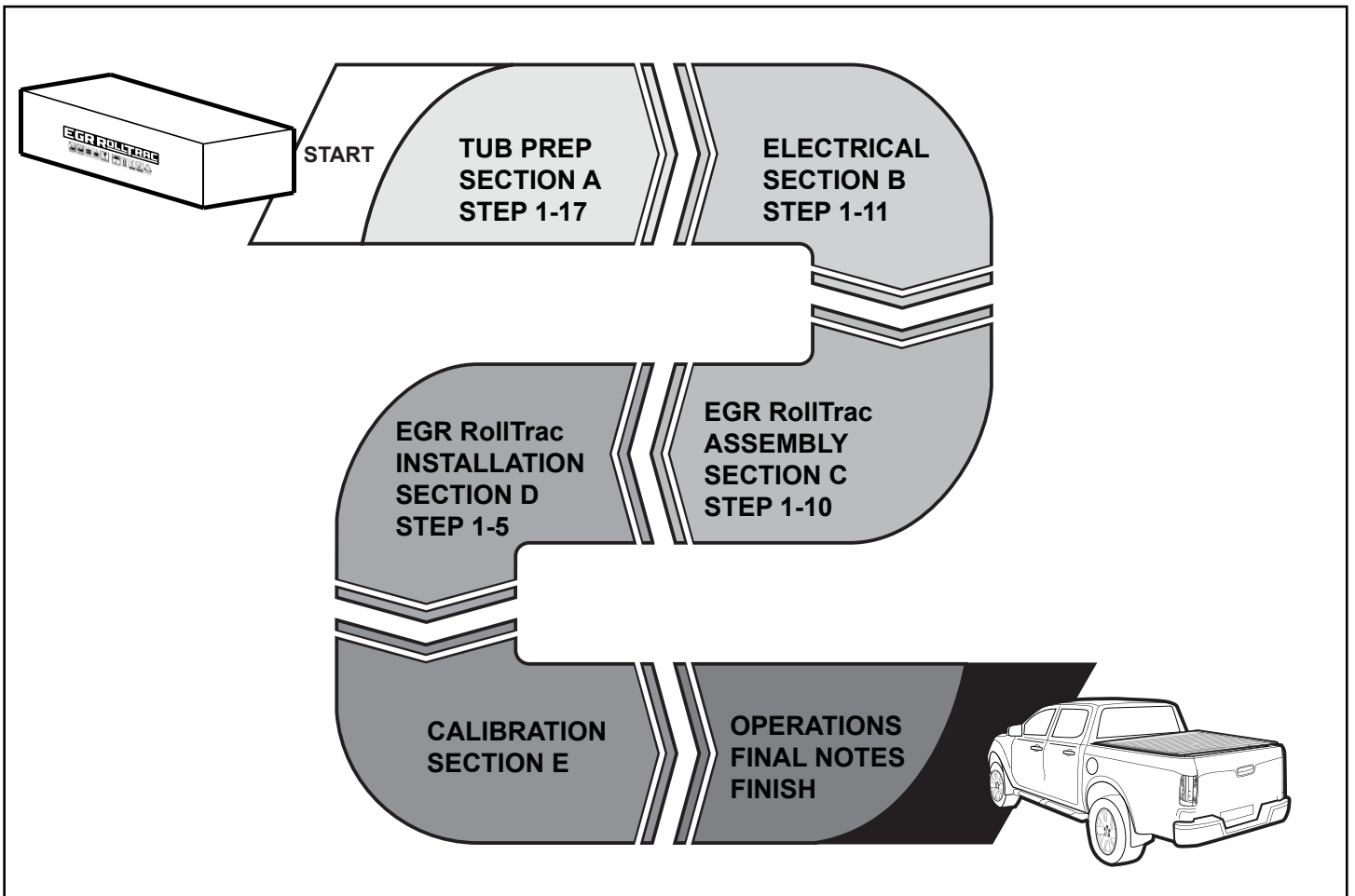

KIT CONTENTS - COMPONENT NUMBER AND QUANTITY

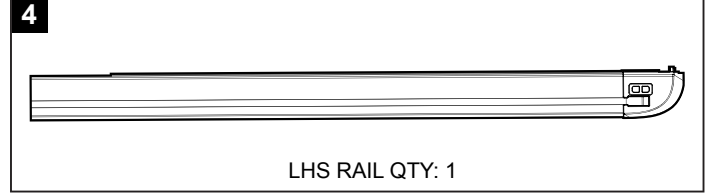
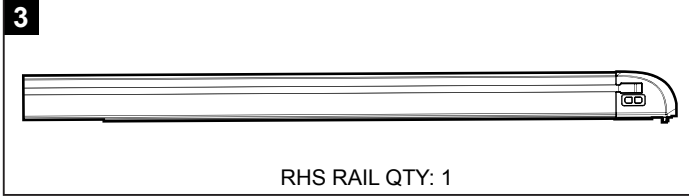
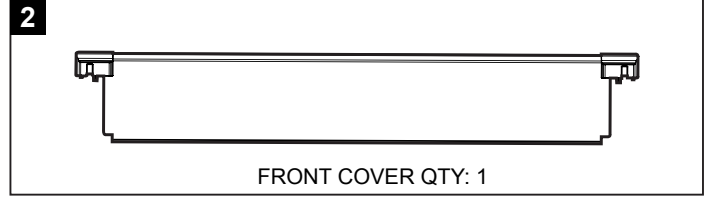
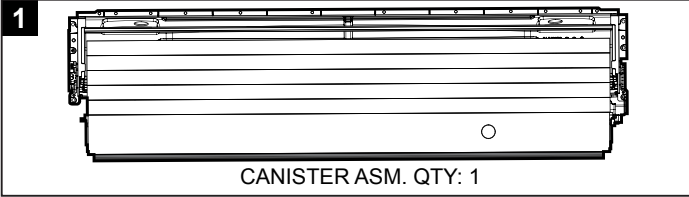

EGR ROLLTRAC FITTING KIT IN BOX

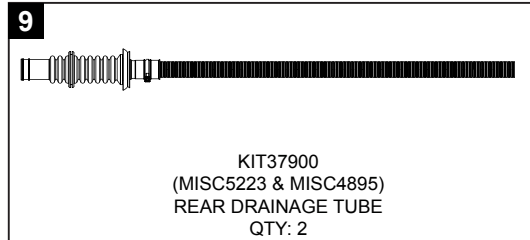
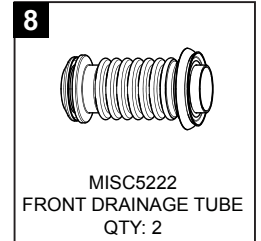
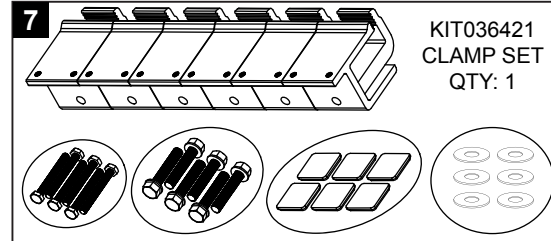
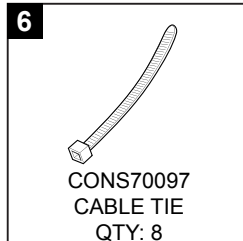
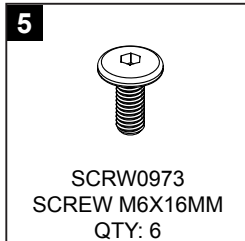

EGR ROLLTRAC FITTING KIT COMPONENTS IN BAGS

11 VEHICLE HARNESS LOOM0243

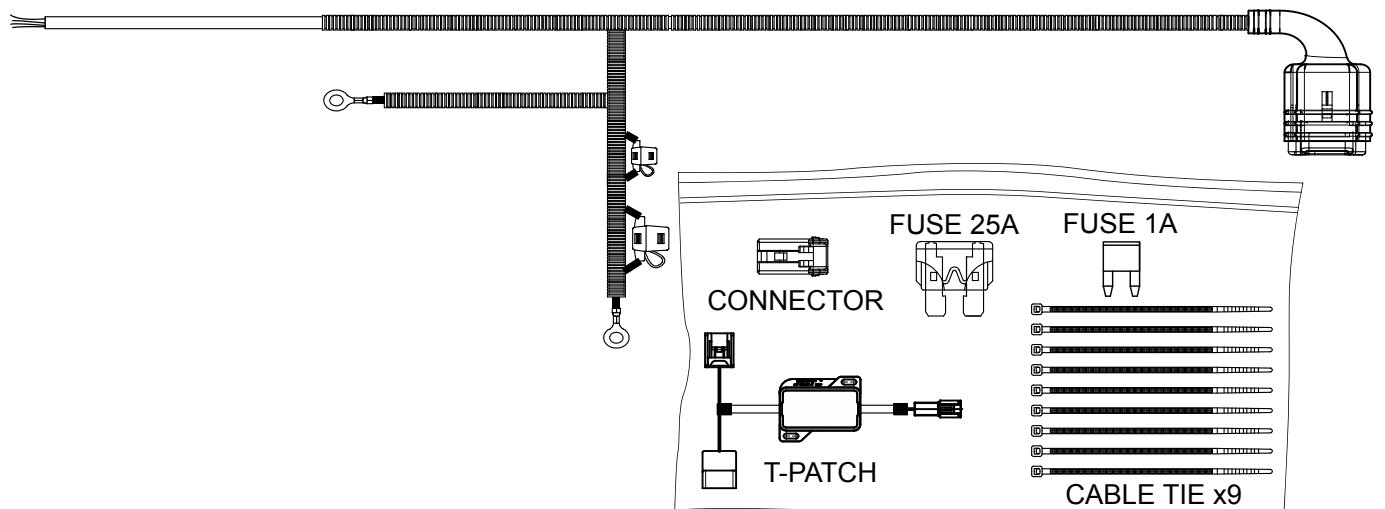

EGR ROLLTRAC FITTING KIT ADDITIONAL ITEMS

12 TAPE0698
TAPE 150X25MM
QTY: 6

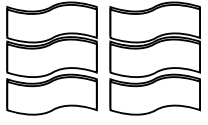

13 RUBBER
EXTRUSION
QTY: 2



14 EXTR0052

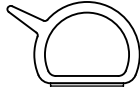

INSTALLATION
INSTRUCTIONS

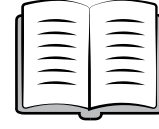

OWNERS
MANUAL



TUB REINFORCEMENT KIT

15 CLIP3952PC-LH
LOWER LH BRACKET
QTY: 1

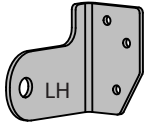

16 CLIP3952PC-RH
LOWER RH BRACKET
QTY: 1

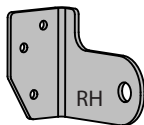

17 CLIP3951PC-LH
UPPER LH BRACKET
QTY: 1

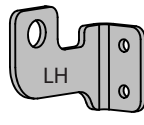

18 CLIP3951PC-RH
UPPER RH BRACKET
QTY: 1

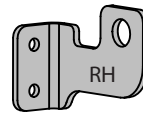

19 RIVET
FAST0634
QTY: 10

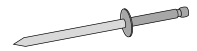

TOOLS REQUIRED - NOT SUPPLIED IN KIT

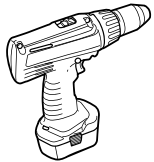

Drill



Holesaw
Ø29mm
Ø38mm

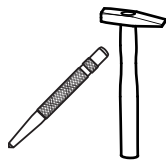

Centre Punch & Hammer



Drill Stop
Drill Bits
Ø2.0mm
Ø5.5mm
Ø9.0mm

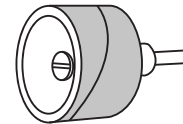

Bobbin Sander Ø60mm

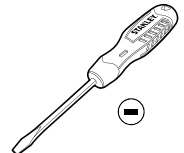

Flat Screwdriver

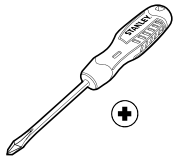

Phillips Screwdriver



Tape Measure



Scissors

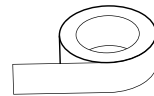

Masking Tape
Fiberglass Tape
Black Cloth Tape

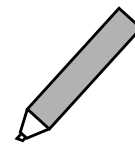

Non-permanent pen



Spanners 8,10,13mm

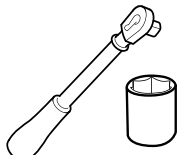

Ratchet & Sockets
7,10,13mm



Allen Key 4mm

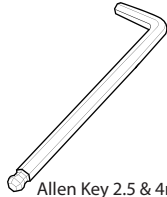

Allen Key 2.5 & 4mm

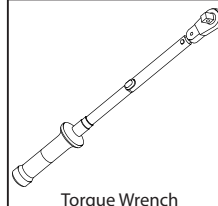

Torque Wrench



6mm File



Soapy Water



50/50
Isopropyl Alcohol/Water



Rust Inhibitor

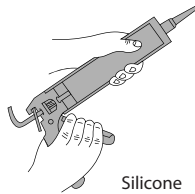

Silicone

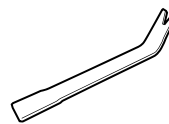

Trim Removal Tool

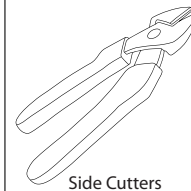

Side Cutters



Silicone Spray

Cutting device
needed to trim
tubliner

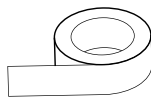

Anti-abrasion tape to seal
holes & slots

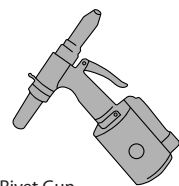

Rivet Gun

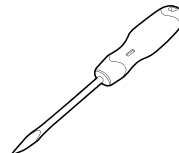

Grommet Piercing Tool

GLOSSARY:

- 1** Number inside a square indicate part number.
- 1** Number inside circle indicate the within a step.
- 1** Number inside the hexagon indicate torque instruction.

SECTION A

TUB PREPARATION

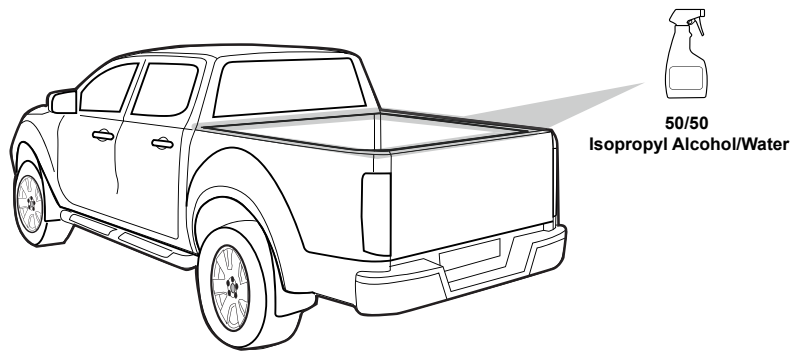
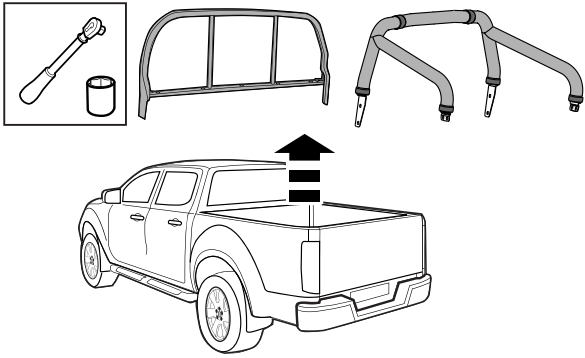

- 1 Carefully remove any accessories (Sports Bars, Cabin Guards, etc.) attached to the tub of the vehicle. Thoroughly wash the vehicle and tub and ensure that all dirt and grease is removed. Allow to dry. Clean the top surfaces of the tub and tailgate with a mixture of Isopropyl Alcohol and Water (50/50) and allow to dry.

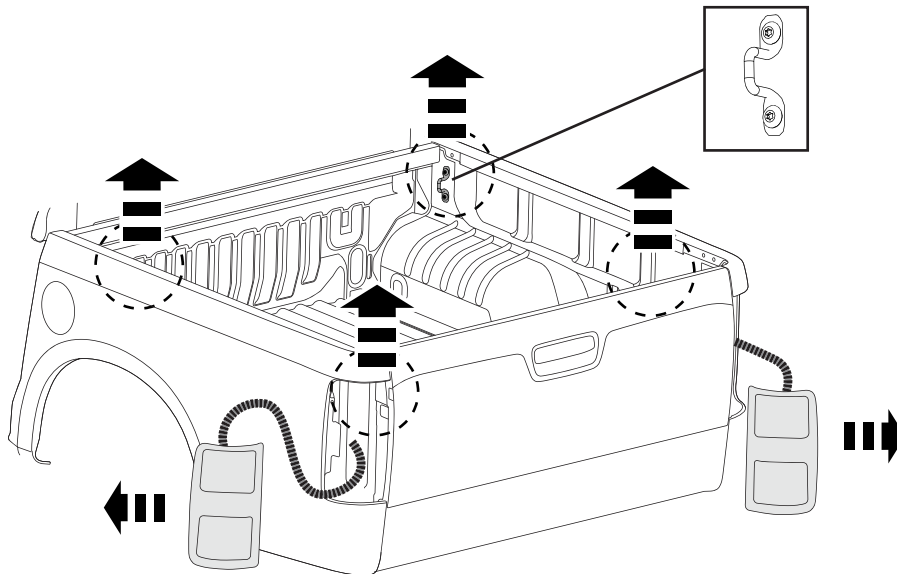

- 2 Carefully remove both Rear Tail Lamps with the appropriate tools and store in safe place. Retain all hardware for re-installation. Remove front and rear tie down hooks.

CONTINUE ON THE NEXT PAGE

TUB REINFORCEMENT KIT

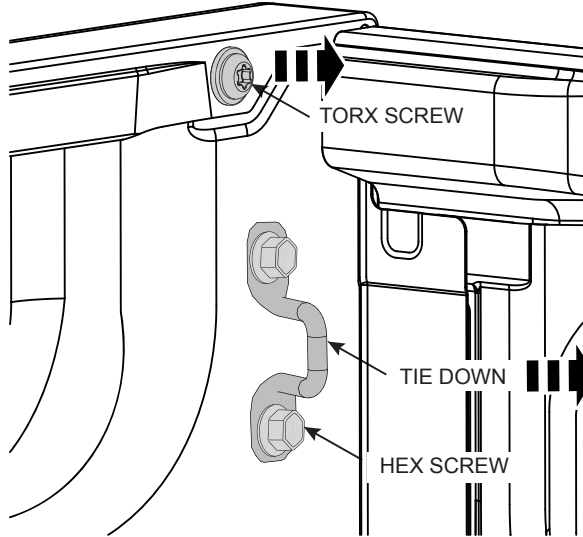
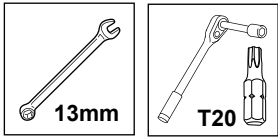

- 3** Remove the Torx screw from the tub front side rail (LHS shown). Remove the two hex screws holding the tie down hook and retain the Torx screw and both hex screw. Repeat for the RHS.

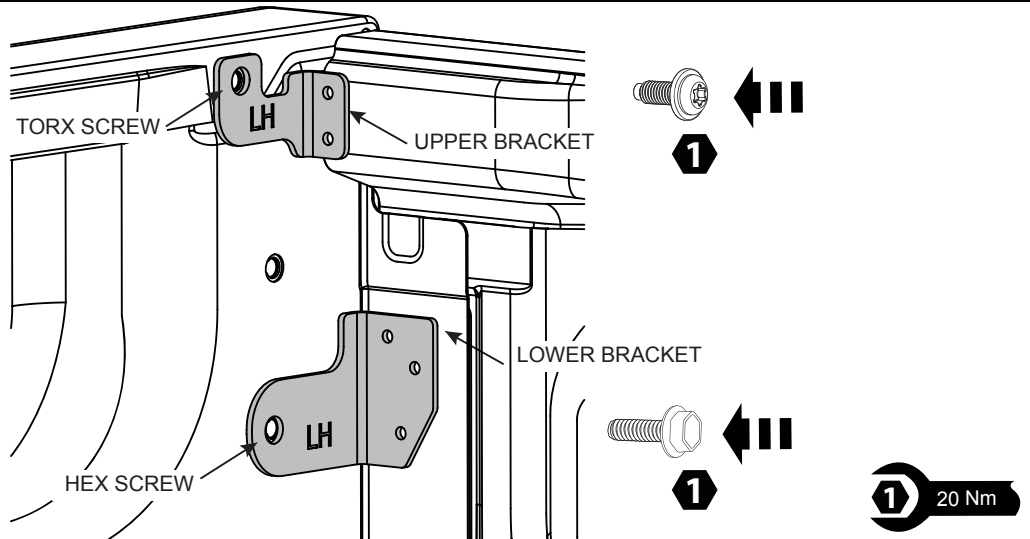
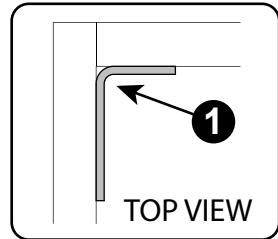
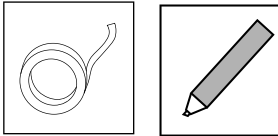
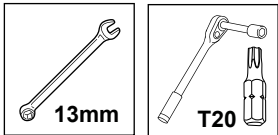

- 4** Cover the tub area under the brackets for marking purpose with masking tape and place the reinforcement plates in the LHS tub front corner as shown. Temporarily fix the brackets to the tub using the previously removed screws as shown. Ensure bracket is flush with tub (1). Mark the 5 holes centers using the brackets as a guide. Remove brackets. Repeat for the RHS.
 Note: Brackets must be mounted directly to the tub if a tubliner is fitted.

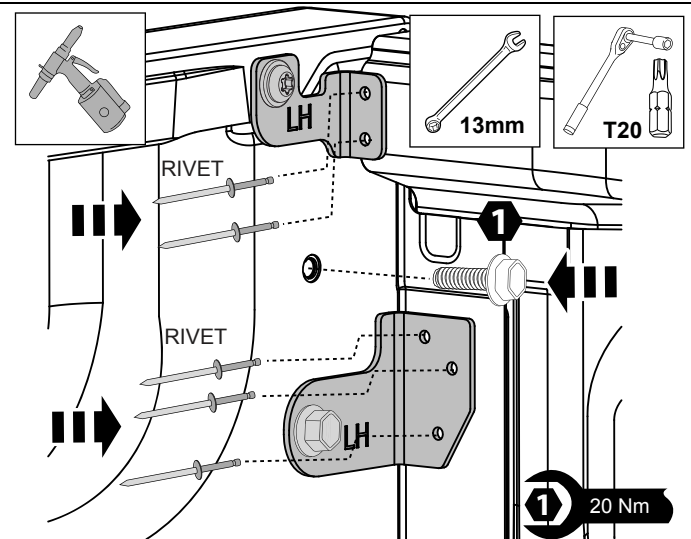
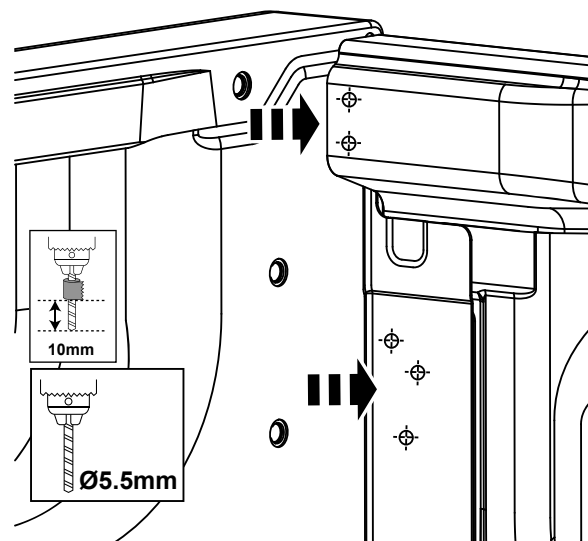

- 5** Drill the 5 hole location with 5.5mm drill bit set to 10mm depth. Apply rust inhibitor to the holes. Fit brackets using bolts and rivets as shown. Repeat for the RHS. Refit third bolt as shown.



Tub liner Trim Note:

Due to variations in tubliners it is strongly recommended that Installers mark up and pre check part fitment in assy and adjust trim lines prior to making final cuts. Mazda will not be held responsible for incorrect or inaccurate liner trimming.

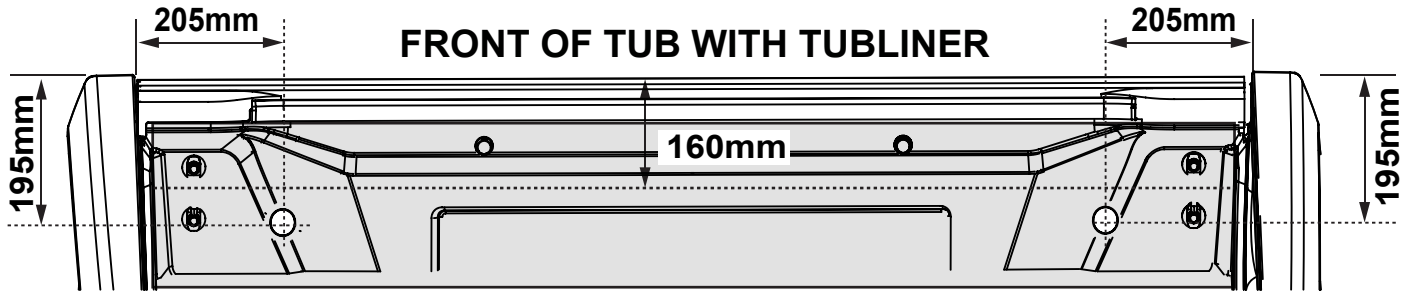
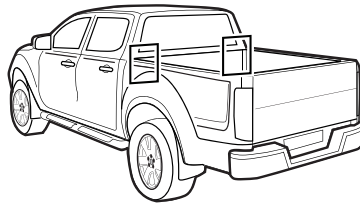
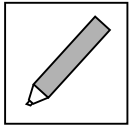
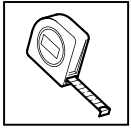

- 6** Measure and markup the positions for the Front Drain Tubes on both sides. Centre punch the locations and drill through the tub and tubliner (if fitted) with 5.5mm drill. Measure and mark 160mm from the top of the tub for the front of the tubliner trim.

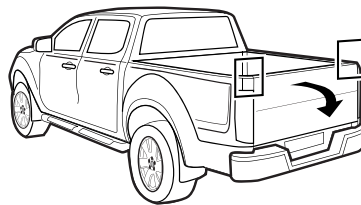
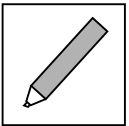
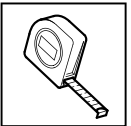

REAR OF TUB RHS WITH TUBLINER

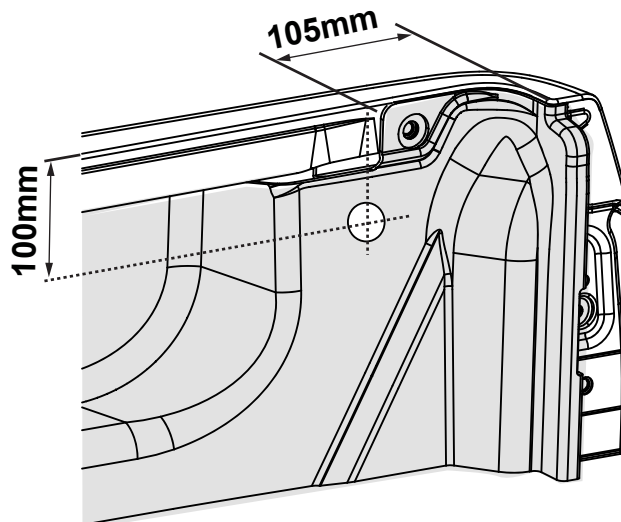

- 7** Fully open the tailgate and at the rear of the tub on both sides measure and markup the positions for the Rear Drain Tubes. Centre punch the locations and drill through the tub and tubliner (if fitted) with 5.5mm drill.

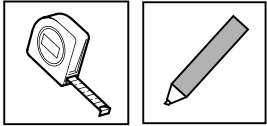

FRONT LHS OF TUB WITH TUBLINER

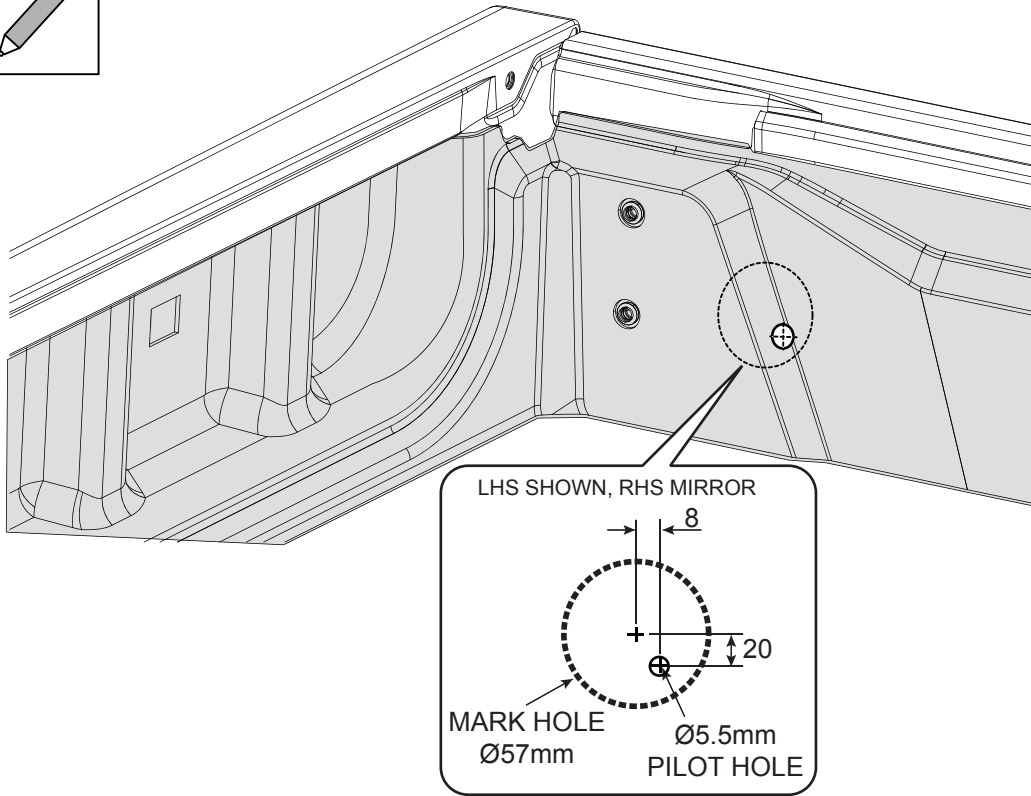

- 8** Mark the Ø57mm circle on the front of the tubliner (if fitted) using the measurements from the previously drilled pilot hole. Repeat for the RHS. Follow the markup in the next step.

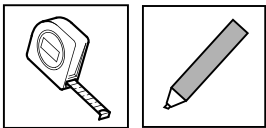

FRONT LHS OF TUB WITH TUBLINER

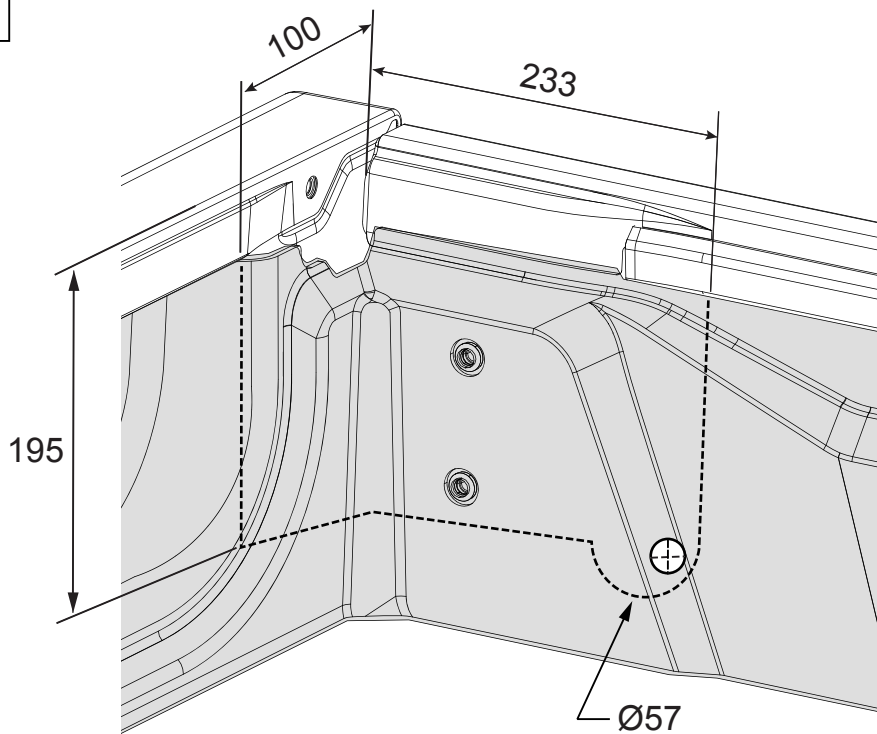

- 9** Mark the tubliner as shown above. Repeat for the RHS.

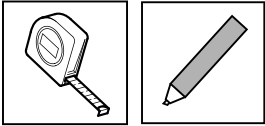

LHS OF TUB WITH TUBLINER

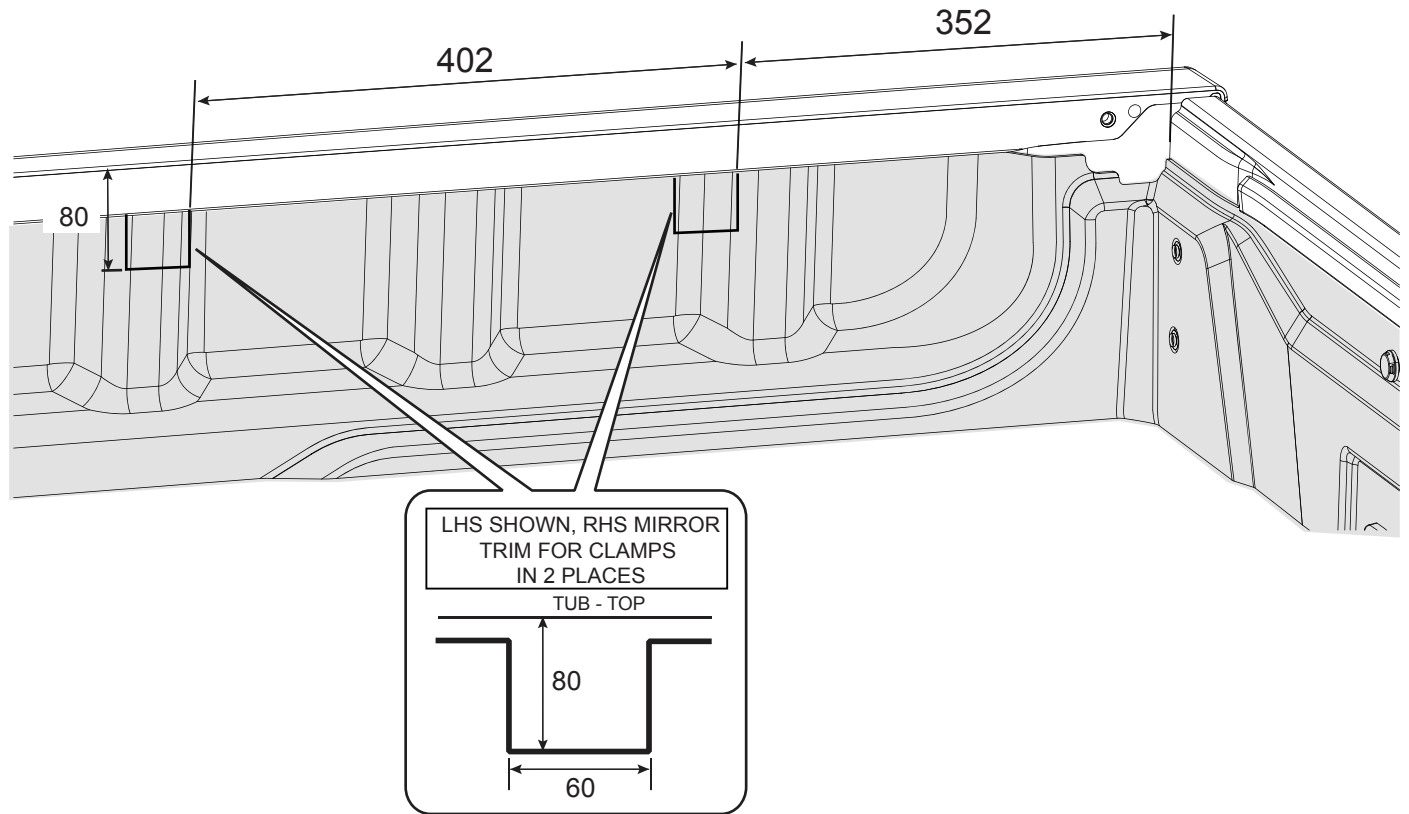

10 Mark the two locations on each side of the tubliner as shown above.

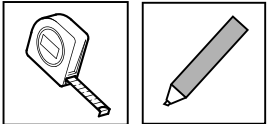

Cutting device
needed to trim
tubliner

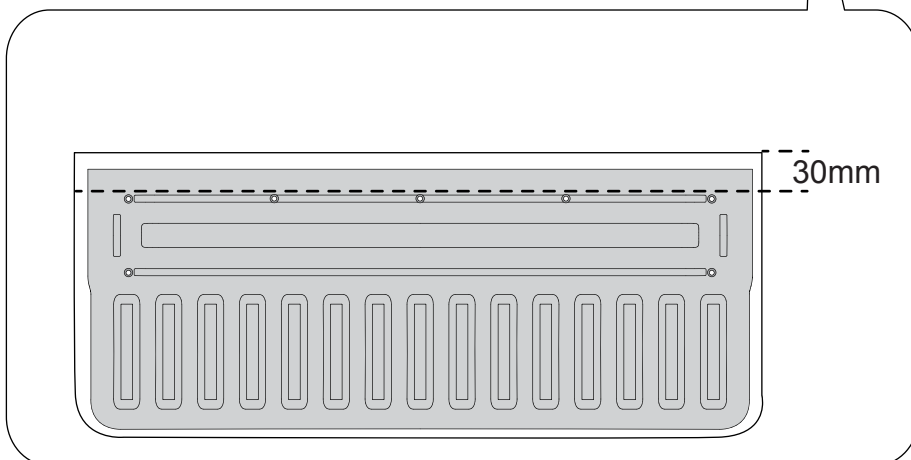
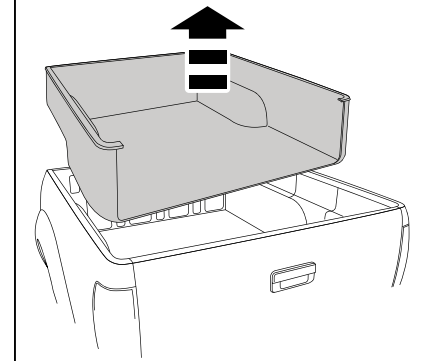
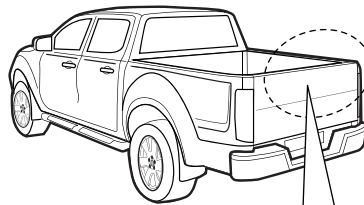

11 If tailgate liner is fitted, mark line as indicated the top of tailgate. Remove and trim along the line using cutting device. Remove tubliner.

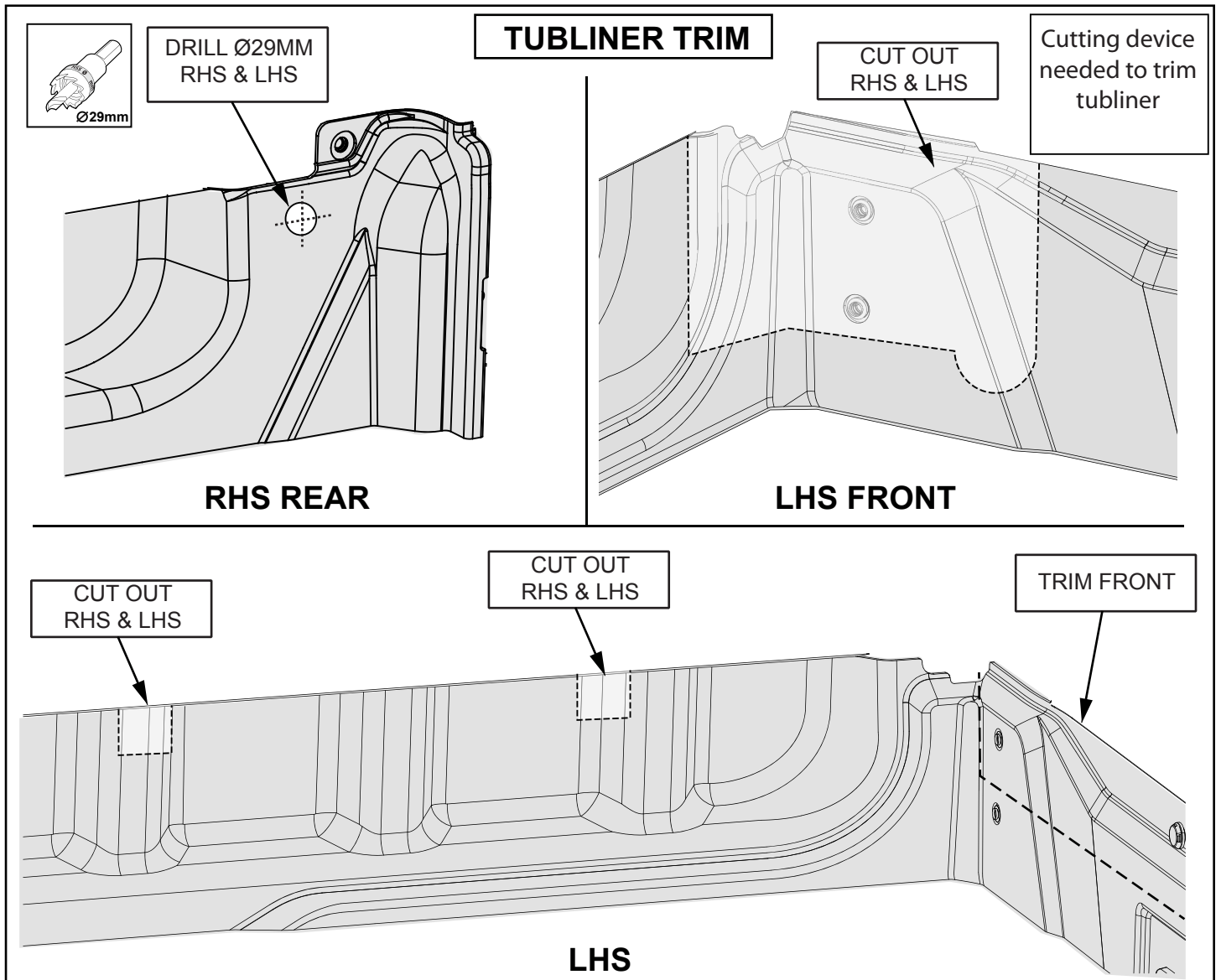

12 Drill holes and trim the tubliner as shown above using markings from previous steps. Clean sharp edges.

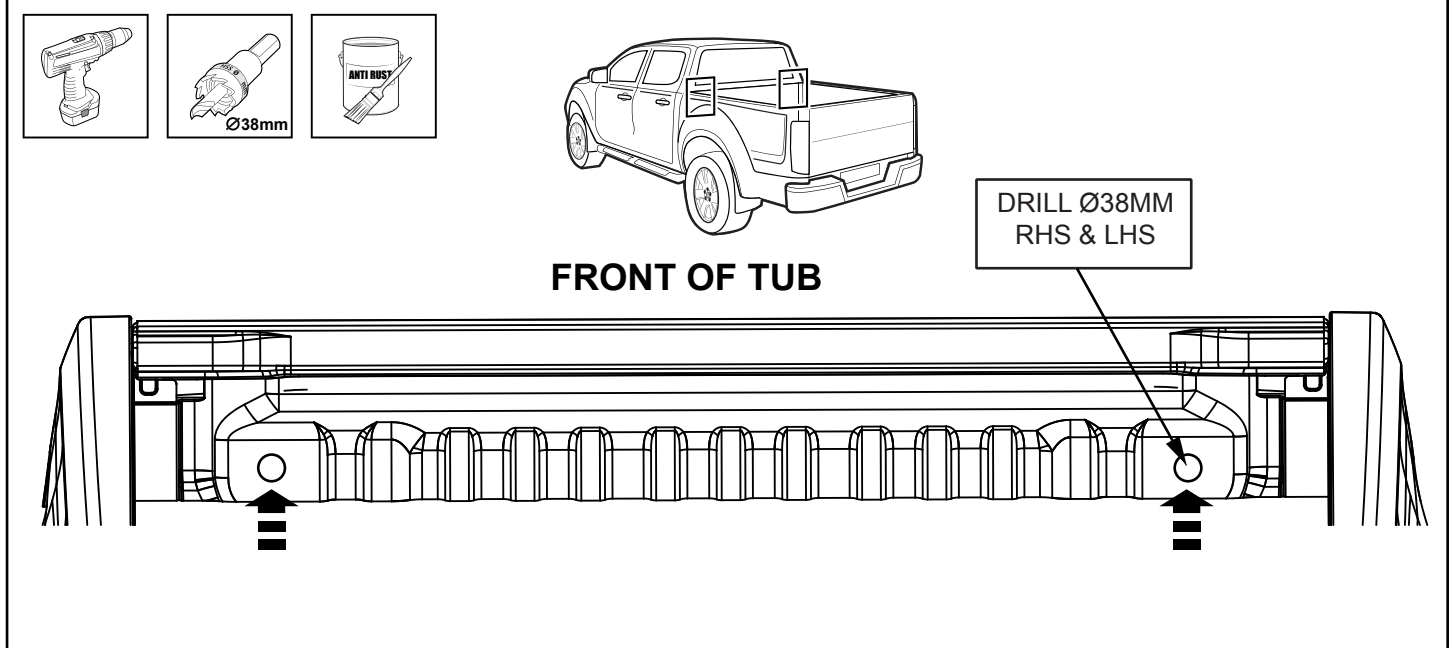

13 Drill out the pilot holes with 38mm hole saw. Clean all burrs and coat the exposed metal with a suitable rust preventative (not supplied).

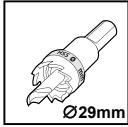
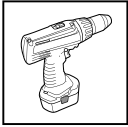

RHS REAR OF TUB

DRILL Ø29MM
RHS & LHS

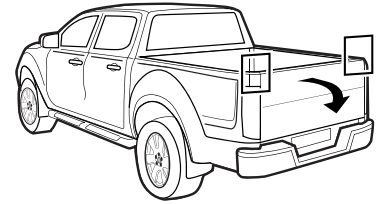
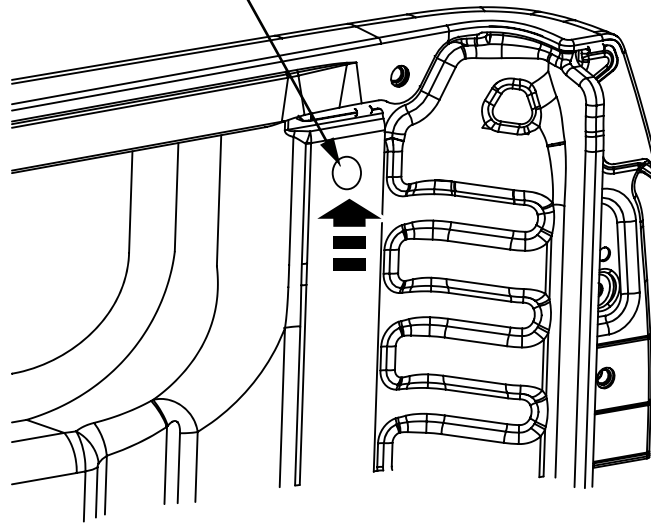

- 14** Fully open the tailgate and drill out the pilot holes with 29mm hole saw. Clean all burrs and coat the exposed metal with a suitable rust preventative (not supplied). Repeat for the LHS.

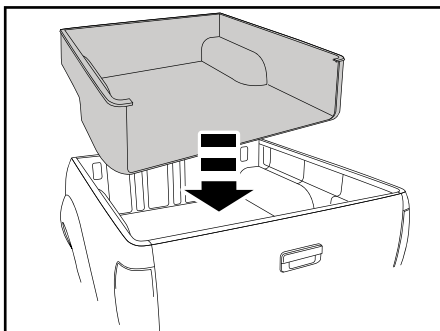
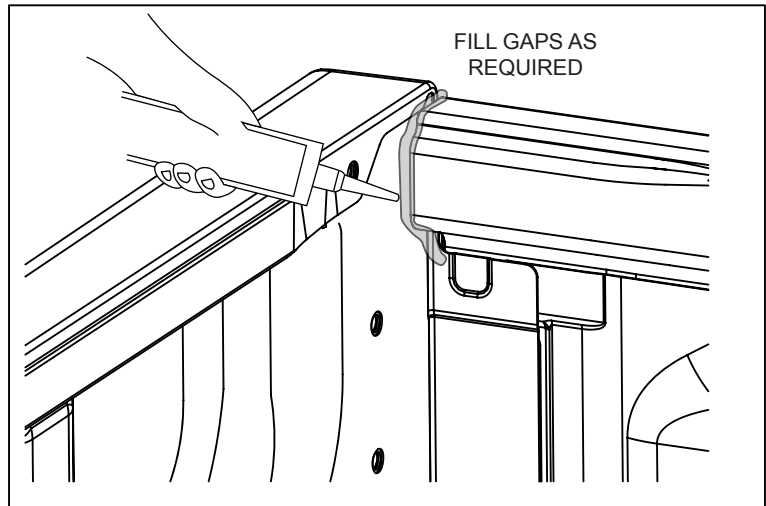
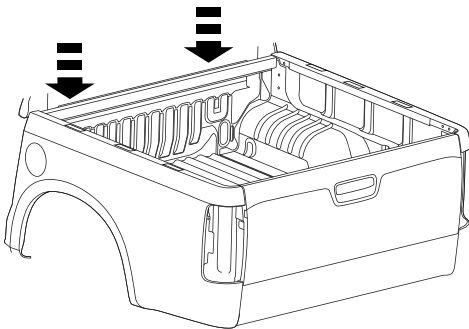
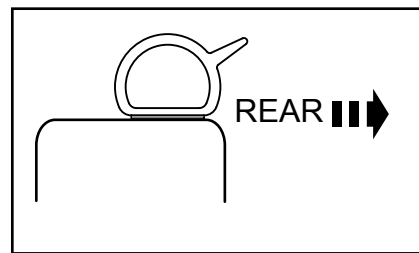
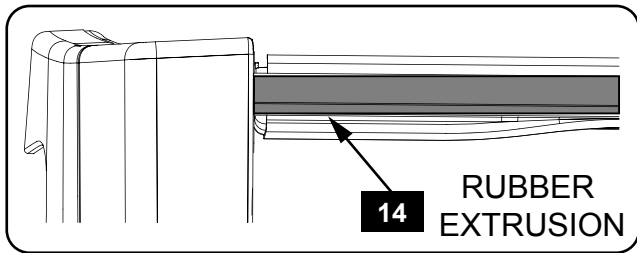

- 15** Clean top of the front tub rail and apply primer. Allow to dry. Apply rubber extrusion (14) to the top of tub rail as shown with the flap facing rearwards (see section view). To prevent water ingress, apply a bead of silicon (non-acetic) to gaps such as between the front rail and the side rail as shown. Holes in the tub from any removed accessories should be covered using tape or silicone. NOTE: Ensure the Silicone bead transitions smoothly between front and side rail and underneath the rubber extrusion. **Refit the tubliner.**

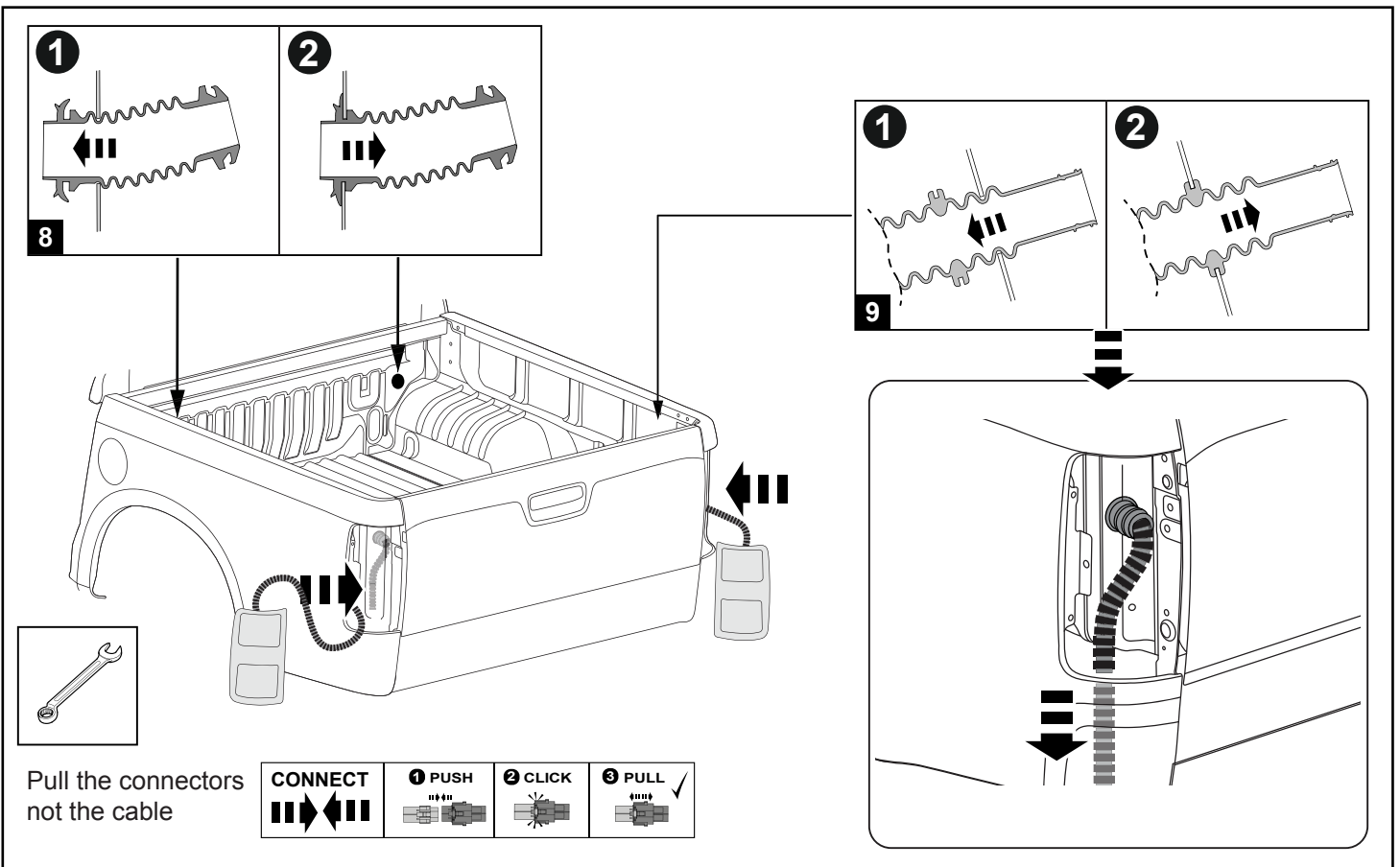

16 Install the front drain tubes (8) as shown. Install the rear drain tubes (9) and water conduit into the gap in the LHS and RHS tail lamp recess. Re-connect the rear tail lamps with the previously removed hardware.

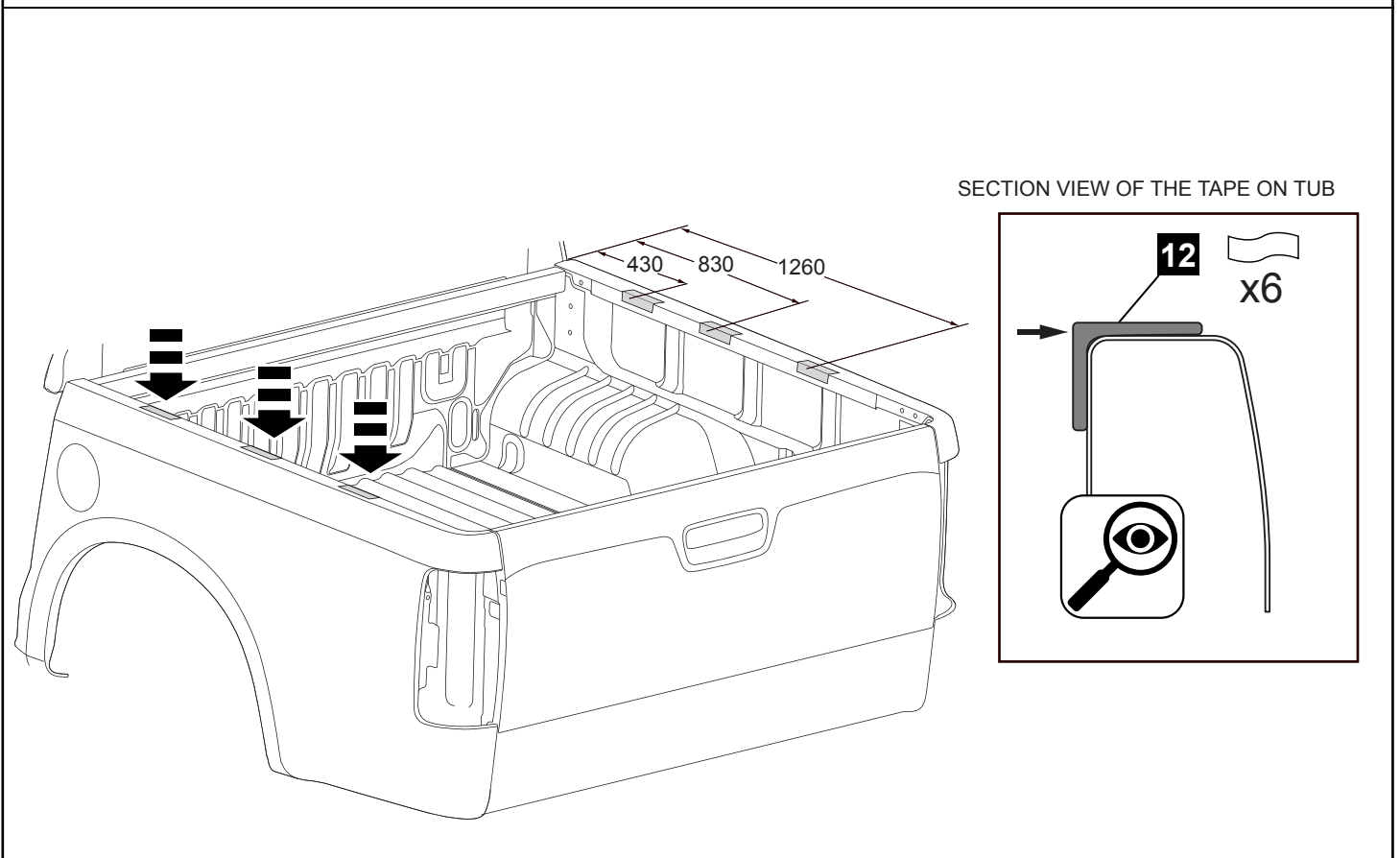

17 Clean top of the tub. Measurements taken from front of the tub to the centre of each tape, as per the diagram. Adhere 6 Abrasive Protection Strips (12) to the top of the tub at clamp locations. Position the tape so that it is aligned with the inside wall of the tub as shown.

11

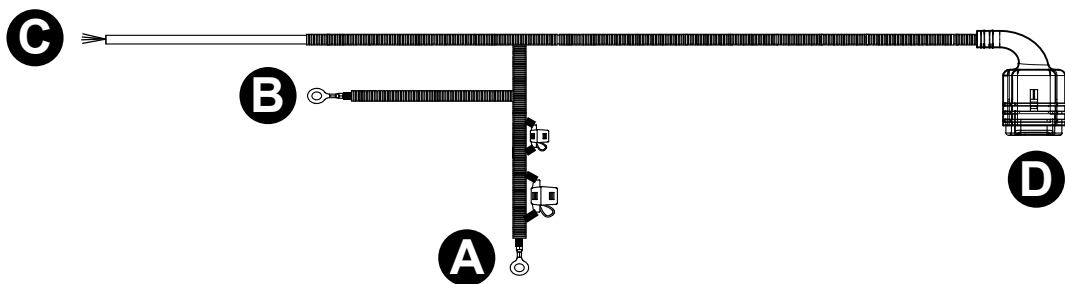

VEHICLE HARNESS LAYOUT - MAZDA BT50

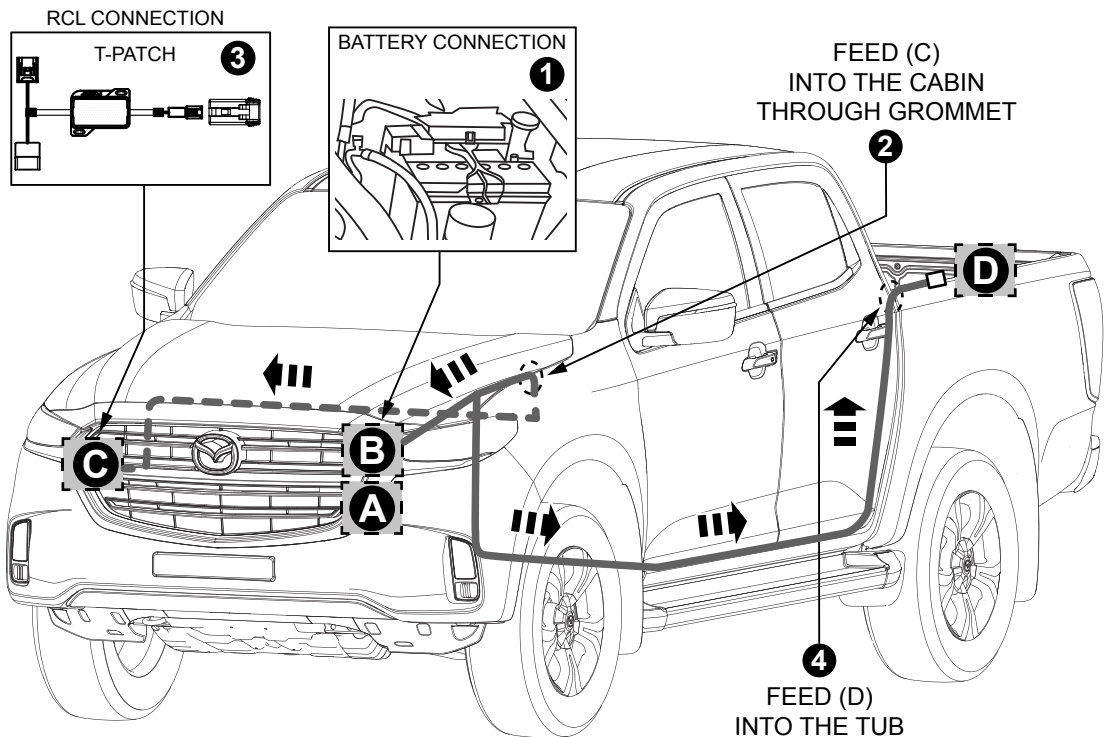

VEHICLE HARNESS LAYOUT - ISUZU D-MAX

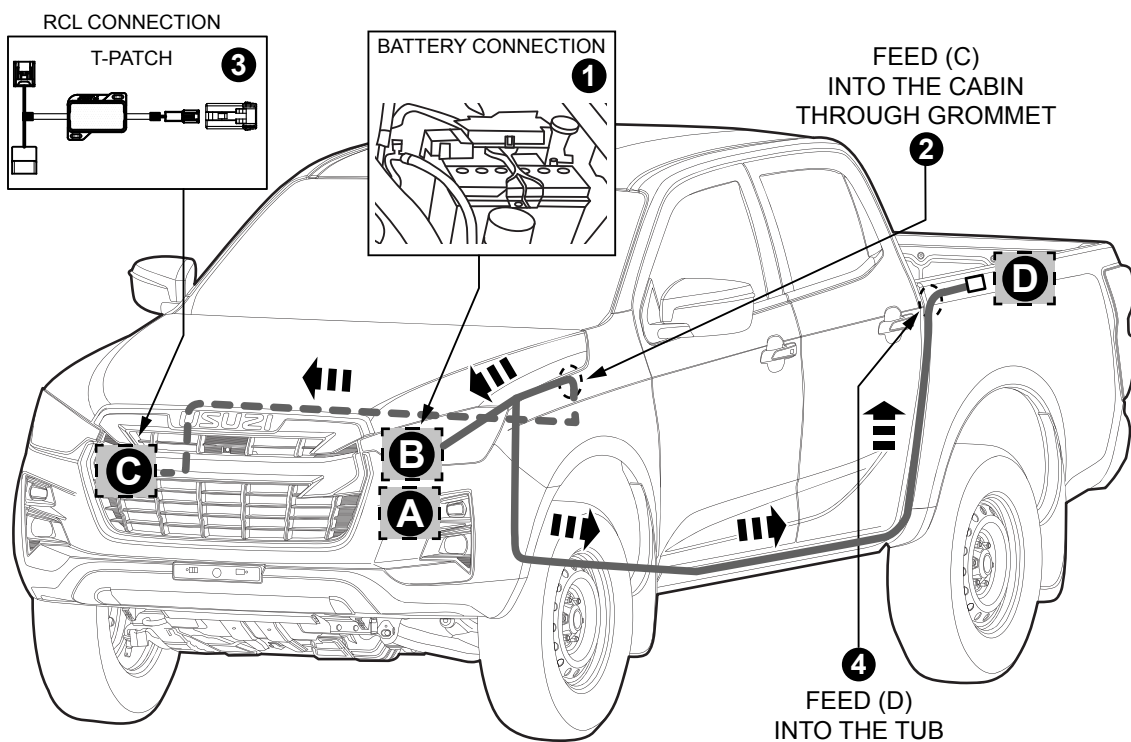



WHILE ROUTING THE VEHICLE HARNESS AVOID ANY VEHICLE COMPONENTS THAT HEAT UP, LIKE EXHAUST AND ENGINE COMPONENTS. DO NOT ATTACH HARNESS TO FUEL LINES AND AVOID PINCH POINTS.

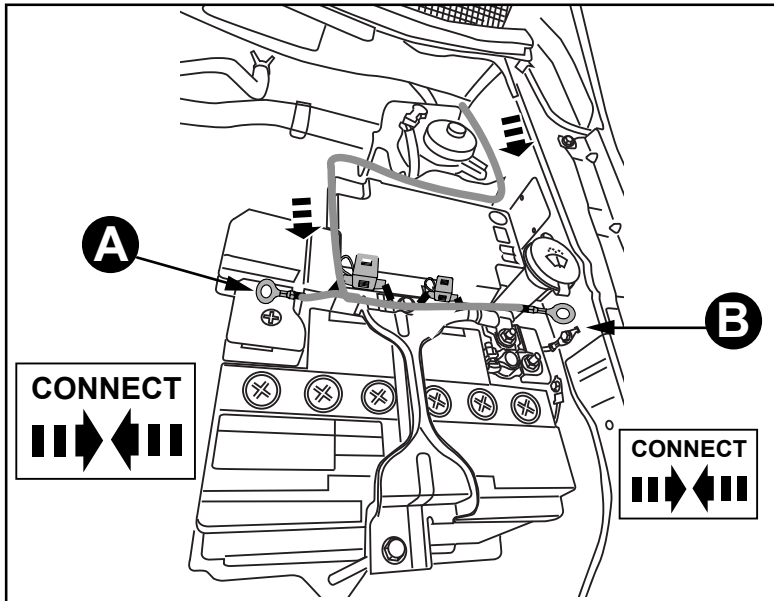

STEP 1

Connect the vehicle harness (branch A) to the positive battery terminal and the negative (B) to the chassis existing earth point on the inner fender as shown.



IMPORTANT: Do not fit the fuses at this stage.

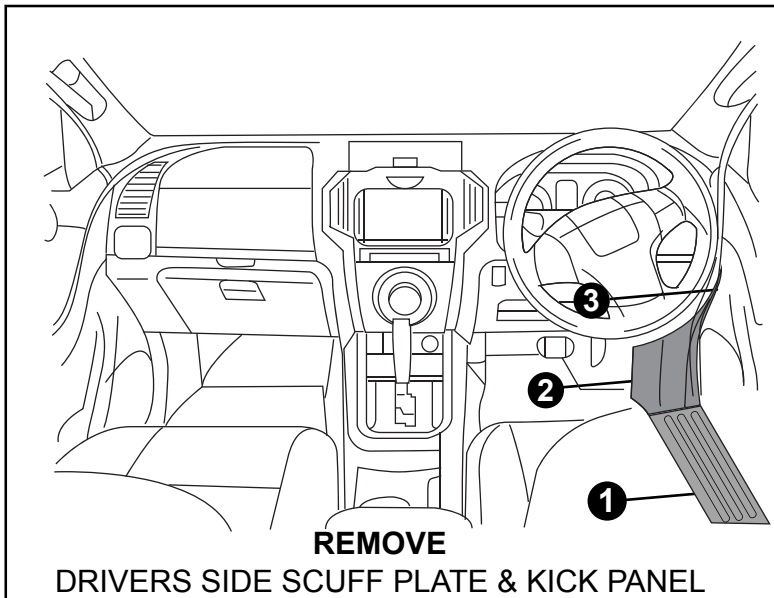

STEP 2

Remove driver kick panels & scuff plates by removing the hex nut and lifting it with flat screwdriver or trim removal tool.

Note: Remove the hex nut holding the kick panel first.

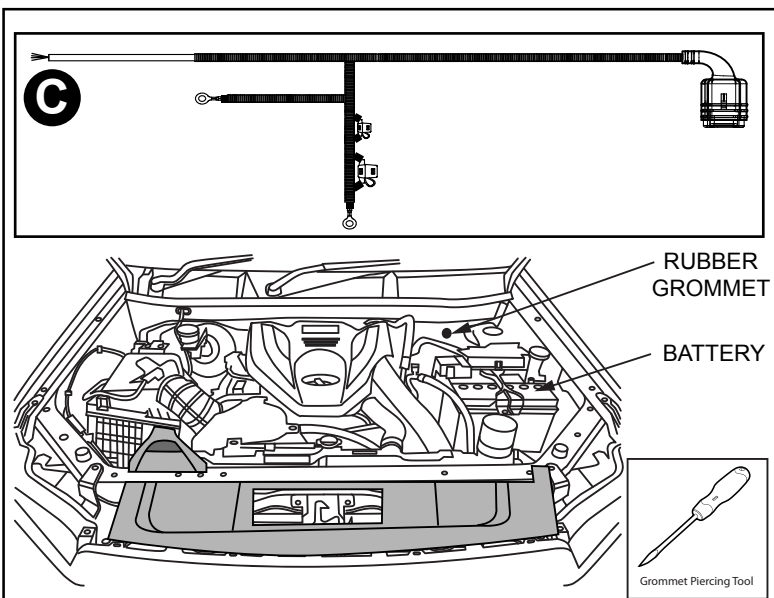

STEP 3

Using a Grommet Piercing Tool, punch a small hole in the grommet inside the engine bay on the fire wall near the petrol pump. Feed the Vehicle Harness (branch C) into the cabin on the passenger side through the rubber grommet.

Note: Use a pull wire if required.

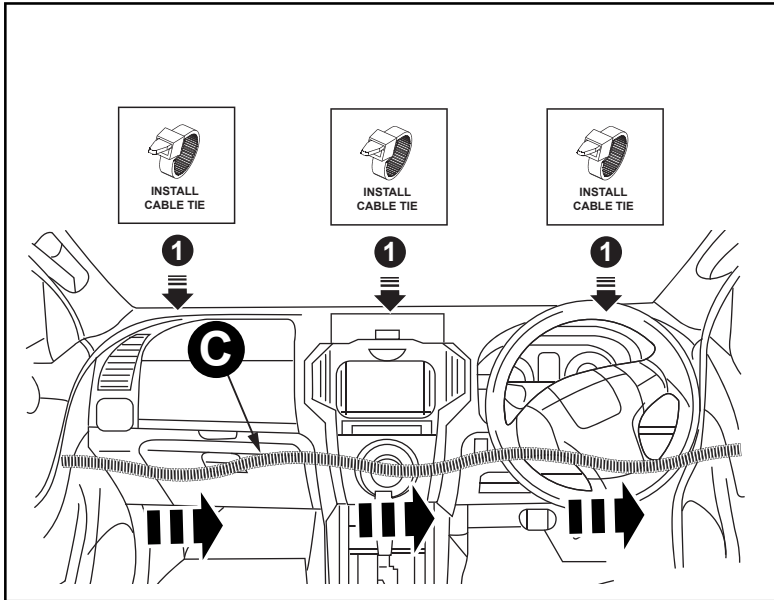

STEP 4

Run the Vehicle Harness (branch C) across from the passenger side to the driver side behind the dash board and secure with cable ties.

Note: Avoid sharp edges, moving parts like steering column and pedals.

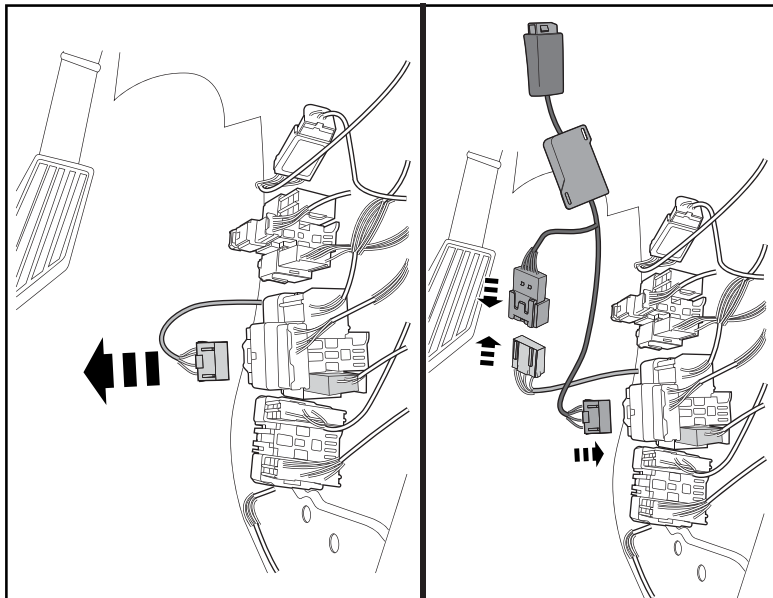

STEP 5

Disconnect the 14 pin connector as shown in the driver side foot well.

Bridge the disconnected connectors using T-patch as shown.

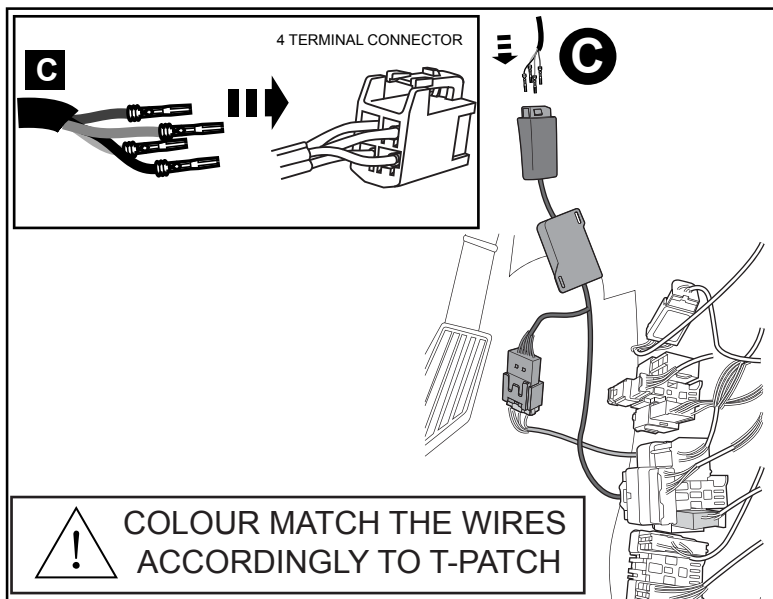

STEP 6

Pull the Vehicle Harness (C) close to the T-patch on the driver side. Unwrap the tape from terminals.

Connect the 4 wires to the connector (supplied) and plug into the T-patch.

Note: Make sure the wires are colour matched to the wires in the T-patch connector.

Refit the driver kick panel and scuff plate.

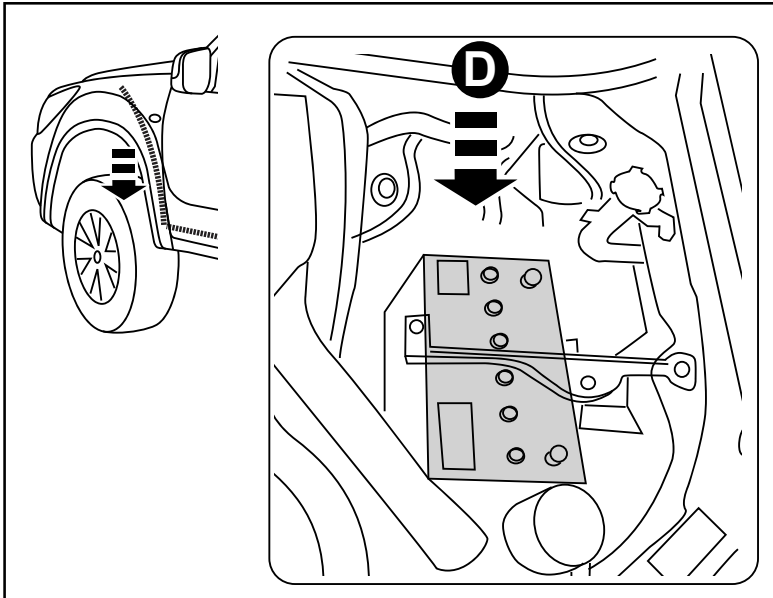

STEP 7

Feed the harness (branch D) down to the ground following the firewall and securing harness to the existing wiring.

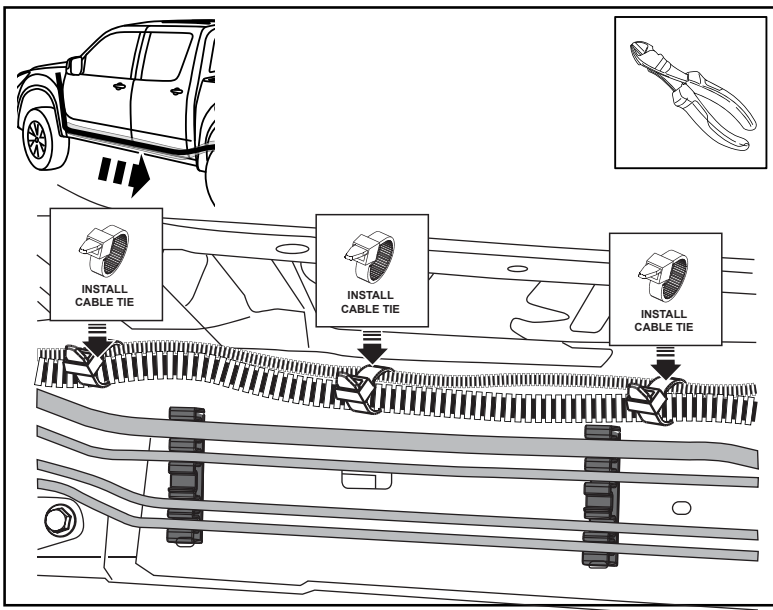

STEP 8

Run the Vehicle harness (branch D) under the vehicle towards the rear. Secure the harness to the existing harness along the chassis rail.

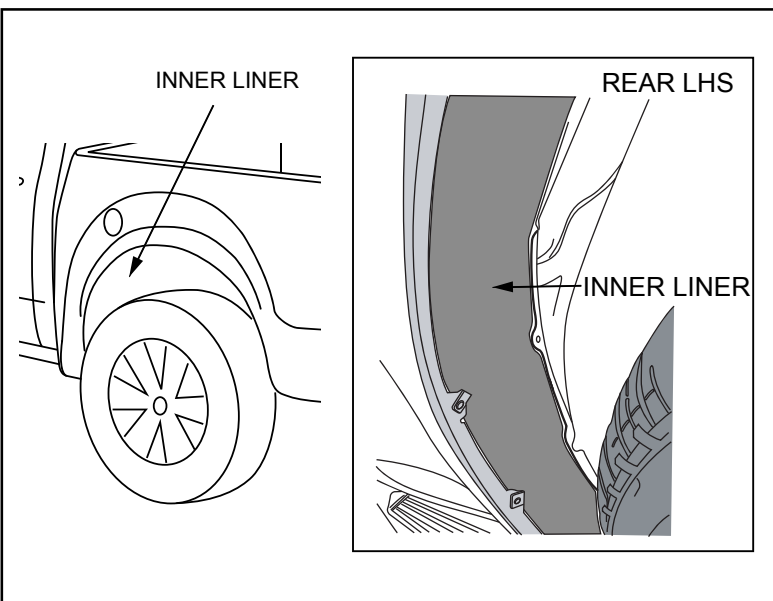

STEP 9

Remove the front part of the rear LHS wheel arch liner.

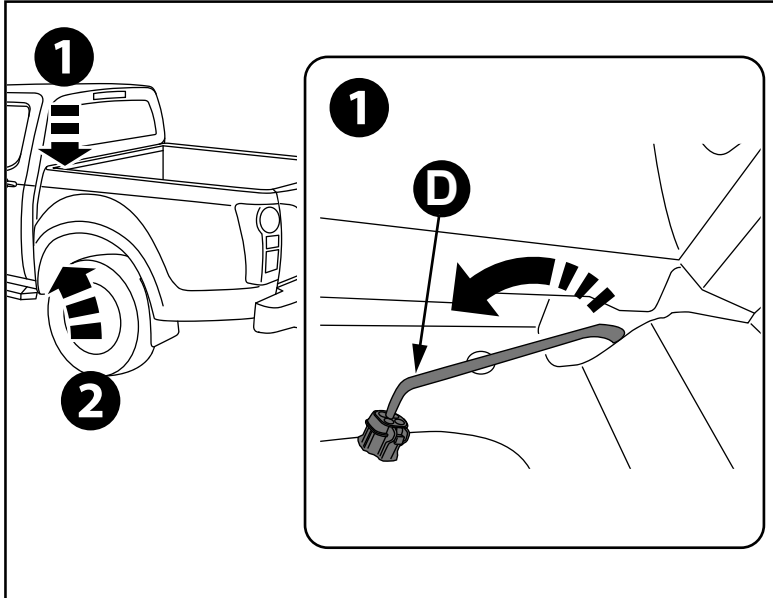

STEP 10

Feed a draw wire from inside the tub (cavity at the front LHS tub rail) down to the vehicle harness. Connect the draw wire to the vehicle harness (D) and pull into the tub.

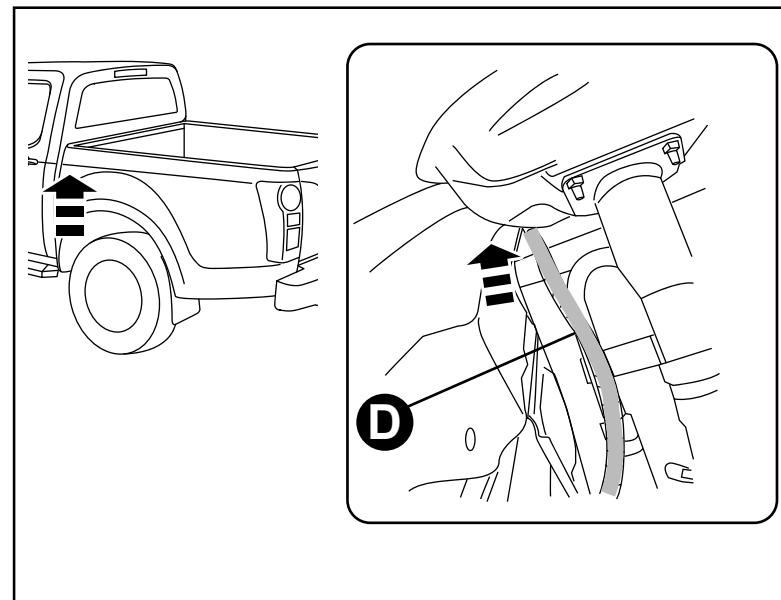

STEP 11

Secure the harness under the wheel arch and refit the removed wheel arch liner.



DURING ASSEMBLY PROCEDURE SUPPORT AT CENTRE OF CANISTER ONLY, PLACE ON TOP AND BASE CARTON (OR SIMILAR), COVER WITH FOAM BLANKET. TO AVOID SCRATCHING POWDER COATED SURFACES. DO NOT LOAD ELECTRICAL CONNECTORS OR MOTOR COVER.

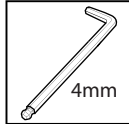
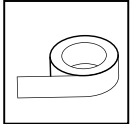

RHS FIT FIRST

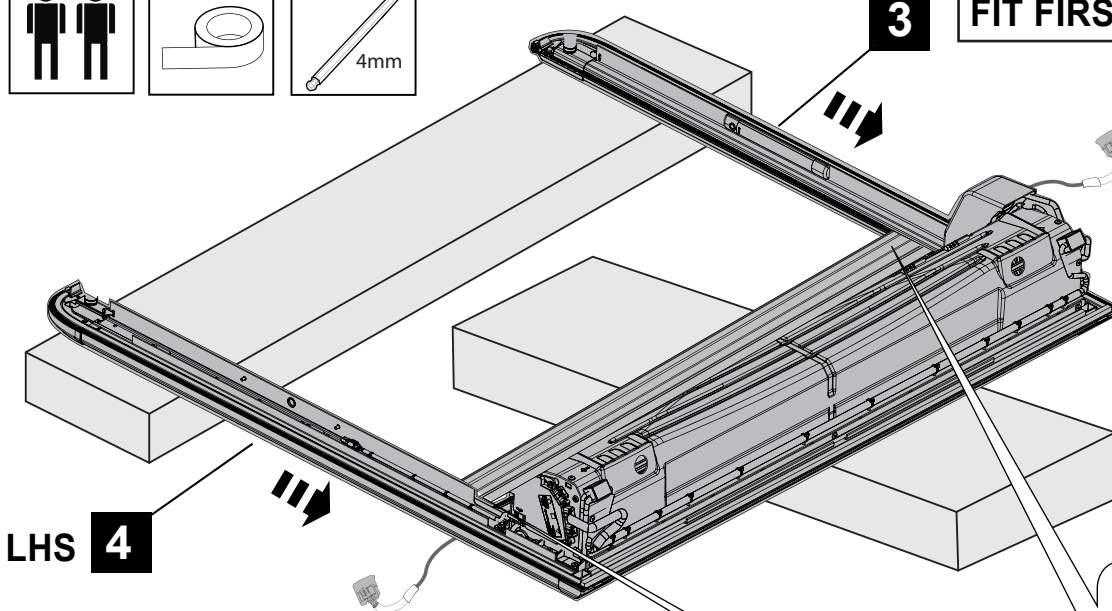

1



ATTENTION: SEAL MUST FACE IN THE DIRECTION AS SHOWN. WARRANTY VOID IF ASSEMBLED INCORRECTLY.

HOLD SEAL FLAT
USE CLOTH TAPE

RHS SHOWN

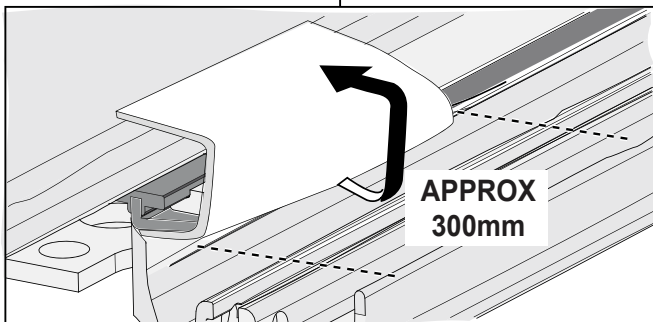
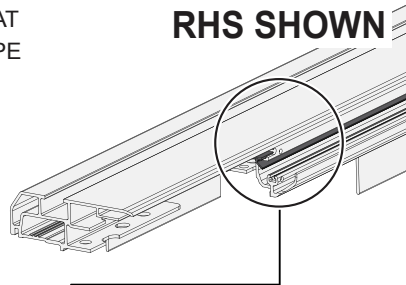
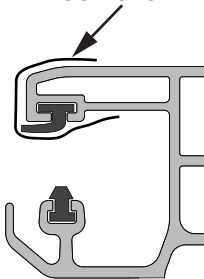

1 Place the canister (1) on two protected boxes as shown, ensure hand rail and slat ends are aligned. Tape up the seal on the Side Rail (5) as shown.

IMPORTANT: Carefully align and slide the rail over the handrail and canister endplate taking particular care to ensure that the siderails are slid straight and no undue force is applied to the rail. Details in following steps.

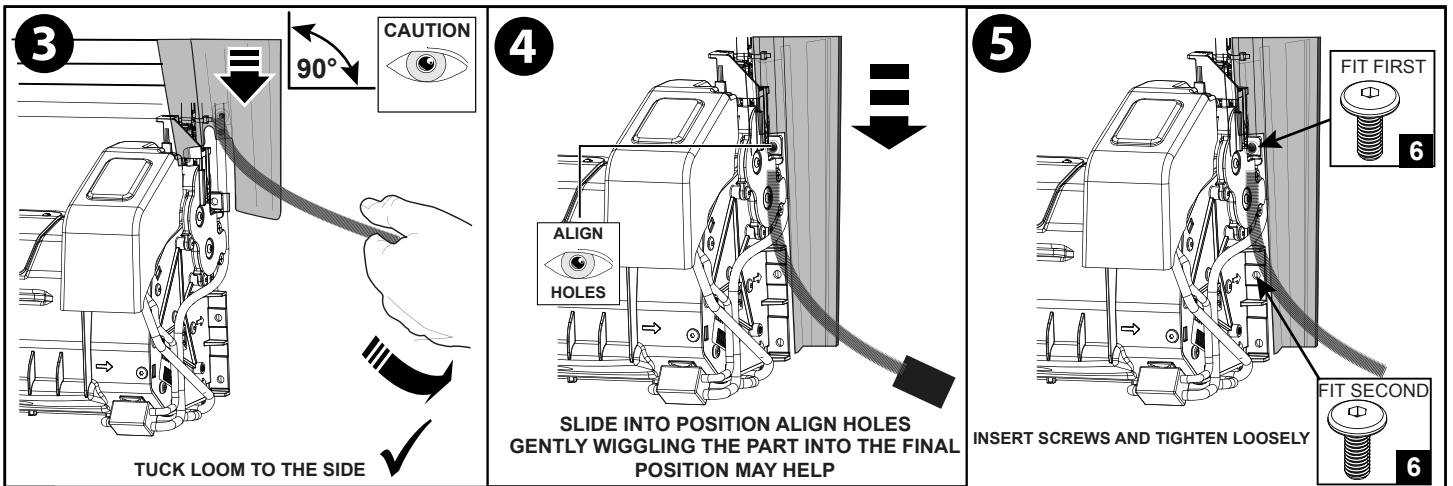

2 Pull hand rail to expose 3 slats. Slide the RHS Rail over slat ends and onto endcap location pins. Align the holes and secure loosely with two screws (6). Do not tighten. Repeat for LHS Rail (4)

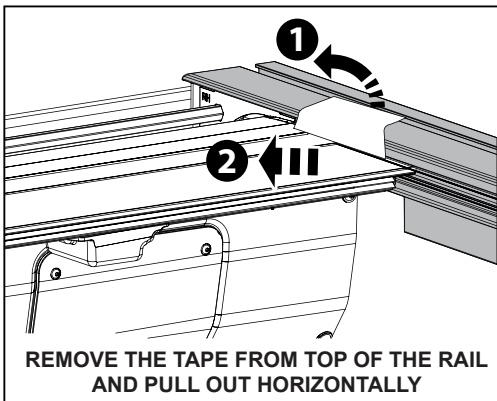
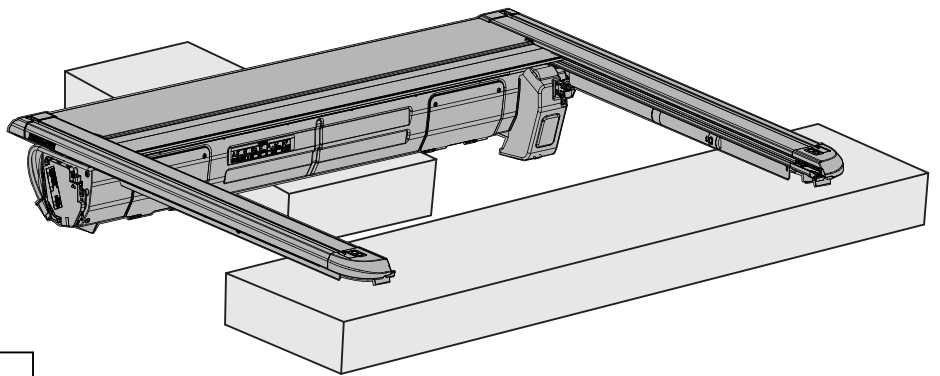
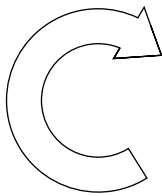

ATTENTION: SEAL MUST FACE IN THE DIRECTION AS SHOWN. WARRANTY VOID IF ASSEMBLED INCORRECTLY.

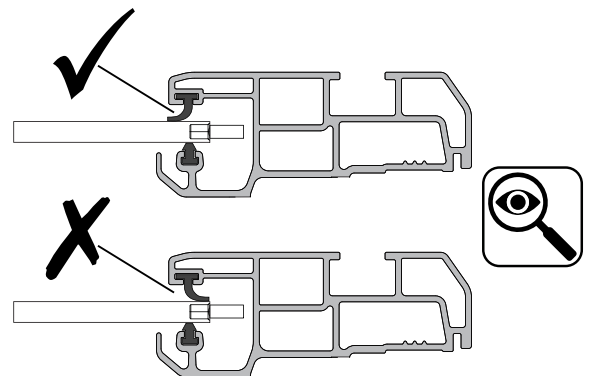
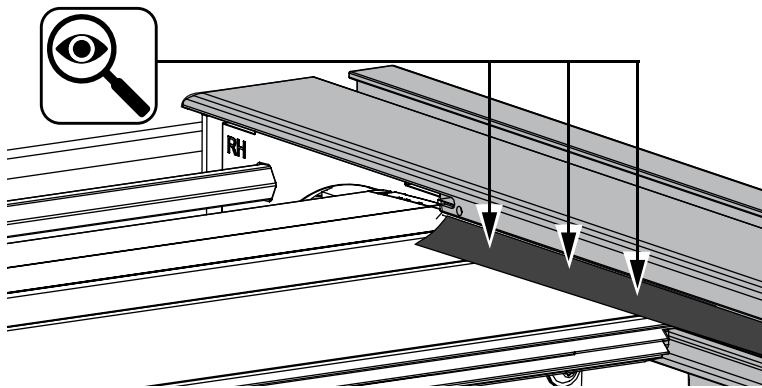

CHECK SEAL IS IN POSITION AND NOT DAMAGED

3 Carefully lay the assembly over onto a protected surface. Remove the tape holding the rubber seal and check the seal position as shown. Repeat for LHS Rail (4)

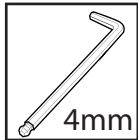

SIDE VIEW

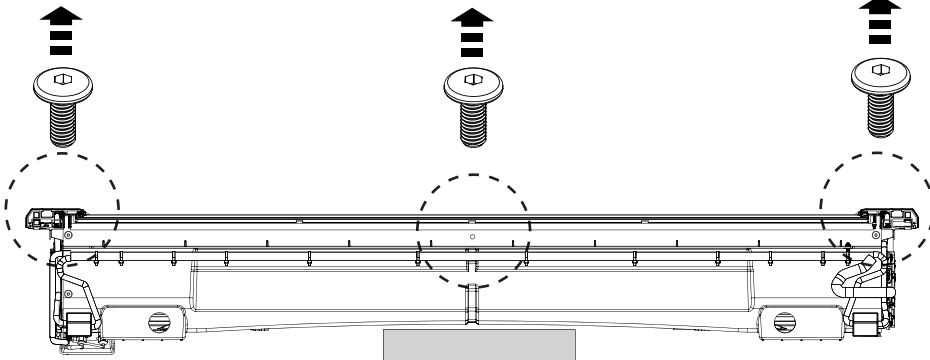
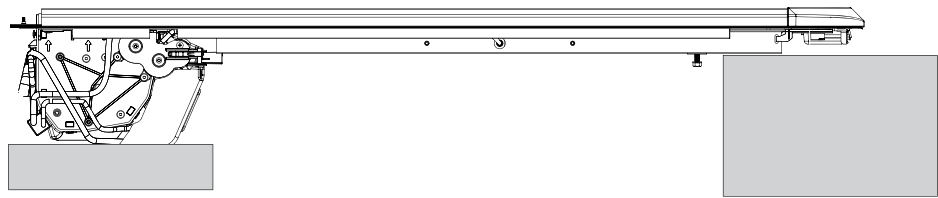

REAR VIEW

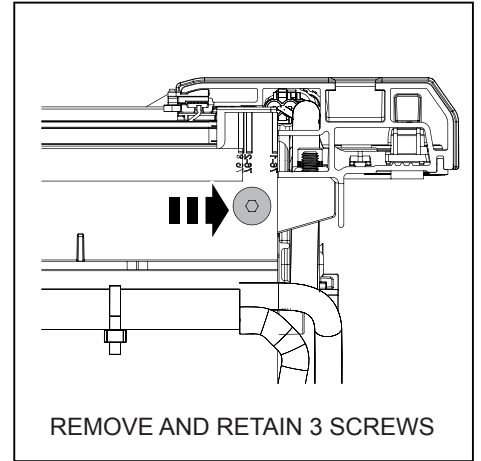

4 Remove the 3 pre-fitted screws from the rear of the cover which will be used to secure the Front Plate (1) to the assembly. Ensure the product is not scratched or damaged when laying flat.
IMPORTANT: Do not apply load to the electrical connectors and do not sit product on motor cover.

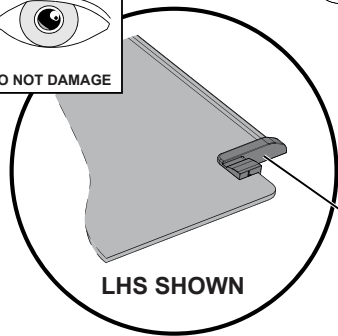

REMOVE TAPE SECURING THE RUBBER CORNER SEAL

ATTENTION: Remove foam tape end from the side rail before fitting into front cover

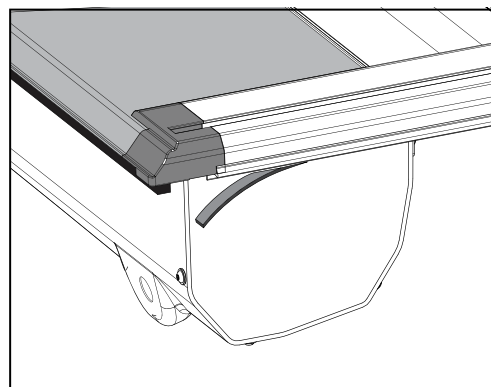
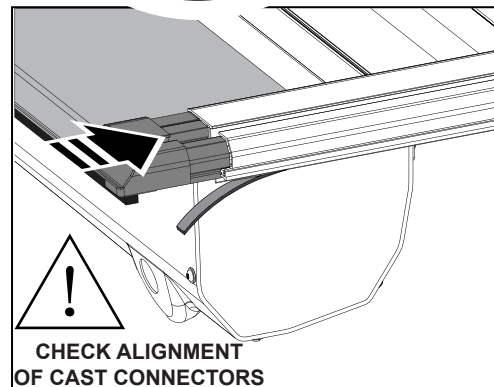

5 Slide the Front Plate (2) over the canister and into the side rail channels ensuring that the foam side rail tape is pulled out of side rail and the small rubber corner seal on the RHS and LHS of the front plate are not damaged.
IMPORTANT: Spray the front cover edge with soapy water to allow it to slide easily into the sides, twisting side rails outwards will also help.

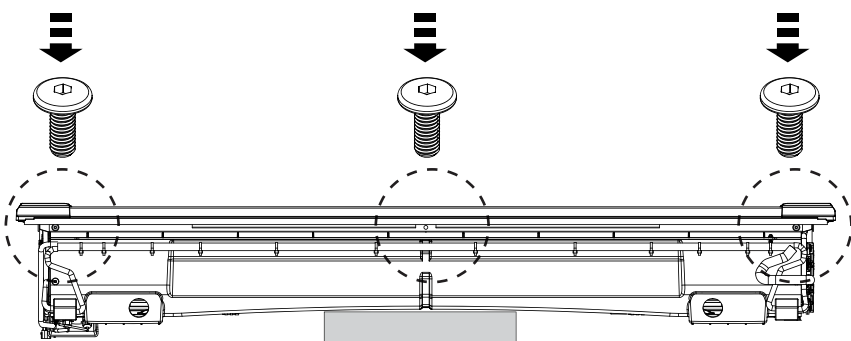
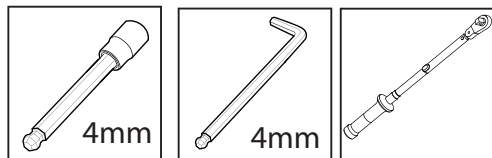

REAR VIEW

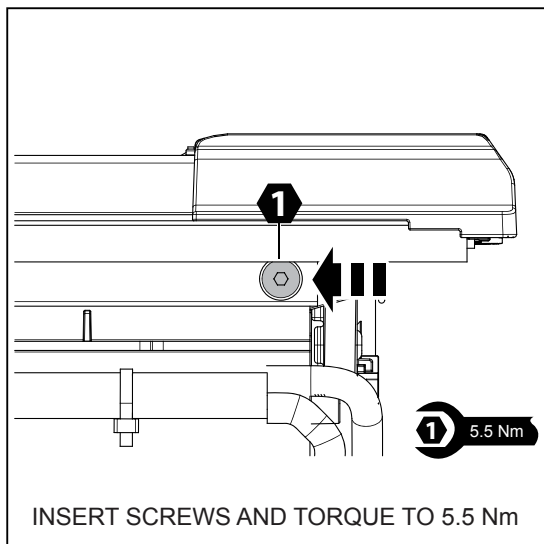

INSERT SCREWS AND TORQUE TO 5.5 Nm

6 Using the 3 screws removed from Step 4, screw the Front Plate (2) to the Canister Assembly (1) and torque to 5.5 Nm.

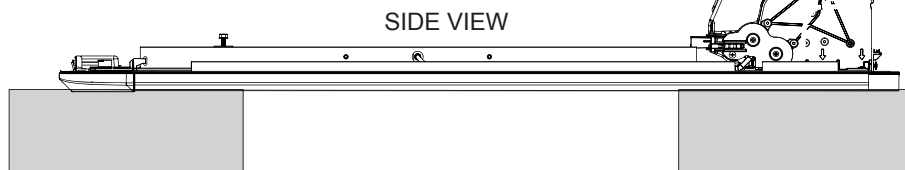
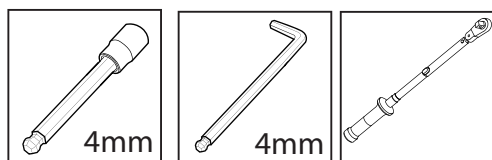

SIDE VIEW

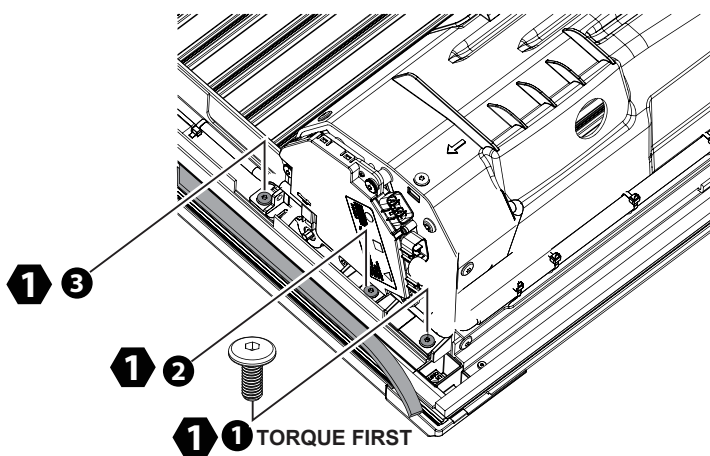

LHS SHOWN - RHS IS A MIRROR IMAGE

7 Carefully flip the assembly over onto a flat protected surface which will not damage the cover or scratch the paint work. Install the 2 screws (6) at the most rearward position first through the front cover to the side rails and torque to 5.5Nm followed by the remaining 4 screws (6) and torque to 5.5Nm.

LHS SHOWN - RHS IS A MIRROR IMAGE

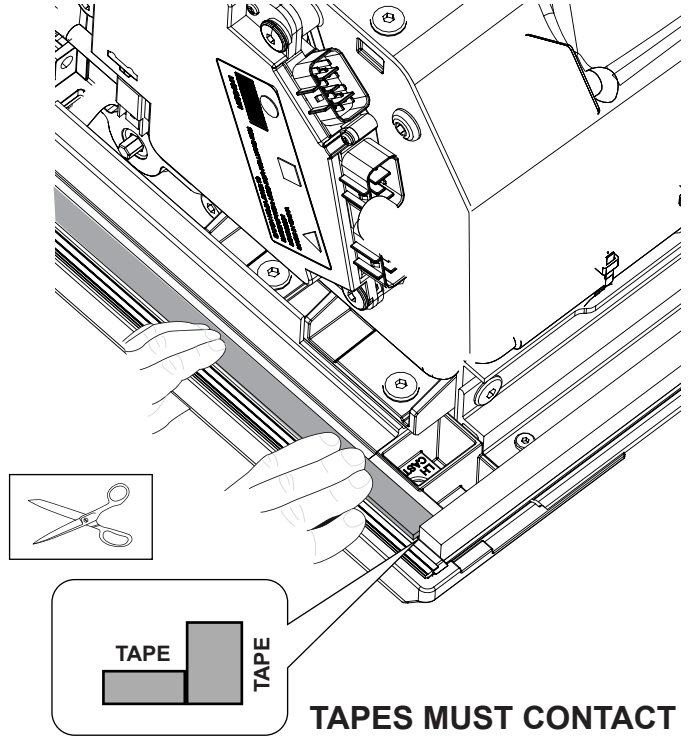
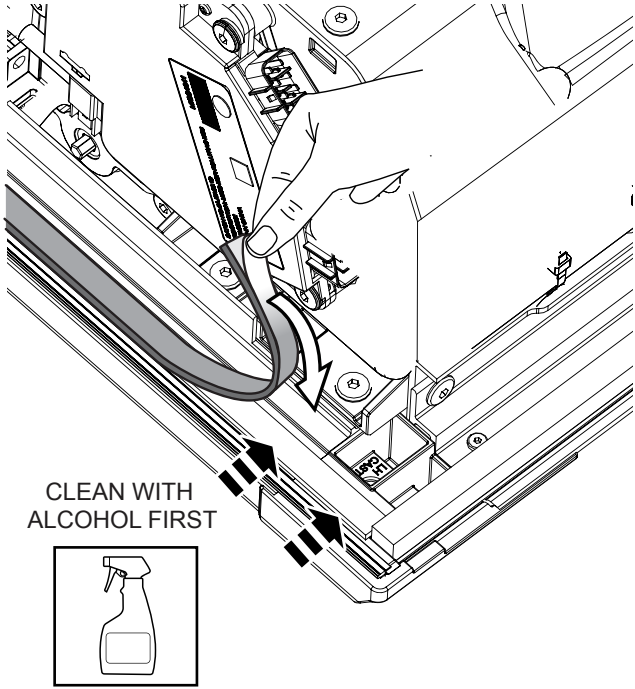

8 Clean powder coated surface first with alcohol spray. Trim foam tape length to ensure the end will butt against front cover seal - avoiding any gap. Peel the protective liner from the foam tape, adhere to the channel in the side rail, Press down firmly to secure. Repeat on RH side rail.

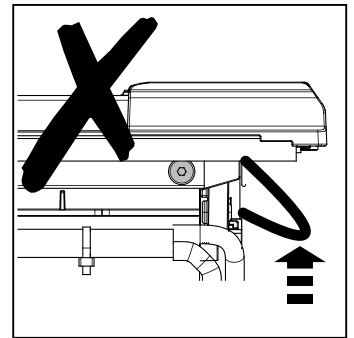
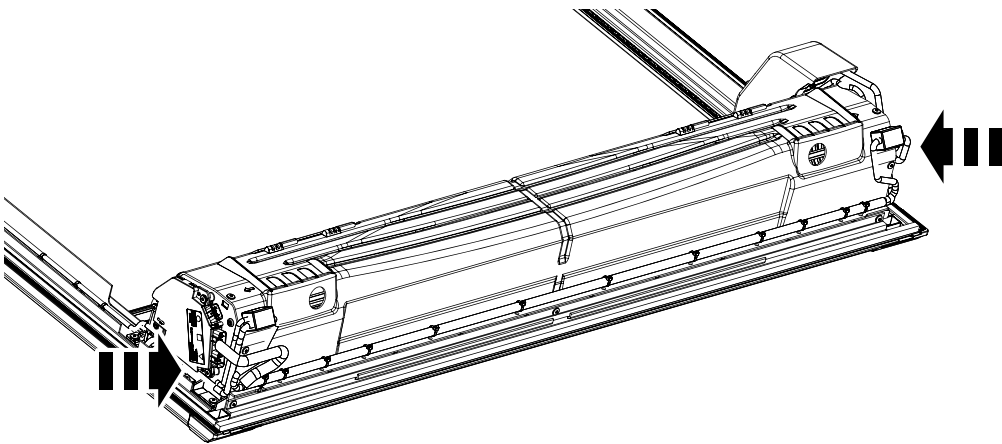

SECURE ALL CABLES TO PREVENT PINCHING

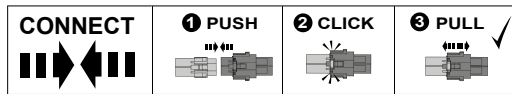
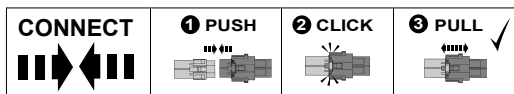

PULL THE CONNECTOR NOT THE CABLE

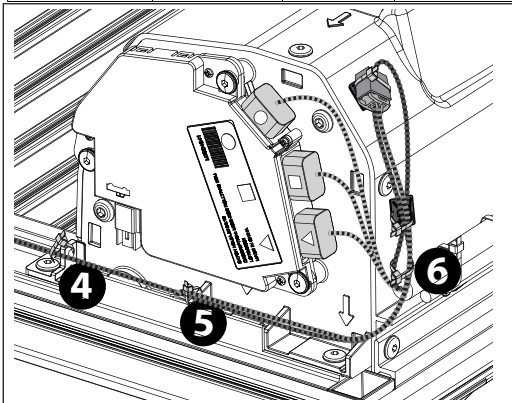
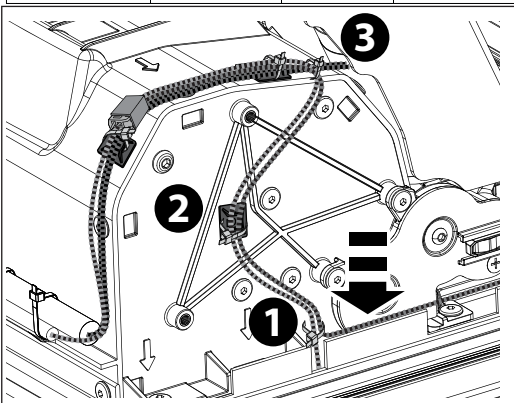

9 Connect side rail harness connectors to the connectors on the canister on the LHS and RHS. Secure the harness to the canister using cable ties at the six locations shown. Secure with zip ties and pads. Ensure all cables are retained to prevent pinching during installation.

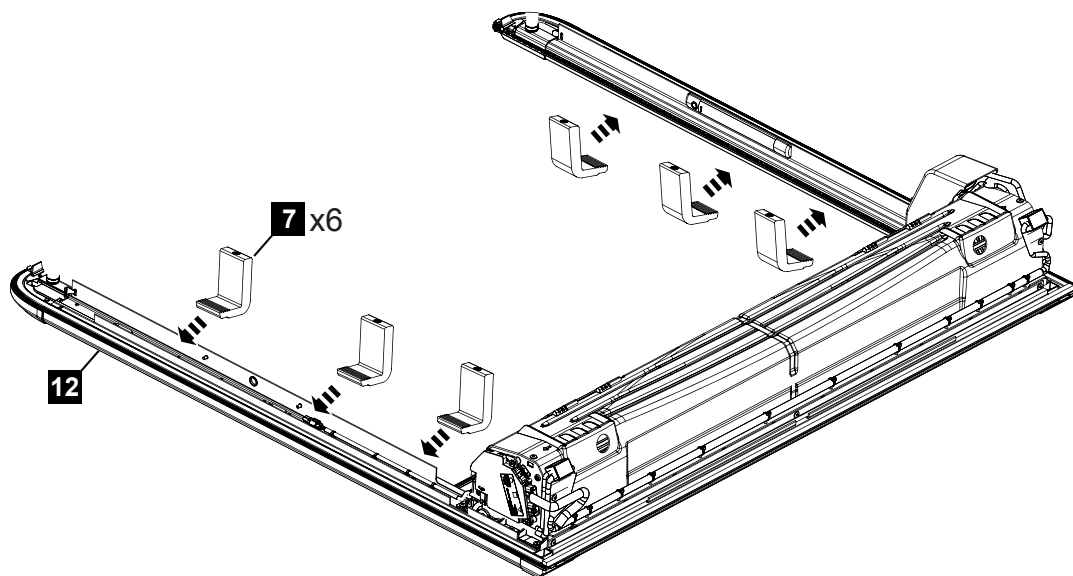
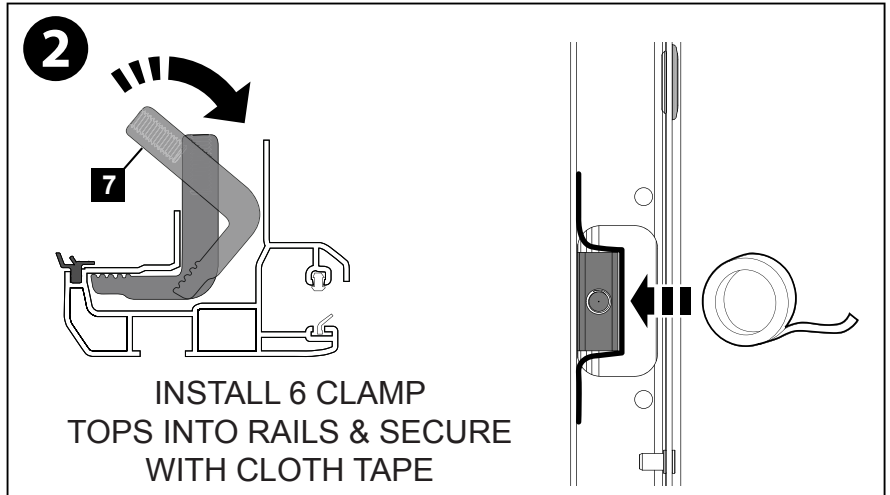
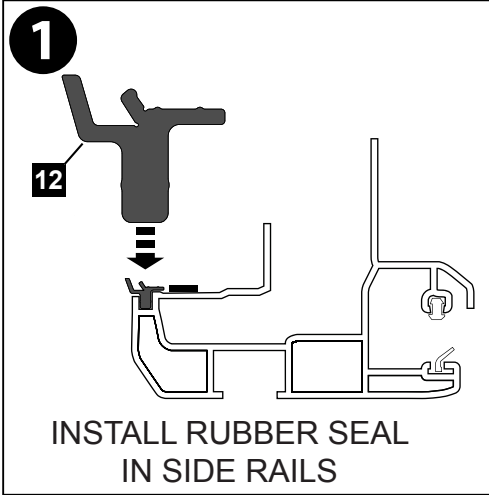

- 10** 1. Install the Rubber Perimeter Seal (12) into each side rail and ensure seal is firmly seated (note the seal orientation).
2. Install the six Clamp Tops (7) into the LHS and RHS side rails and secure with cloth tape to temporarily hold in position.

CONTINUE ON THE NEXT PAGE



HEAVY

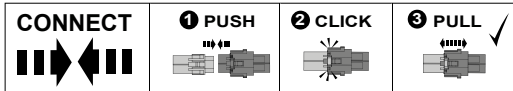
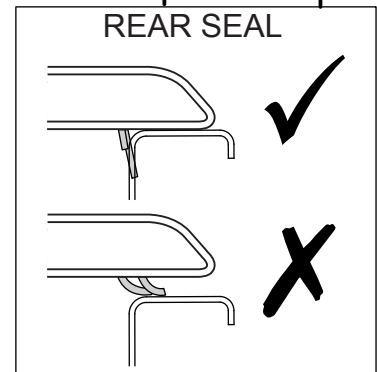
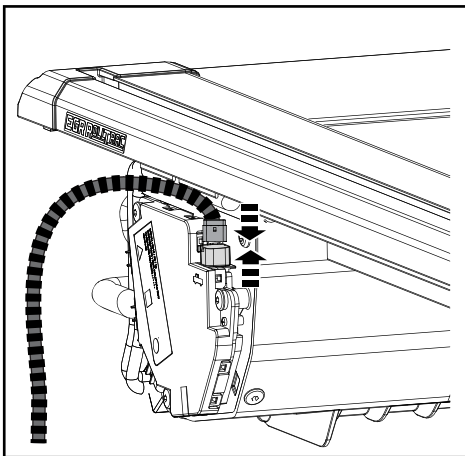
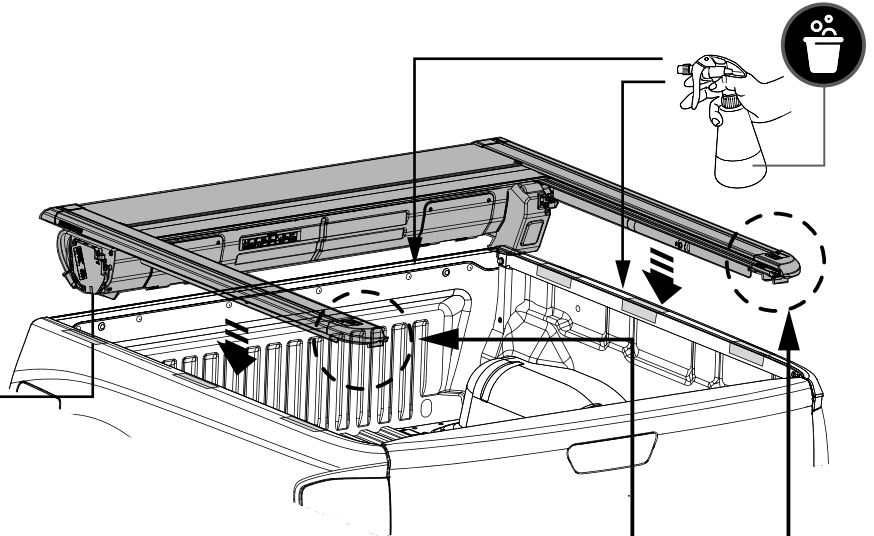

PULL THE CONNECTORS
NOT THE CABLE

1 Spray the top surface of the tub liberally with a soapy water solution to enable the Cover to slide easily. Using two people to lift the cover from both sides and carefully lower it onto the tub. Connect the vehicle harness to the ECU as shown. **NOTE:** You may have to lift the LHS of the cover and use packer to aid connection. Ensure rear seals are sitting vertically as illustrated.

CONTINUE ON THE NEXT PAGE

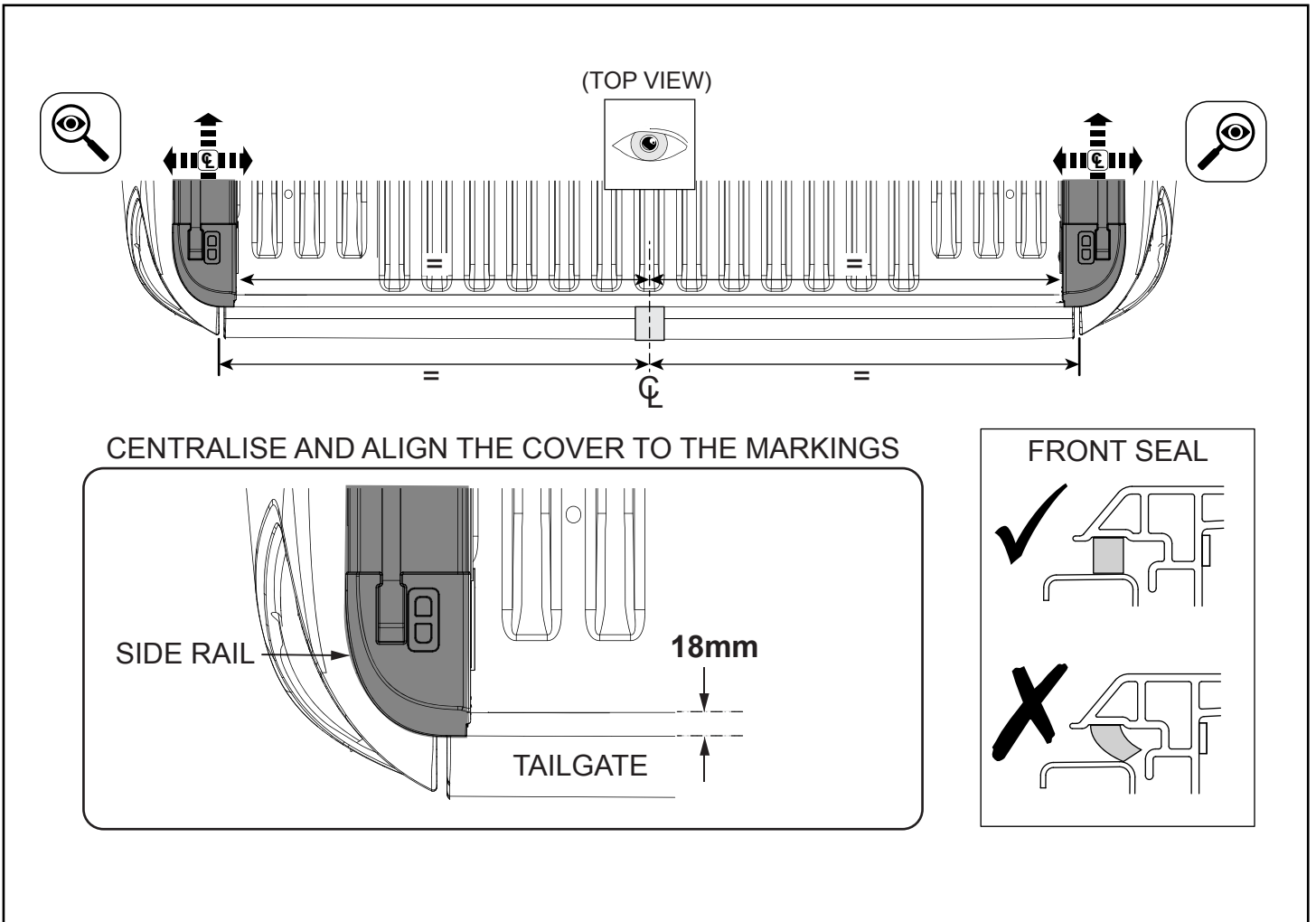

2 Adjust the cover as shown. Ensure seals are not deformed by lifting cover and dropping vertically on tub.

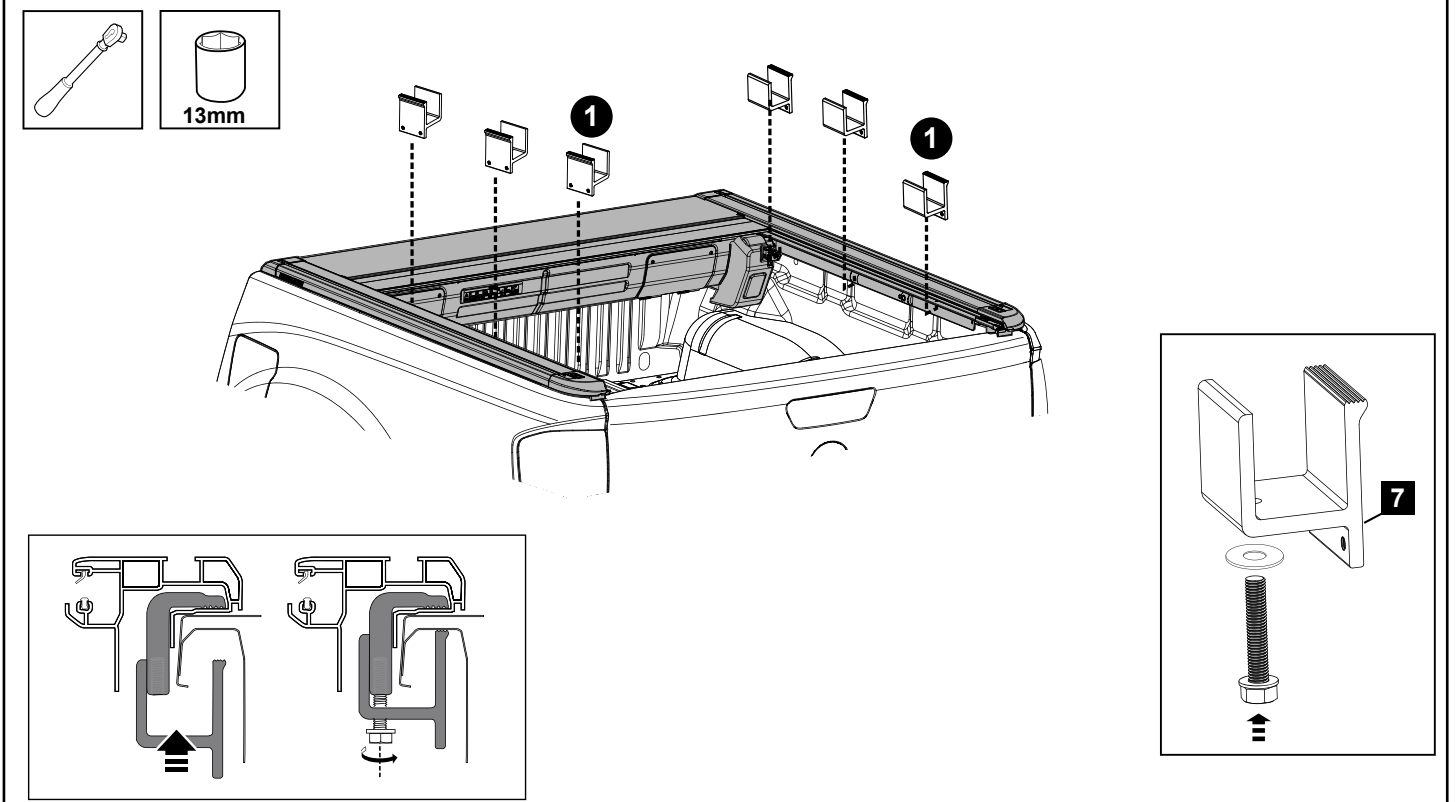

3 Loosely install the LHS and RHS clamp bases (7). DO NOT TIGHTEN. IMPORTANT: Ensure to install washers as supplied in the kit.

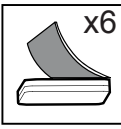
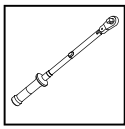

A = A B = B

PERFORM FITMENT CHECK

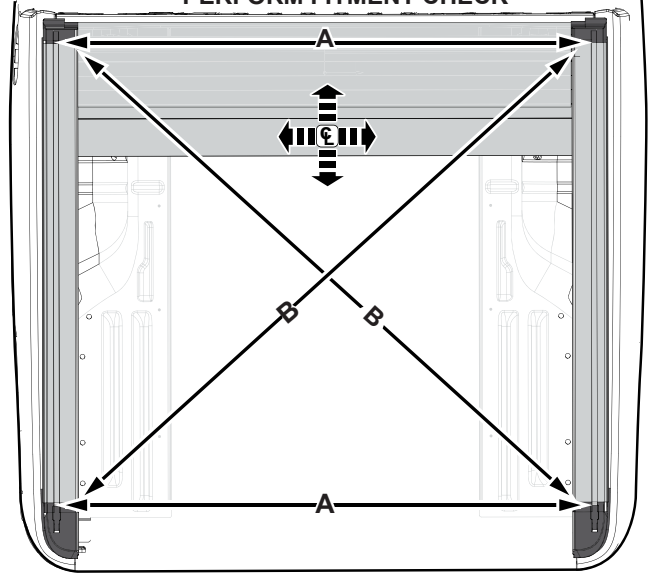
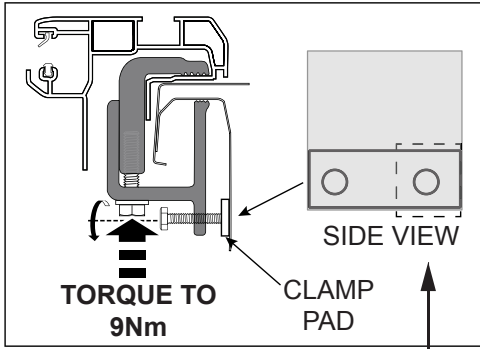

ATTENTION: The side M6 bolts should be tightened until it contacts with the rectangular clamp pad. The bolts should not be tightened any further.

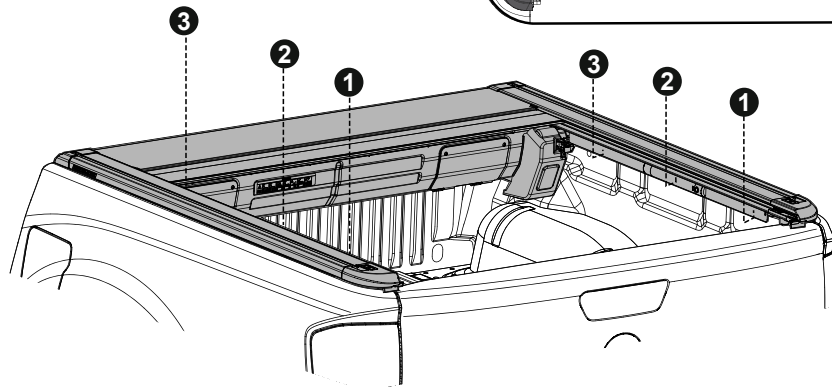

4 Torque (9Nm) the rear set of cover clamp bolts, ensuring cover does not move after tightening. Perform diagonal fitment check (bolts may need loosening for adjustment). At this stage the clamp bolts should be tightened from tailgate to the cab to 9Nm.

FIT FRONT DRAIN TUBES TO THE CANISTER

FIT REAR DRAIN TUBES TO SIDE RAILS

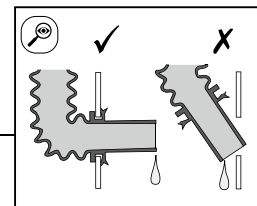
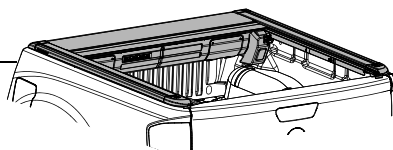
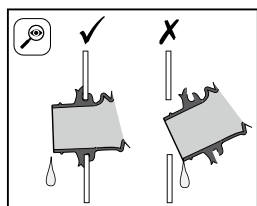
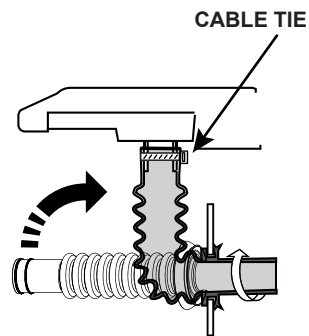
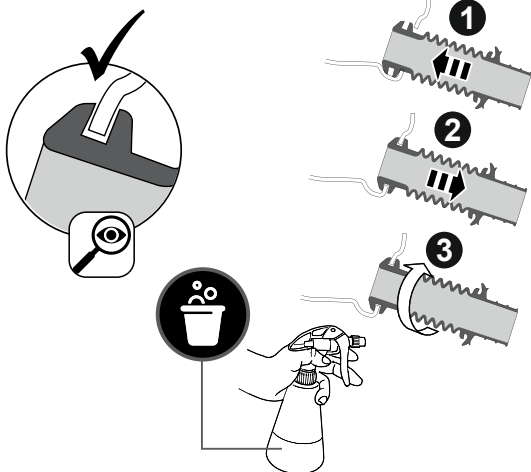

5 Connect the front drain tubes (8) to the canister cover. Connect rear (9) drain tubes to the vehicle tub, making sure that both tubes engage over the wall of the tub. Leakage will occur if they are not properly installed.

SILICONE LUBRICATION TO THE SPIRALS (MODELS MAY VARY, IMAGES FOR REFERENCE ONLY)

1 Open tailgate and EGR RollTrac

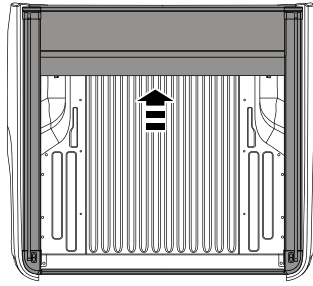
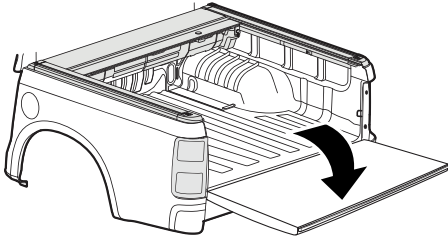

TOOLS REQUIRED:

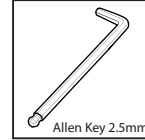

2 Using a 2.5mm Allen Key remove the 4 screws and open the inspection covers.

WARNING: Keep clear of moving parts and avoid unnecessary operation of the EGR RollTrac while inspection covers are open.

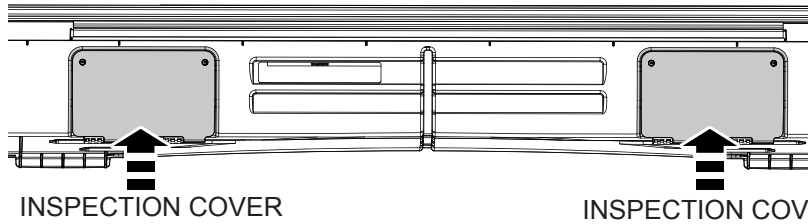

3 Close the EGR RollTrac to access canister internals

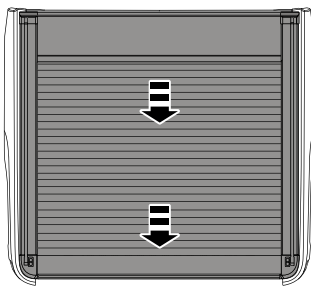

4 To avoid water leaks, look into the inspection points and check that the flanges of both front drain tubes are correctly engaged to the canister cover (without any kinking etc.), readjust if required.

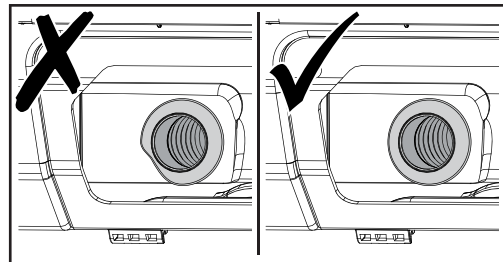

5 Using plastic compatible 100% Silicone Spray (ONLY) spray onto the spirals on both ends of the canister through the inspection points.

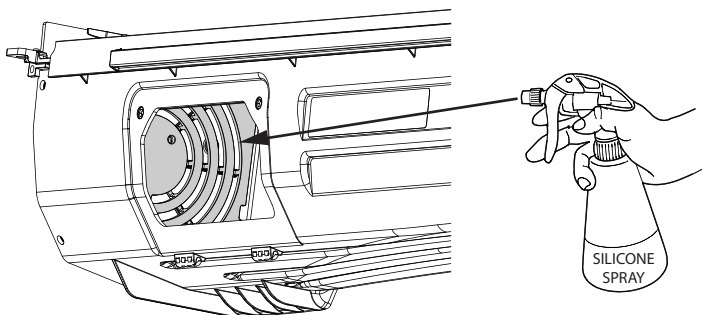

6 Open the EGR RollTrac

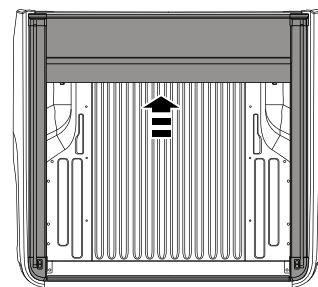

7 Close the inspection covers and secure with retained screws. Open and close the EGR RollTrac to distribute lubricant and check operation.

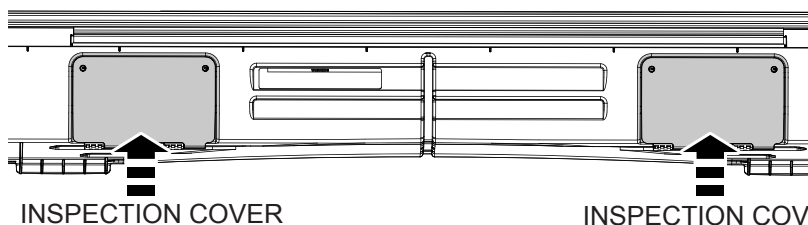

1. Insert fuse to EGR RollTrac harness.
2. Make sure the tailgate is open.
3. Engage motor, pull out lever (clutch).
4. Make sure the vehicle is unlocked and driver door open.
5. Press both buttons and hold for 10 sec. until light illuminates.



WARNING: Keep obstructions clear of cover during calibration mode.

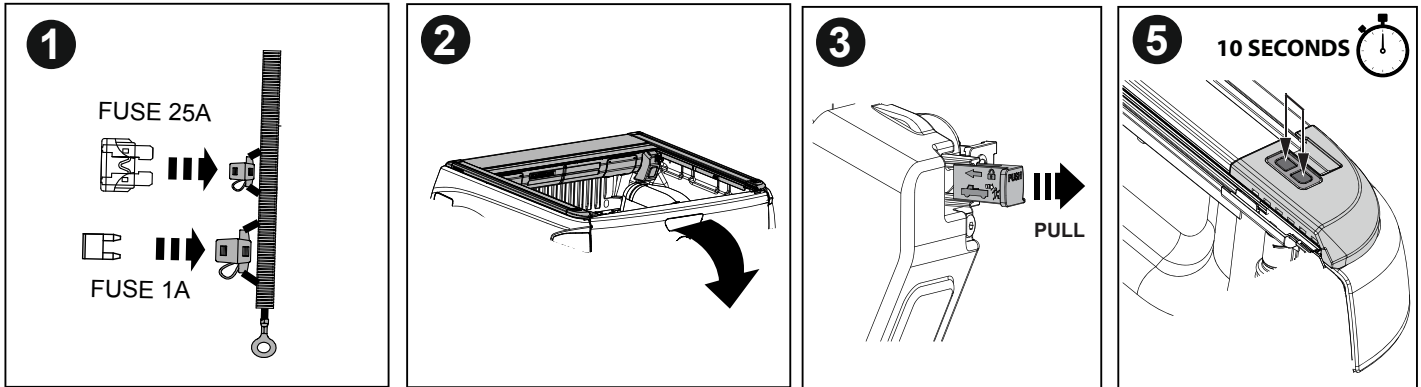

- Cover will open and close twice automatically.
- The EGR RollTrac internal LED light will pulse slowly during calibration and stop pulsing when calibration is complete.

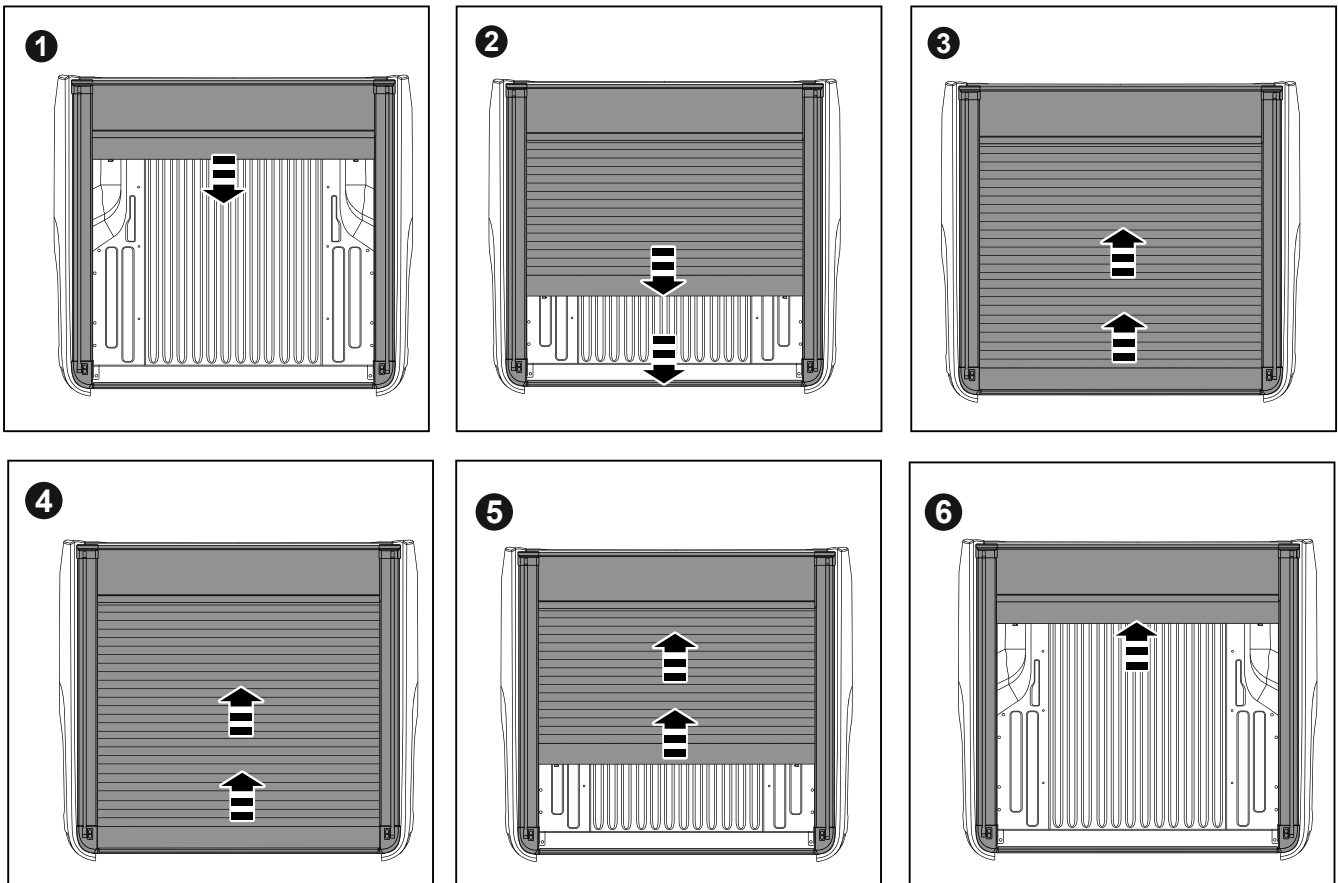
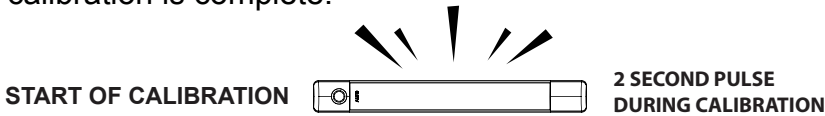

OPENING AND CLOSING PROCEDURE

Electric Opening Procedure:

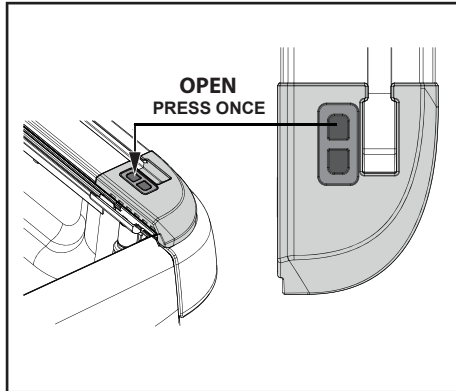
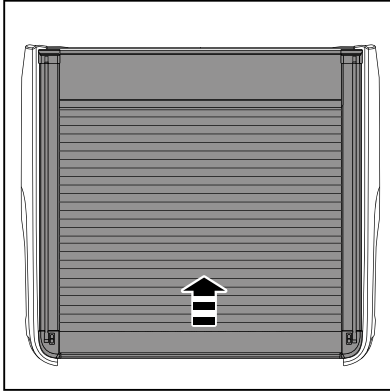

1. Press the front button on the EGR RollTrac side rail as shown.

Electric Closing Procedure:

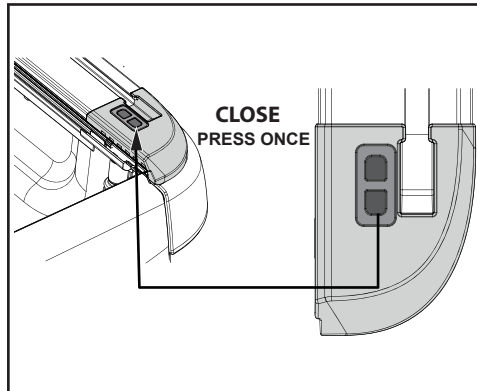
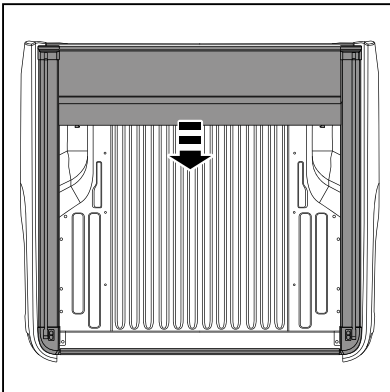

1. Press the rear button on the EGR RollTrac side rail as shown.

NOTE: EGR RollTrac should open and close smoothly. If cover does not lock or open correctly, please refer to the trouble shooting section in the Owners Manual. If the EGR RollTrac closing is slow, clean the siderails and ensure that no dirt or debris is inside the drive rail.

Manual Opening and Closing Procedure:

Locate the Clutch Disengagement Lever on the RH side of the cover and push the Clutch inward to disengage the motor. Pull the cover rearward or forward as required. Before driving vehicle ensure you re-engage the clutch.

IMPORTANT: If clutch was disengaged, calibration procedure needs to be re-run prior to electric operation.

