

# INSTALLATION INSTRUCTIONS

# **EGR** *ROLLTRAC*

## ELECTRIC

**Vehicle model:** RAM DT/1500 5.7Ft Bed RHD (New Body Style)  
(Excludes models with RAMBOX® or other options / accessories that would affect RollTrac fitment)  
**Year of Manufacture:** MY 2019 Onwards

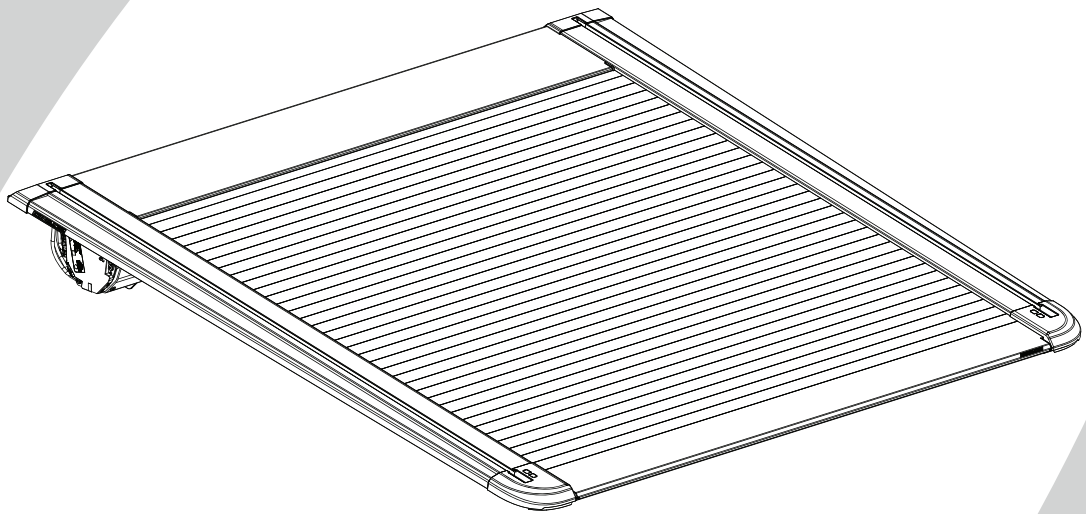

Installation time: 180 minutes

### Caution

- Do not attach EGR RollTrac in a location or by a method not specified.
- Do not use this product for any vehicle make or model, other than those specified in this document.
- Do not remove the plaque or label from this product.
- Do not modify the structure of the EGR RollTrac in any way.

### General Notes

- Read through the fitting instructions before installation of EGR RollTrac.
- Always install the accessory following the fitting instructions. Failure to do so may cause damage to the vehicle or the accessory.
- Ensure all recyclable discarded vehicle accessory components and packaging are recycled following local recycling regulations.
- It is always recommended that this accessory is fitted by a qualified Technician.
- Safely store and protect any removed vehicle components.
- Ensure all bare metal surfaces are protected using Automotive Bare Metal Primer and touch-up paint.
- Remove all metal swarf and dust from all vehicle surfaces if surface is used for accessory installation.



### Safety Notes

- Check that all work practices comply with safety standards.
- Please wear appropriate clothing and use safety equipment.



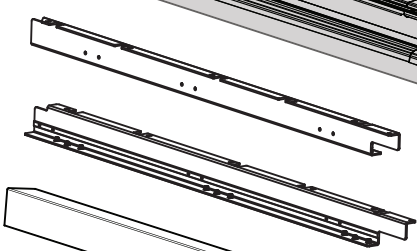
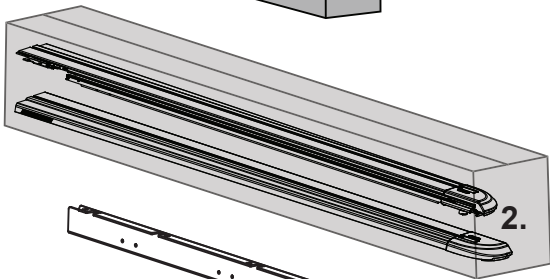
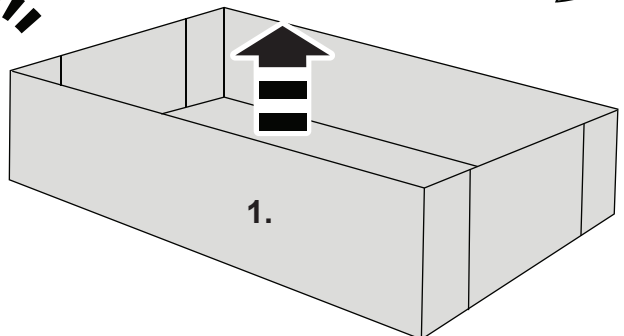
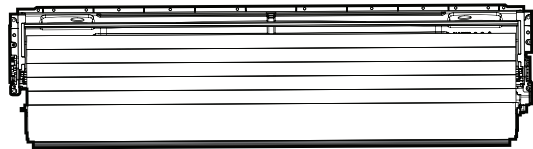
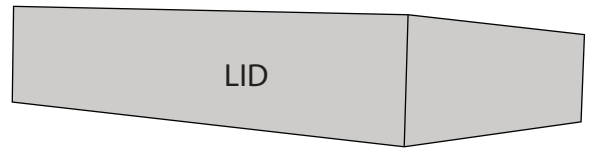
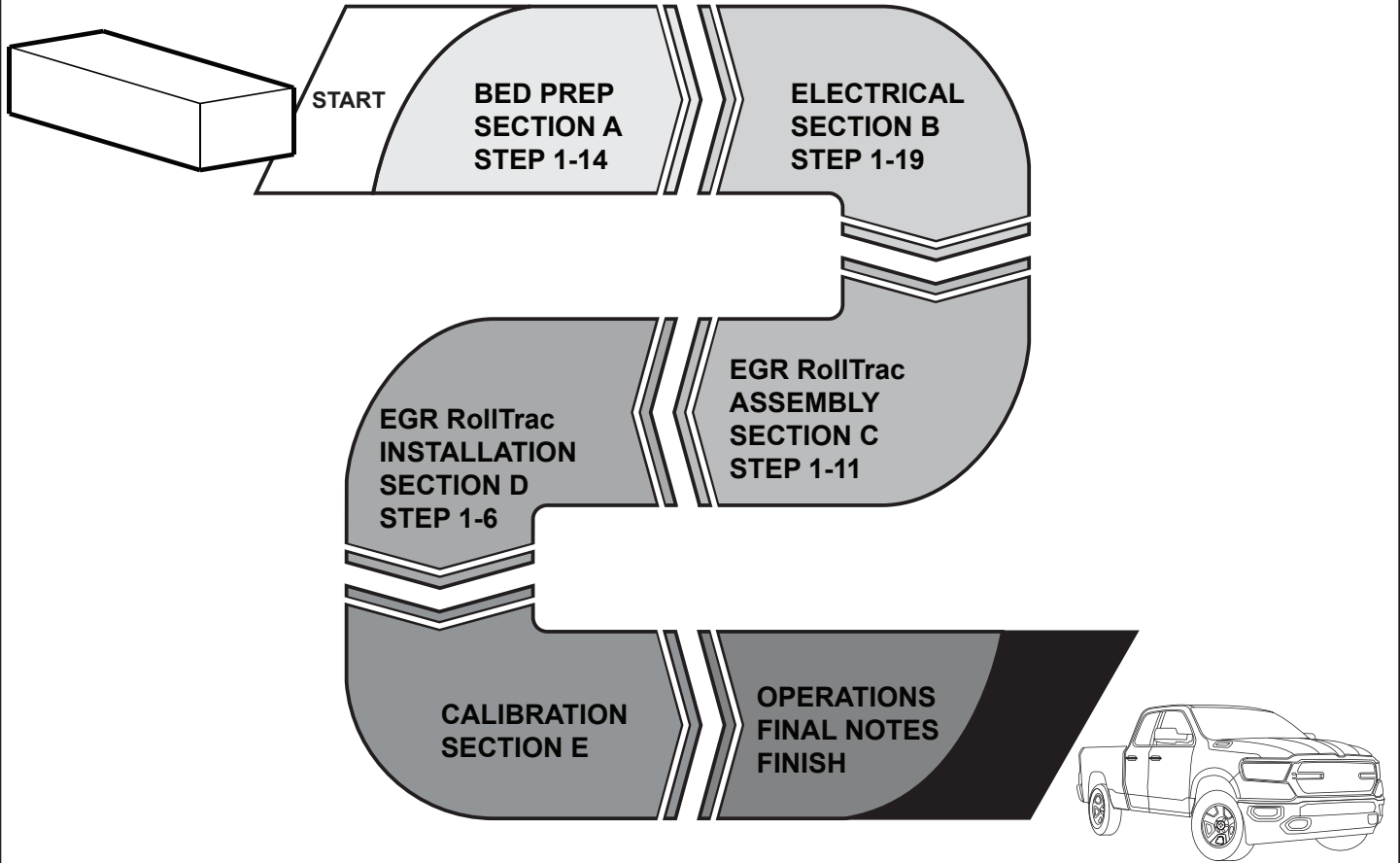

## KIT CONTENTS - COMPONENT NUMBER AND QUANTITY

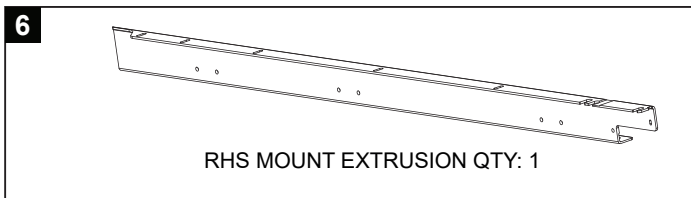
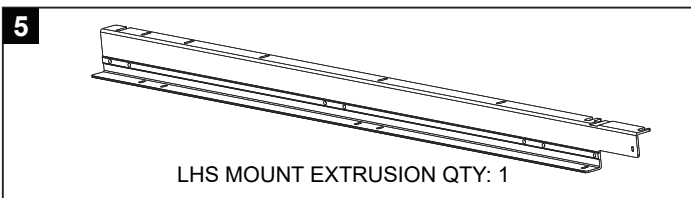
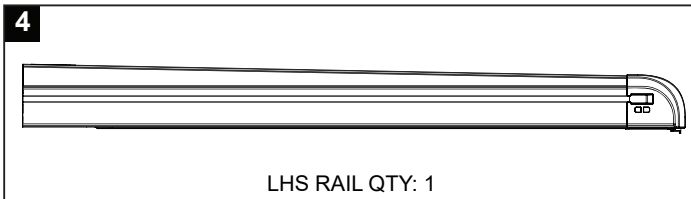
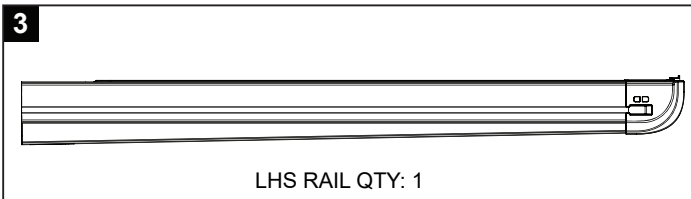
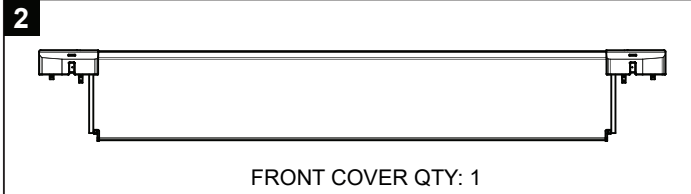
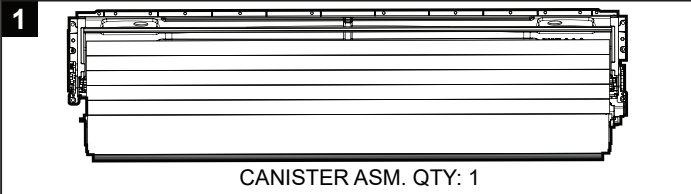

## EGR RollTrac M-Bar Assy Hardware Kit

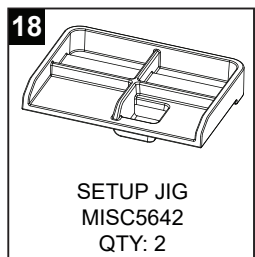
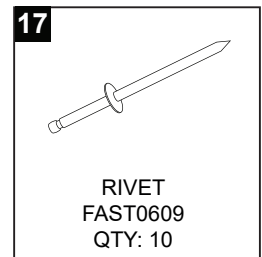
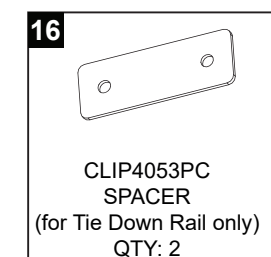
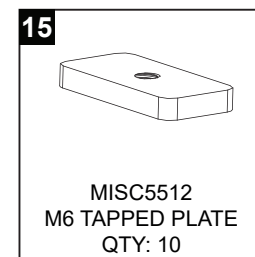
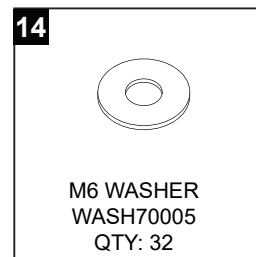
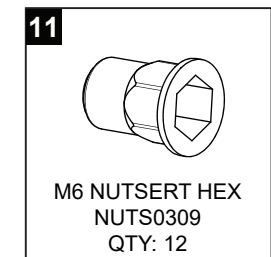
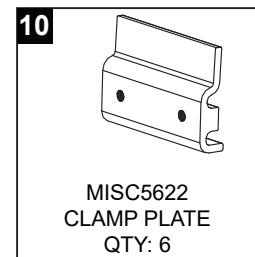
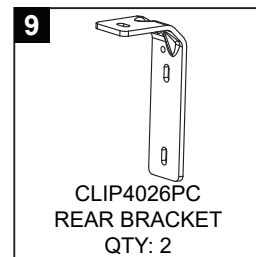
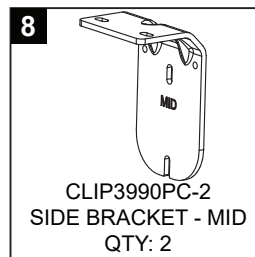
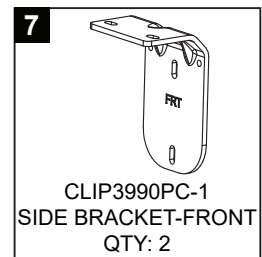

## EGR RollTrac FITTING KIT IN BOX

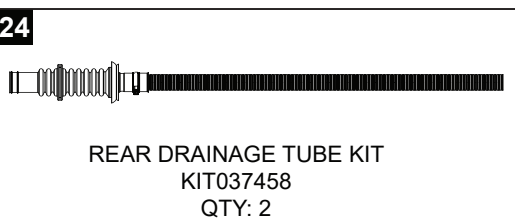
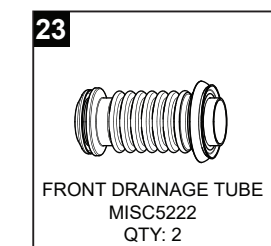
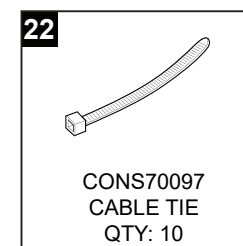
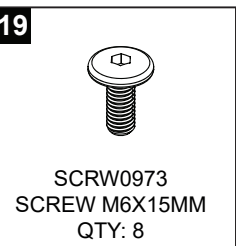

# EGR RollTrac FITTING KIT COMPONENTS IN BAGS

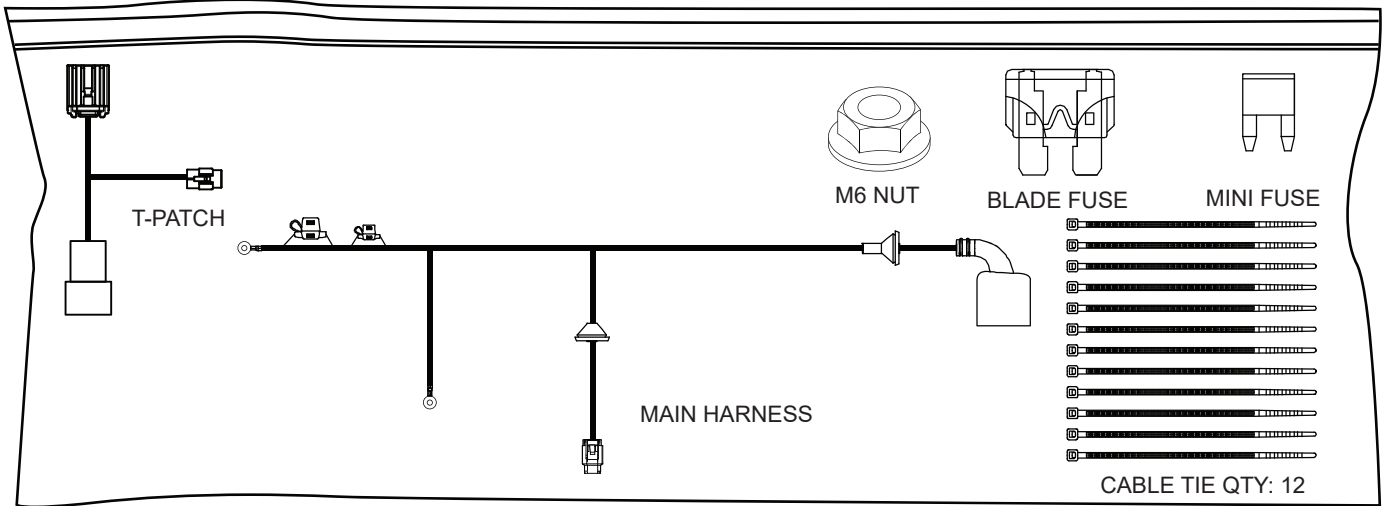

25

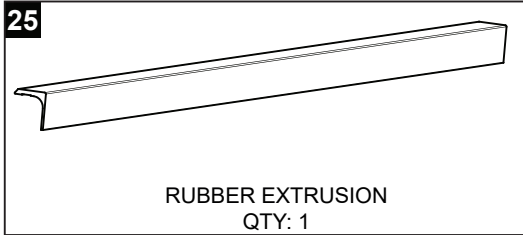

RUBBER EXTRUSION  
QTY: 1

## EGR RollTrac FITTING KIT ADDITIONAL ITEMS

26

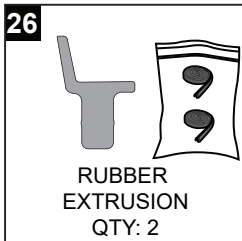

RUBBER  
EXTRUSION  
QTY: 2

INSTALLATION  
INSTRUCTIONS



OWNERS  
MANUAL

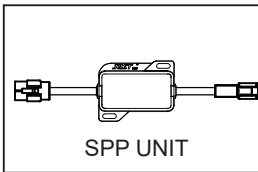

SPP UNIT



## TOOLS REQUIRED - NOT SUPPLIED IN KIT

Drill	Holesaw Ø29mm Ø38mm	Centre Punch & Hammer	Drill Stop Drill Bits Ø5.0mm	Scissors	Masking Tape Fiberglass Tape Black Cloth Tape
Ratchet & Sockets 7,10,13mm	Allen Key 4 & 5mm	Allen Key 2.5 & 4mm	Torque Wrench	Side Cutters	Soapy Water
50/50 Isopropyl Alcohol/Water	ANTI RUST Rust Inhibitor	Silicone	Anti-abrasion tape to seal holes & slots	Silicone Spray	Rivet Gun
METRIC Tape Measure	Ruler x2	3M Primer 94 (preferred) or equivalent	NUTSERT SETTING TOOL	<b>GLOSSARY:</b> <b>1</b> Number inside a square indicate part number <b>1</b> Number inside circle indicate the sequence within a step <b>1</b> Number inside the hexagon indicate torque instruction	



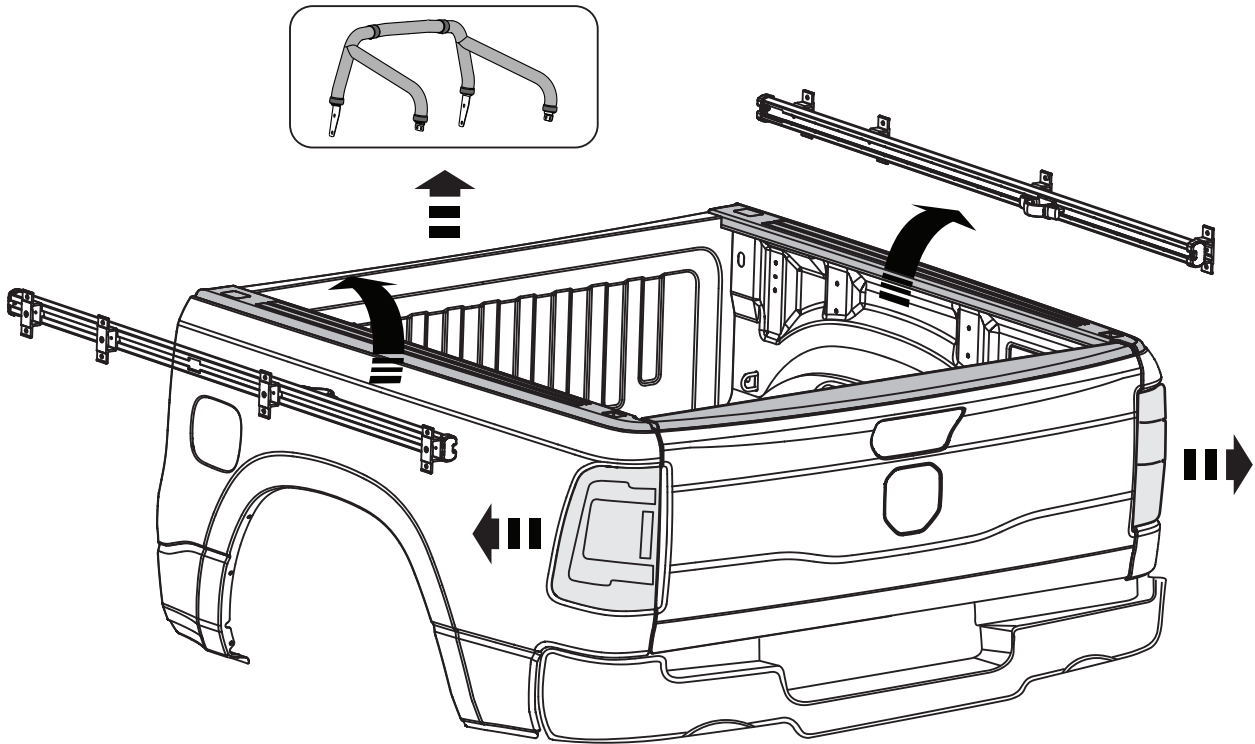

**1** Carefully remove any accessories (Sports Bars, Utility Rails, etc.) attached to the bed of the vehicle. Thoroughly wash the vehicle bed and ensure that all dirt and grease is removed. Allow to dry. Clean the top surfaces of the bed and tailgate and allow to dry. Carefully remove both Rear Tail Lamps with the appropriate tools and store in safe place. Retain all hardware for re-installation. **IMPORTANT:** Remove and retain Tie Down Rails (if fitted), discard screws.

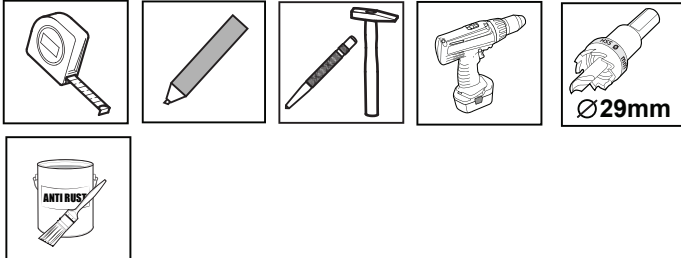

**HOLE FOR VEHICLE HARNESS  
LHS ONLY !**

**ATTENTION**  Ensure that the diameter of the hole does not exceed 29mm. Larger hole size will lead to water ingress into the bed

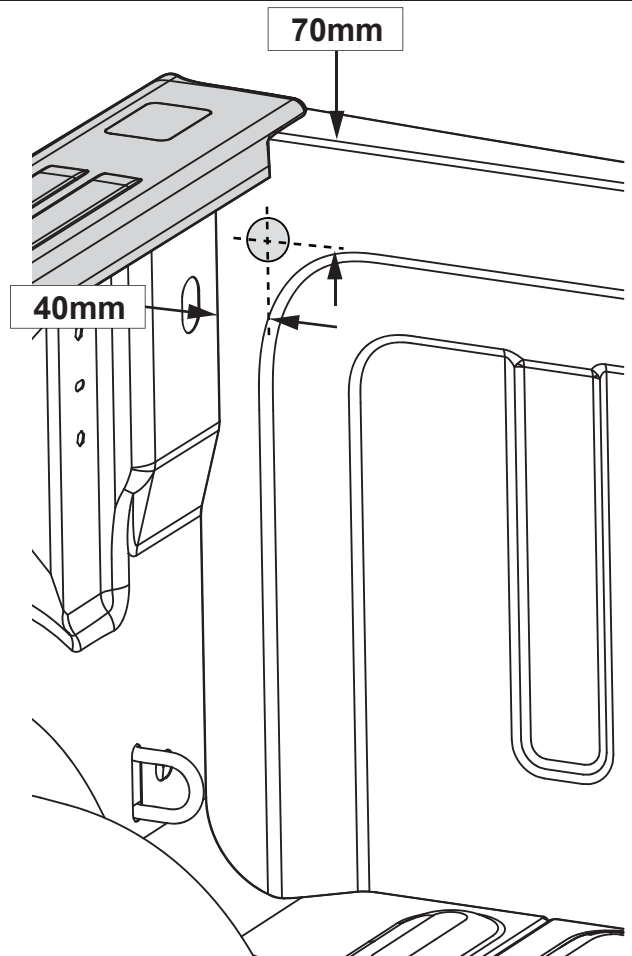

**2** On the front LHS of the bed, mark the position for the vehicle harness grommet and drill with 29mm holesaw. Clean all burrs and coat the exposed metal with a suitable rust preventative (not supplied).



### HOLES FOR FRONT DRAIN TUBES RHS & LHS



**ATTENTION** Ensure that the diameter of the hole does not exceed 38mm. Larger hole size will lead to water ingress into the bed

#### INSTALL FRONT DRAIN TUBES TO BED

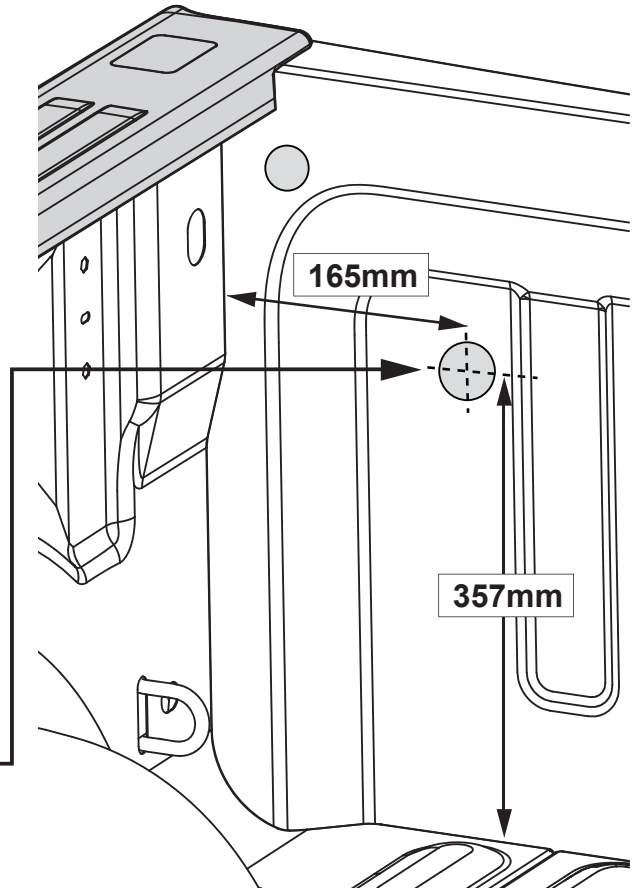
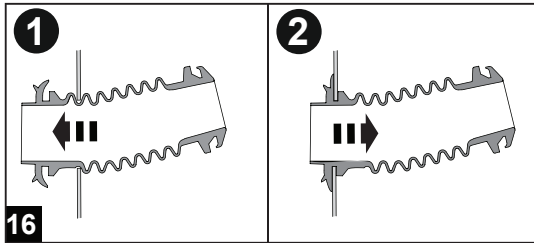

- 3** Mark the position of the front drain tube holes in the bed front panel and drill with 38mm holesaw. LHS shown, repeat on the RHS. Clean all burrs and coat the exposed metal with a suitable rust preventative (not supplied). Fit front drain tubes (16).



### HOLES FOR REAR DRAIN TUBES RHS & LHS



**ATTENTION** Ensure that the diameter of the hole does not exceed 29mm. Larger hole size will lead to water ingress into the bed

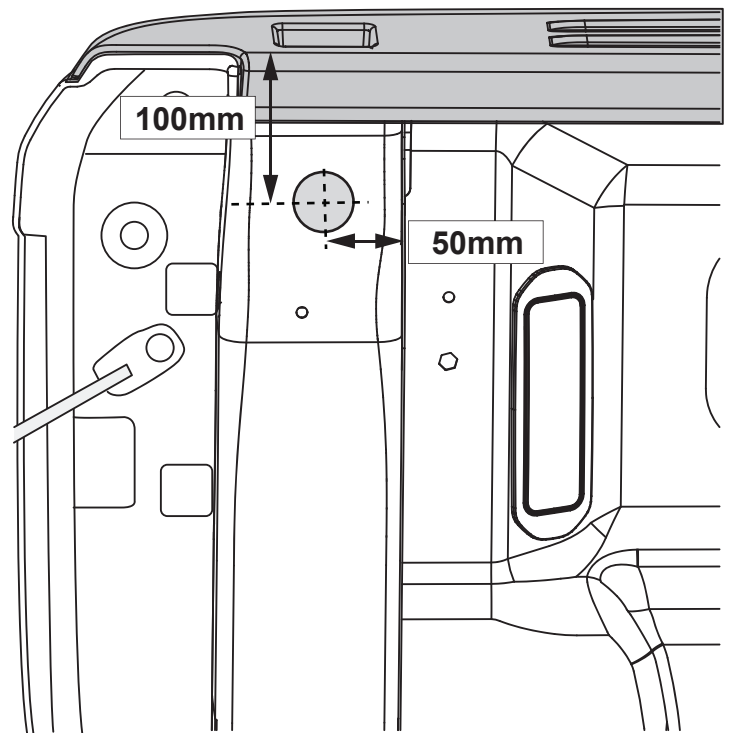

- 4** Mark the position of the rear drain tube holes in the bed rear panel and drill with 29mm holesaw. LHS shown, repeat on the RHS. Clean all burrs and coat the exposed metal with a suitable rust preventative (not supplied).

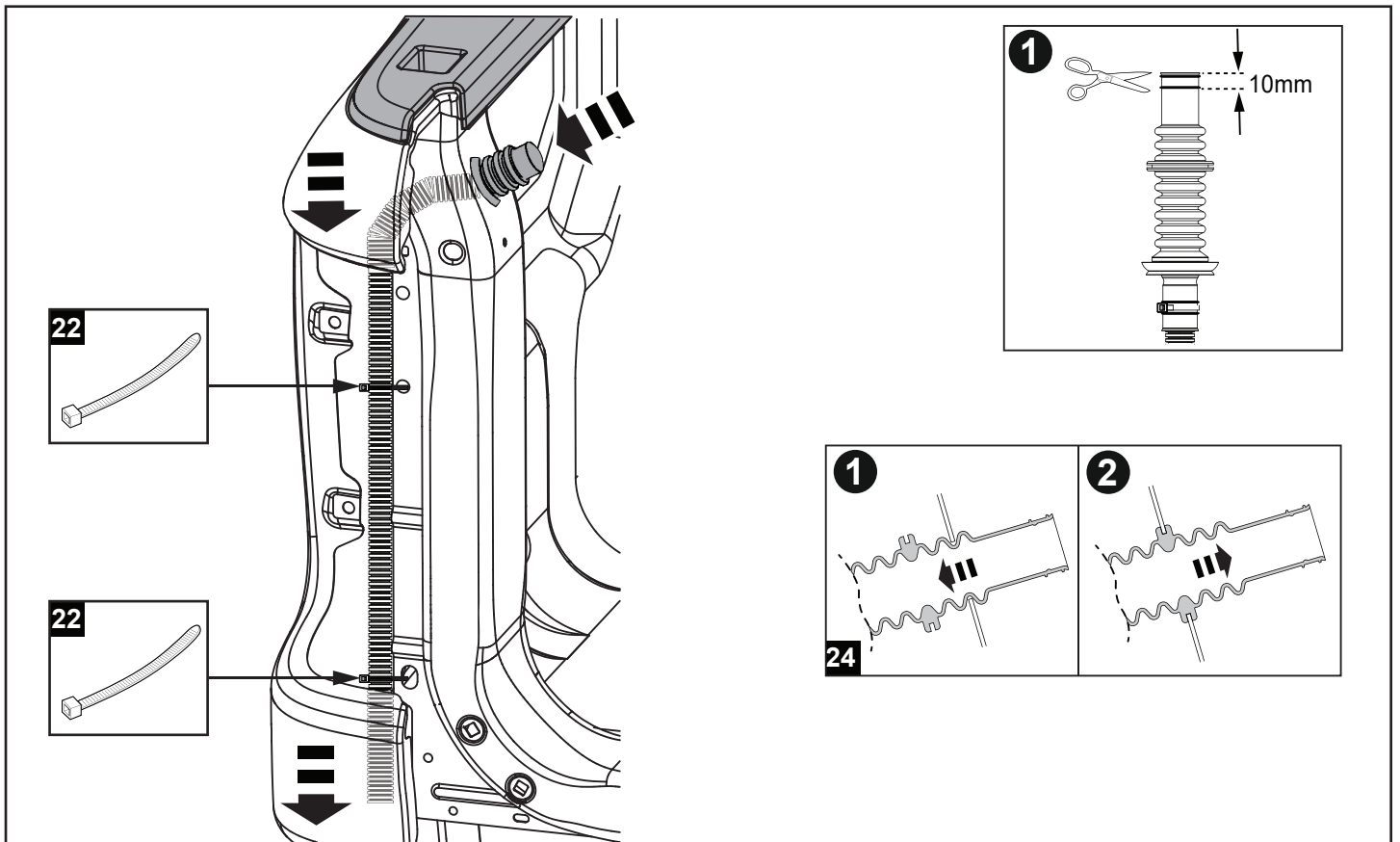

**5** Feed the rear drain tube into the drilled hole. Guide the plastic tube inside the tail light cavity towards the ground. Push the rubber tube in until it sits firmly in the hole. Secure the drain tube (24) to the sheet metal inside the tail light cavity using 2 cable ties (22). Refit Rear Tail Lamps.

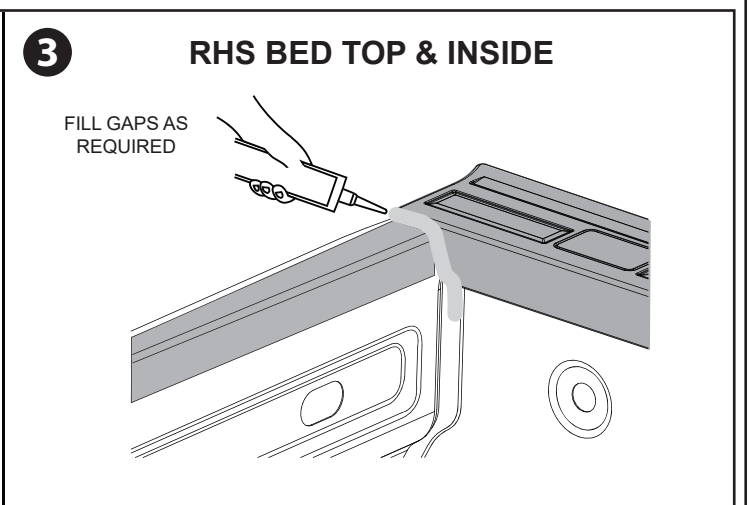
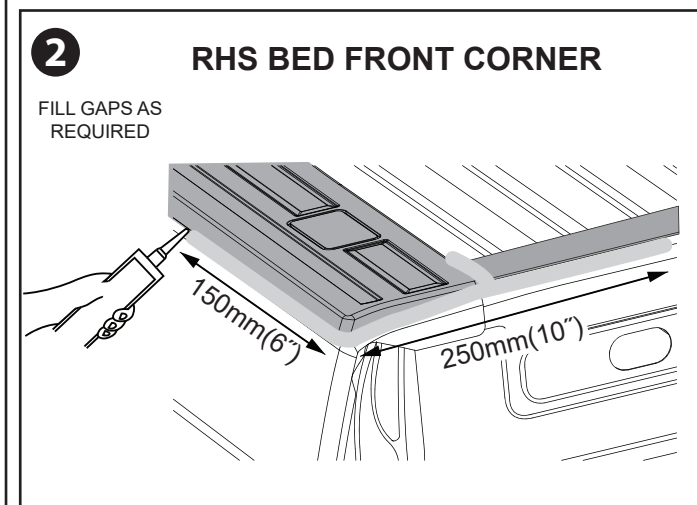
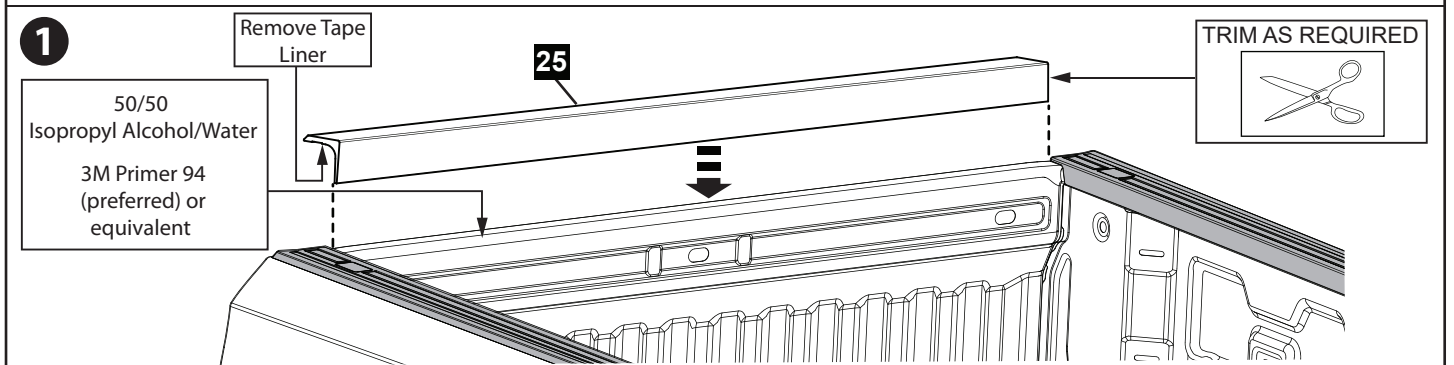

**6** Clean the front top of the bed using Isopropyl Alcohol/Water mix and apply primer to the top area. Allow to dry. Place the extrusion (25) on front of the vehicle bed, check the length and trim to full width if required. Pre-peel 50mm (2") of the tape liner from one end of the Rubber Extrusion (25). Place the Rubber Extrusion on top of the bed as shown and centralise. Once in position, peel the liner and apply firm pressure from the top. Silicone the gap between the panels as shown on both sides. NOTE: Holes in the bed should be sealed with Silicone to prevent dust and water ingress as required.

NUTSERT SETTING  
TOOL

11 x6

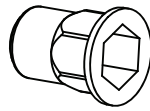

RHS

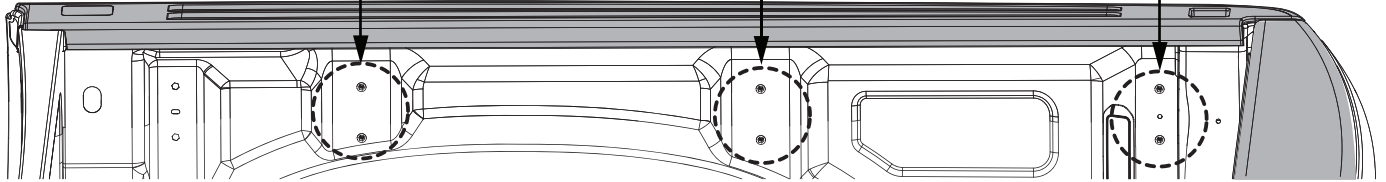

7 Check the six locations in the bed side wall for M6 nutserts (11). If not fitted previously, fit Nutserts on each side (provided) using suitable Nutsert setting tool.

RHS

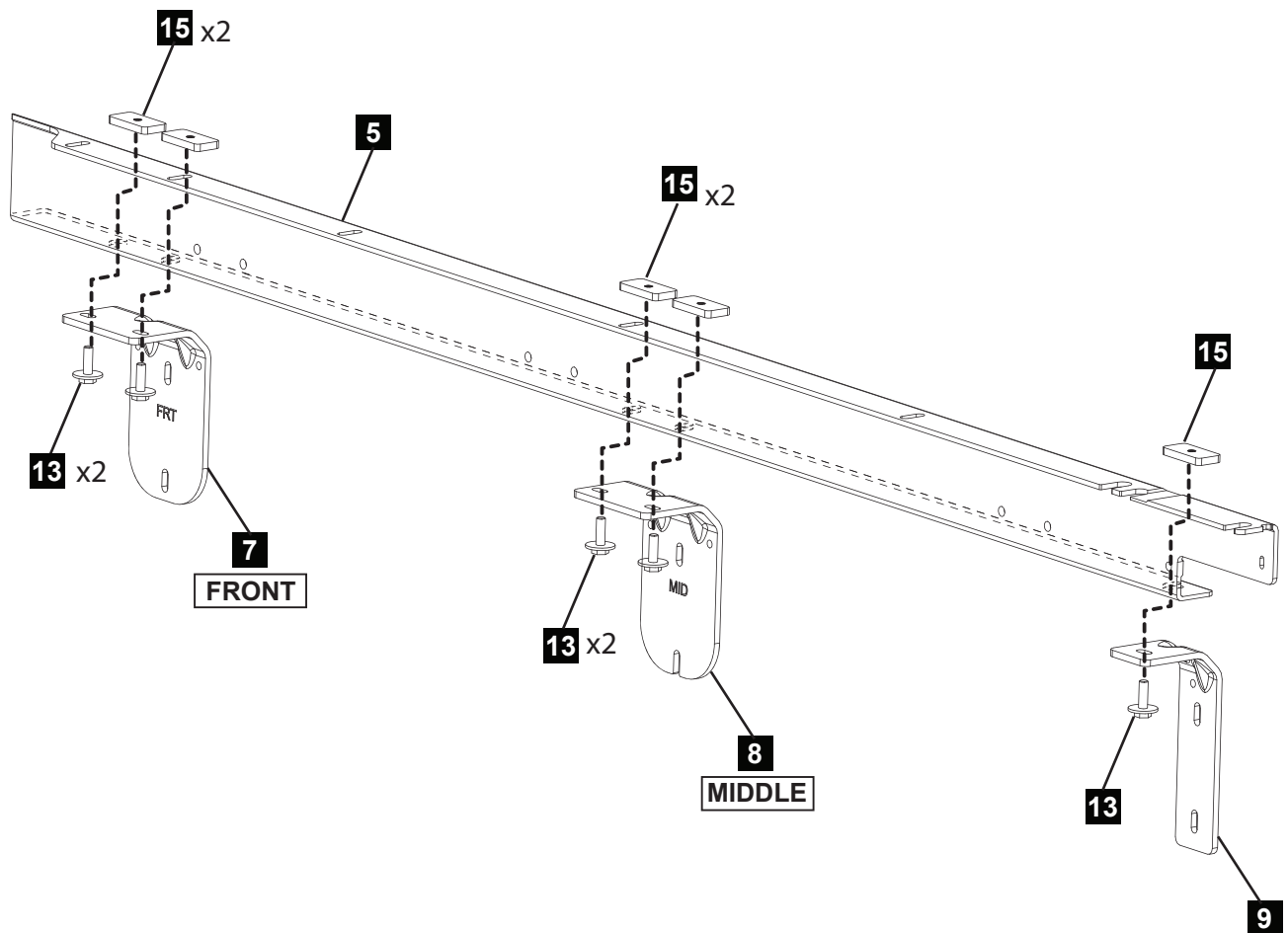

8 Fit the side brackets to the RHS mount extrusion as shown. Do not torque the screws at this stage.  
**IMPORTANT:** Side Brackets have markings: FRT (front) and MID (middle).

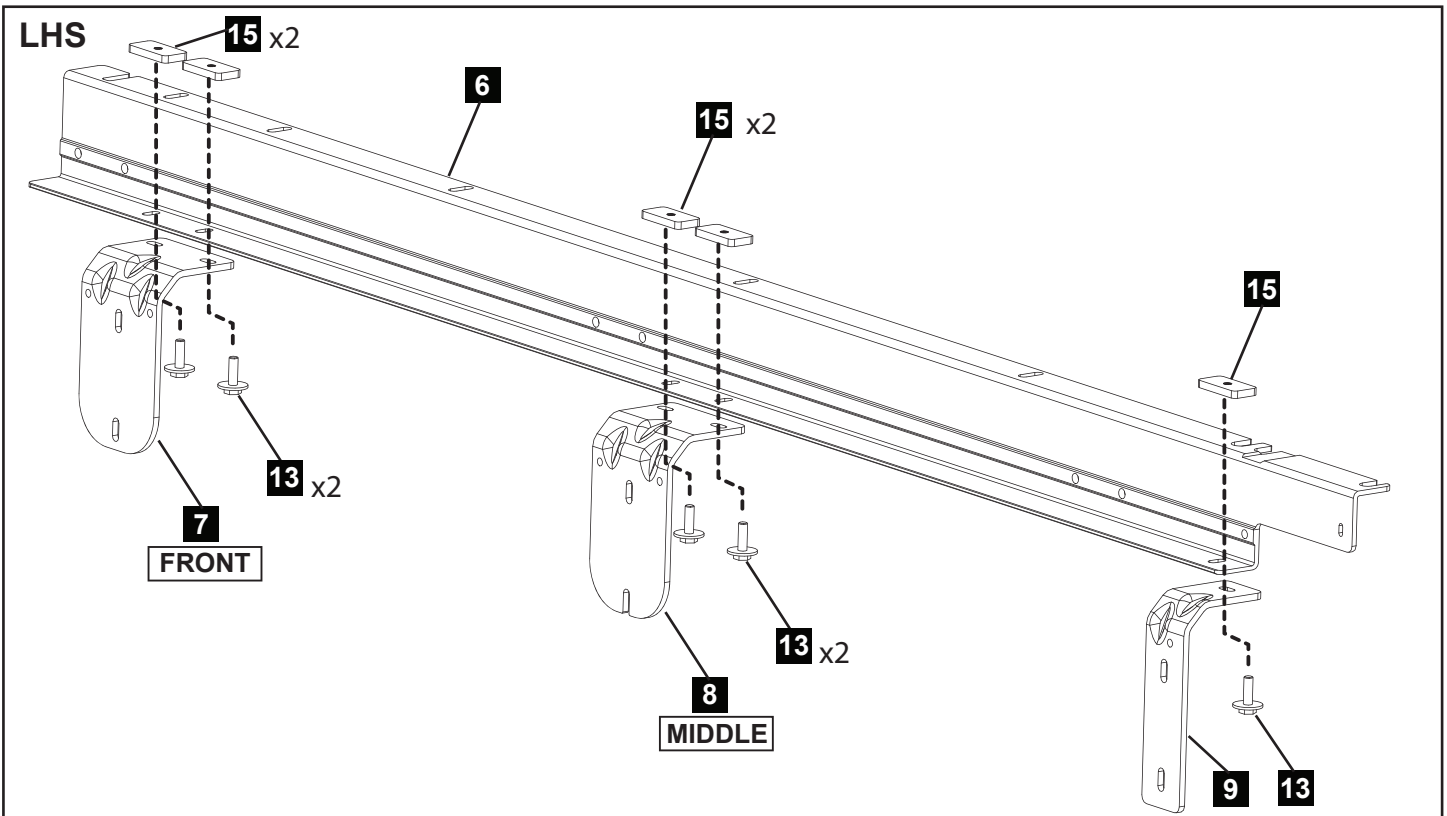

**9** Fit the side brackets to the LHS mount extrusion as shown. **NOTE:** Do not torque the screws at this stage. **IMPORTANT:** Side Brackets have markings: FRT (front) and MID (middle).

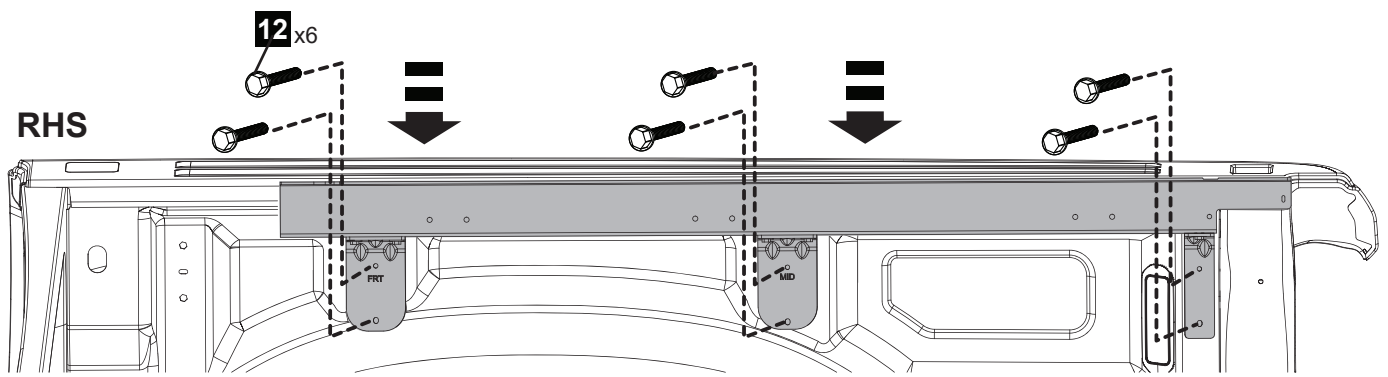
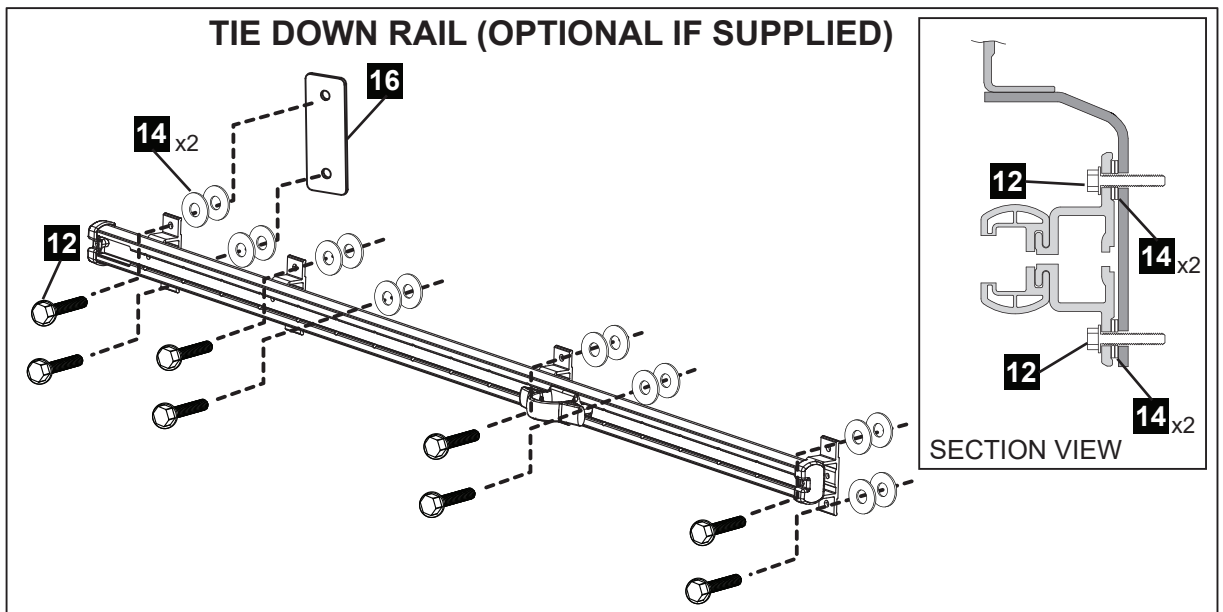
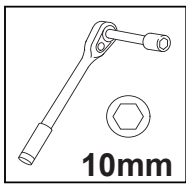

**10** Fit the mount extrusion to the inside of the bed. Secure loosely to the nutserts with M6 screws (12). **NOTE:** Fit the Tie Down Rail at the same time if supplied and use the spacer (16) at the front location as shown, and two washers (14) per screw between Tie Down Rail and mounting bar support brackets.

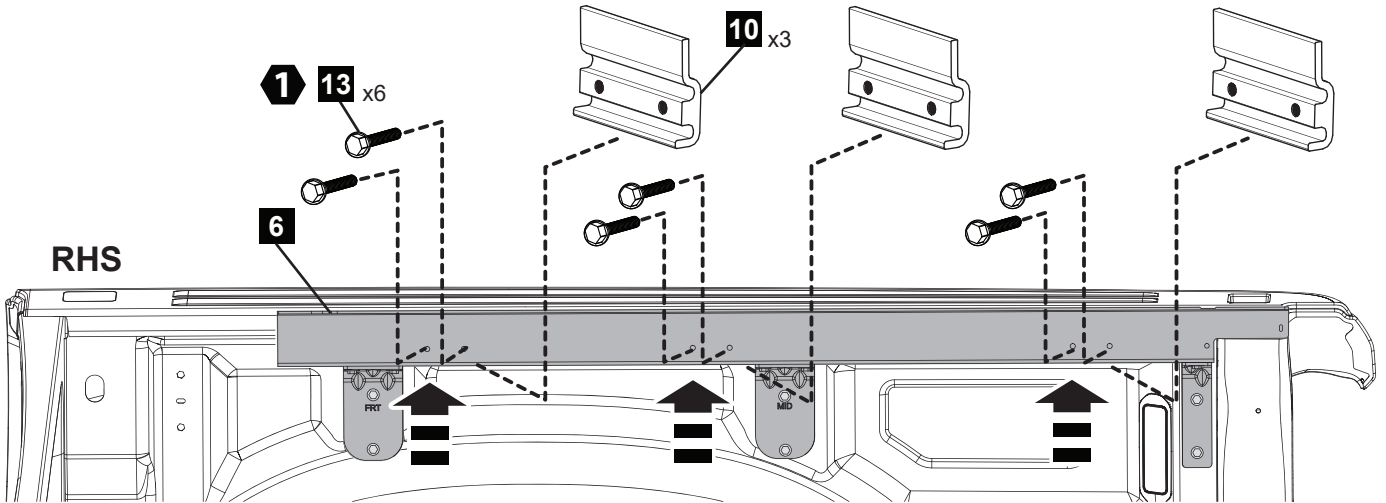
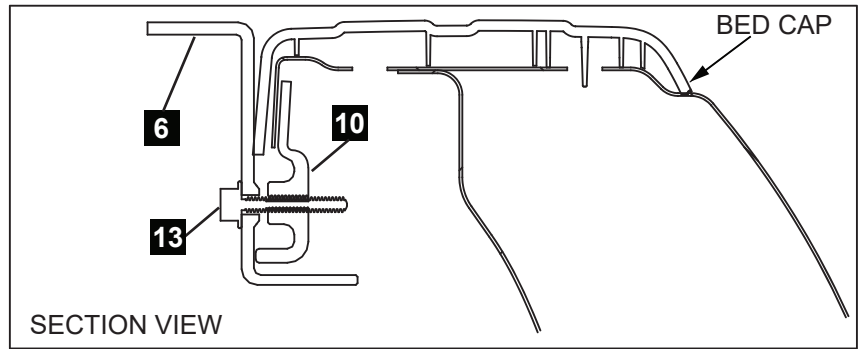
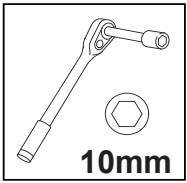

**11** Fit the clamp plates (10) inside the bed as shown in the detail and loosely secure with screws (13).

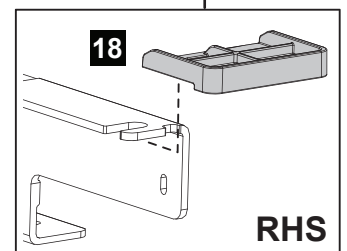
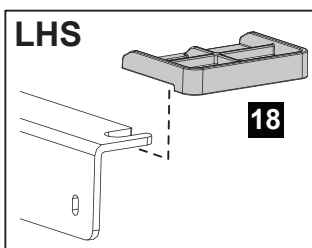
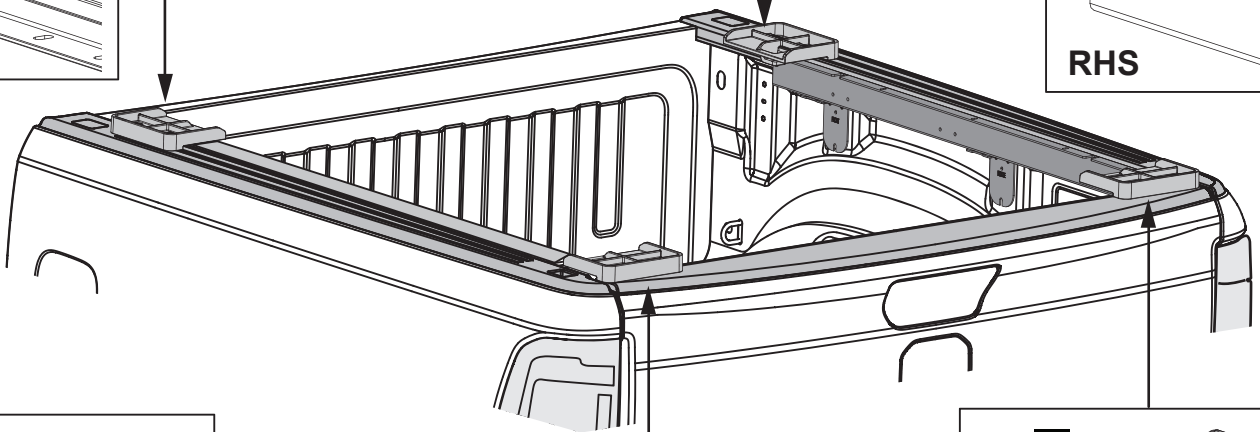
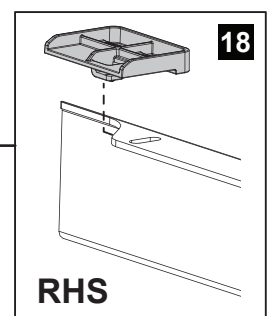
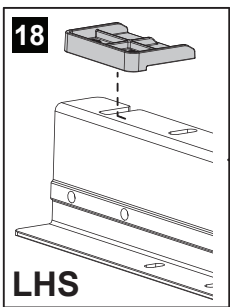

**12** Fit the setup jigs to set up the RH mount extrusion first. Adjust the mount extrusion front position to the bed cap and rear position to the top of the tailgate using the setup jigs as a guide. Details as follows.



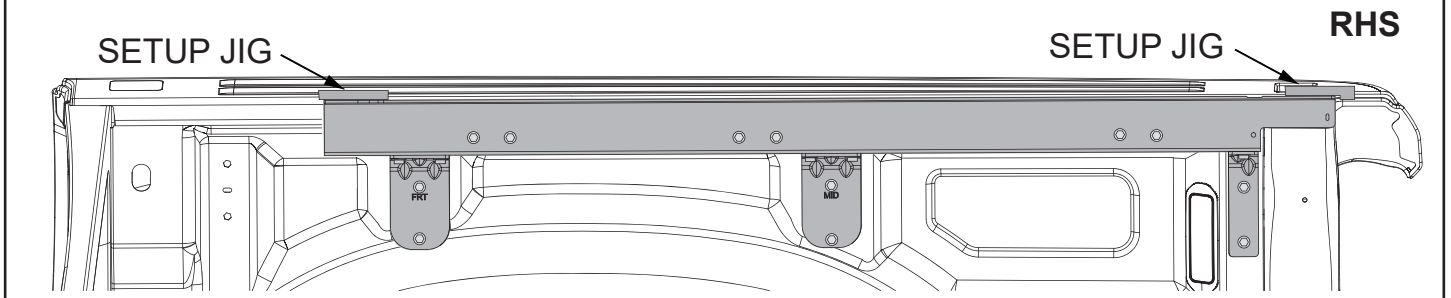
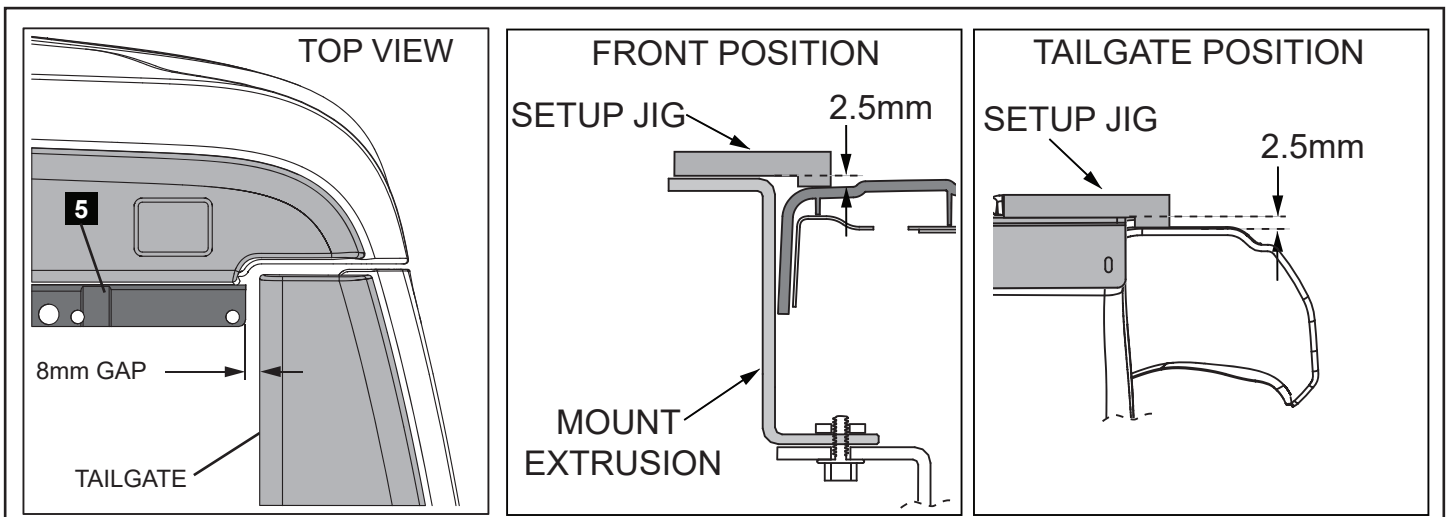

**13** Set front/back position of the mount extrusion relative to the tailgate (8mm gap) as shown in top view. Set the vertical position of mounting extrusion by adjusting the extrusion relative to the bedcap (ensuring parts are held level). Use the setup jigs to achieve a 2.5mm step between the front end of the extrusion Vs bedcap; and a 2.5mm step between the rear end of extrusion Vs tailgate - as shown in detail views above.

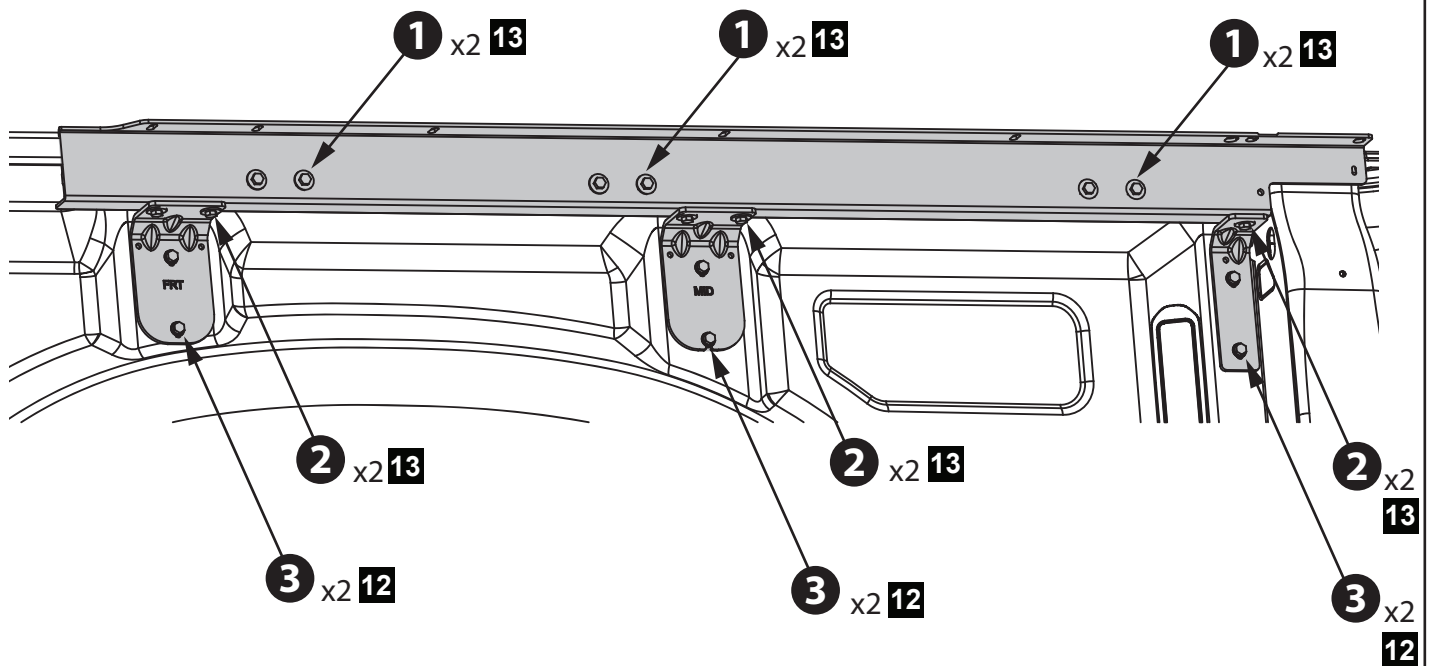
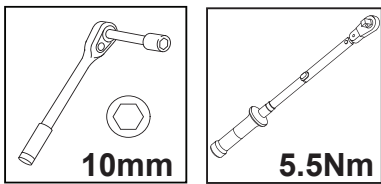

**14** Torque all screws 12 & 13 to 5.5Nm in order shown above. Recheck mounting extrusion position from step 13 and remove setup jigs. Repeat step 12-14 on LH side.



SECTION B

ELECTRICAL LOOM INSTALLATION



WHILE ROUTING THE VEHICLE HARNESS AVOID ANY VEHICLE COMPONENTS THAT HEAT UP, LIKE EXHAUST AND ENGINE COMPONENTS. DO NOT ATTACH HARNESS TO FUEL LINES AND AVOID PINCH POINTS.

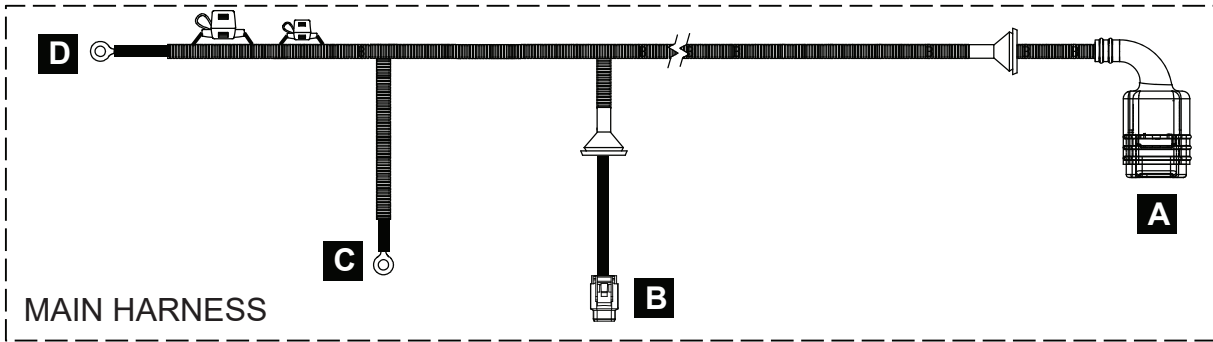

MAIN HARNESS

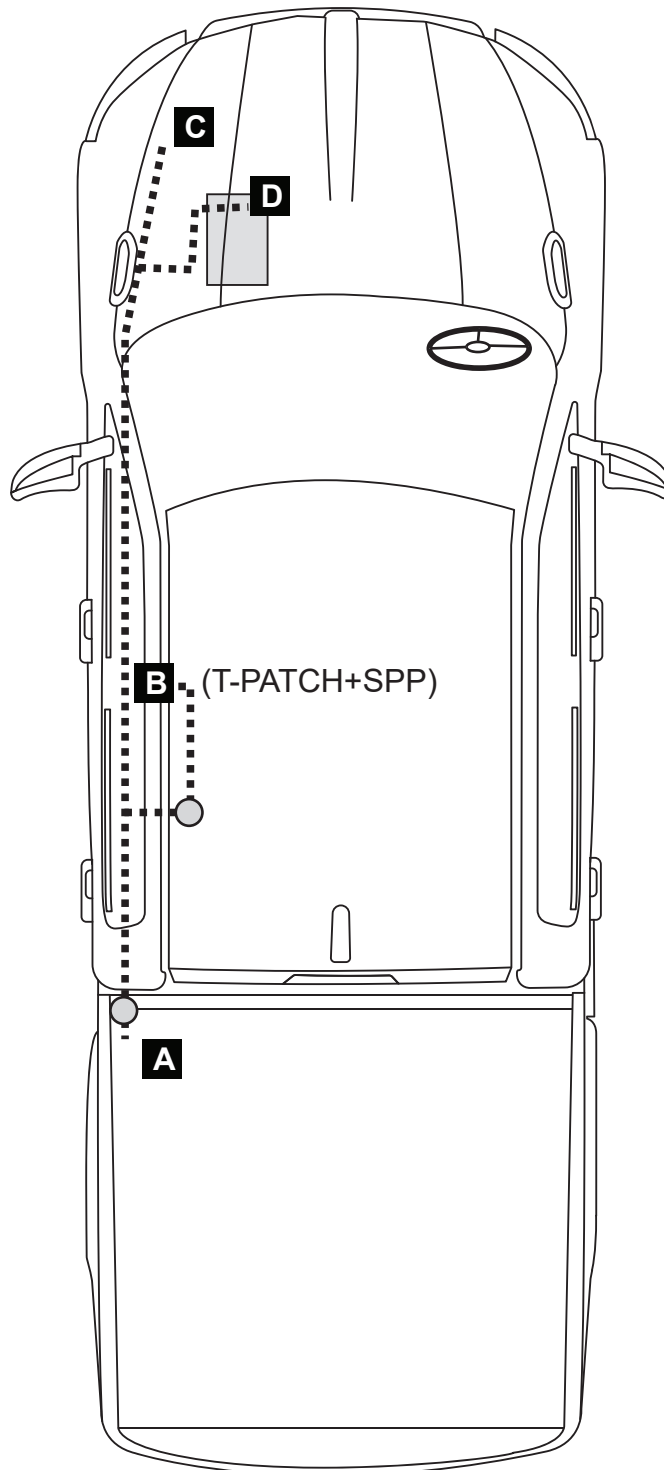

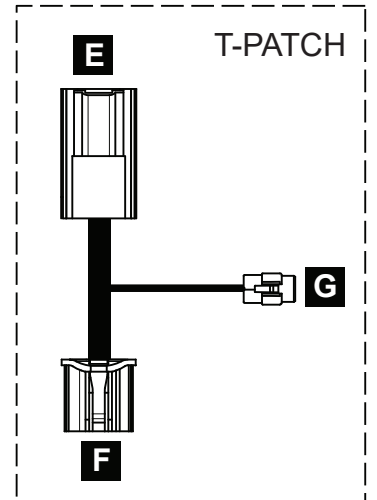

TOP VIEW

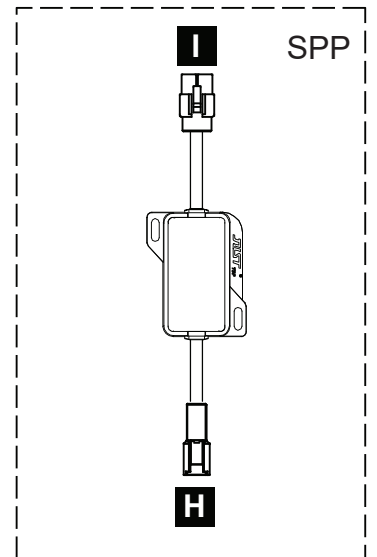

T-PATCH



SPP

 FOR VEHICLES WITH ELECTRIC / RETRACTABLE SIDE STEPS ONLY  
FAILURE TO DISCONNECT MAY RESULT IN SERIOUS INJURY 

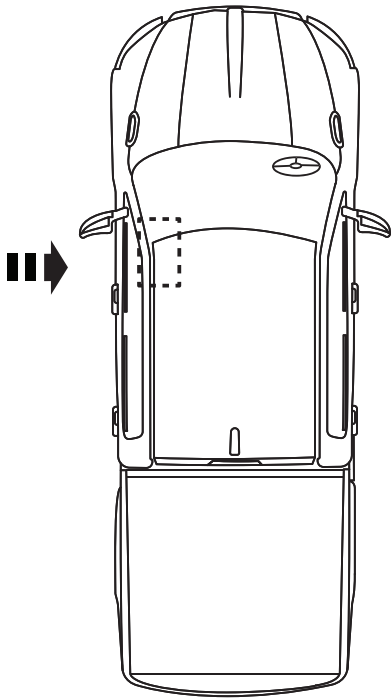

**TOP VIEW**

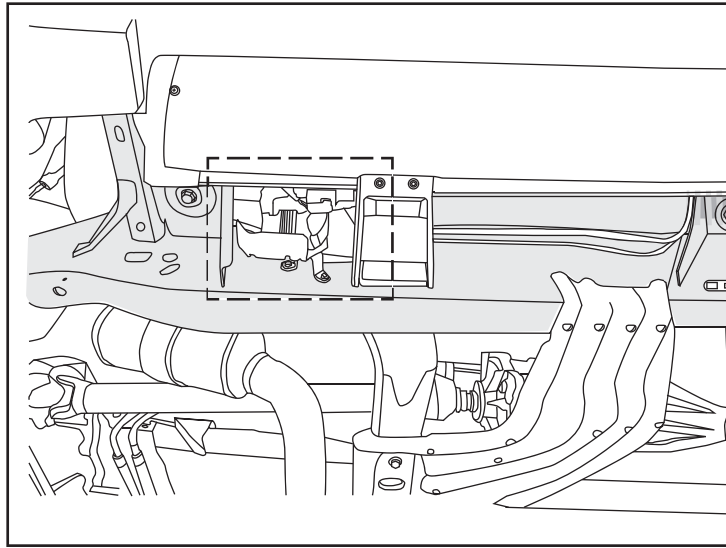

**DISCONNECT**



- 1** Close all doors. Wait at least 10 seconds for the step to fully retract. Head under the front left hand side of the vehicle and detach the LHS side step motor connector. At all times, keep hands and appendages clear of the motorized step. Failure to disconnect may result in serious injury.

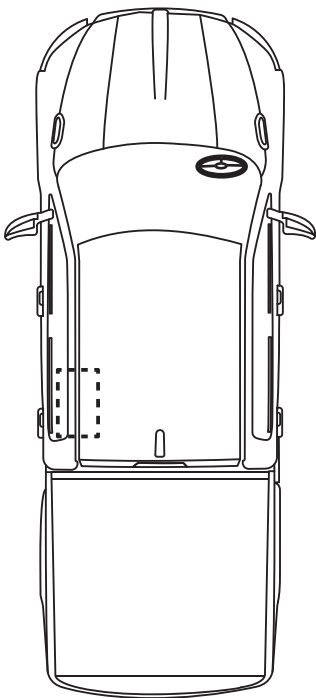

**TOP VIEW**

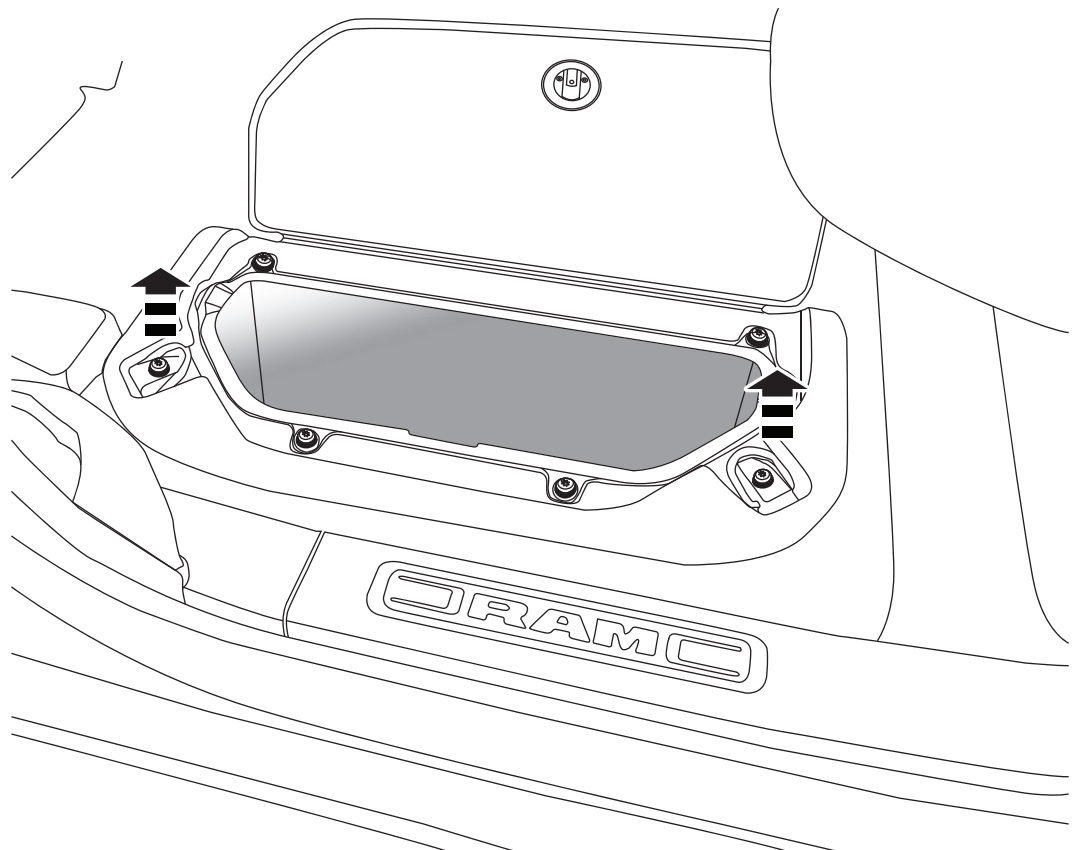

- 2** Remove plastic container liner. Lift plastic covers as shown by the arrows to expose 2 Torx screws. Remove all 6 Torx screws and remove the lid and box out from the floor.

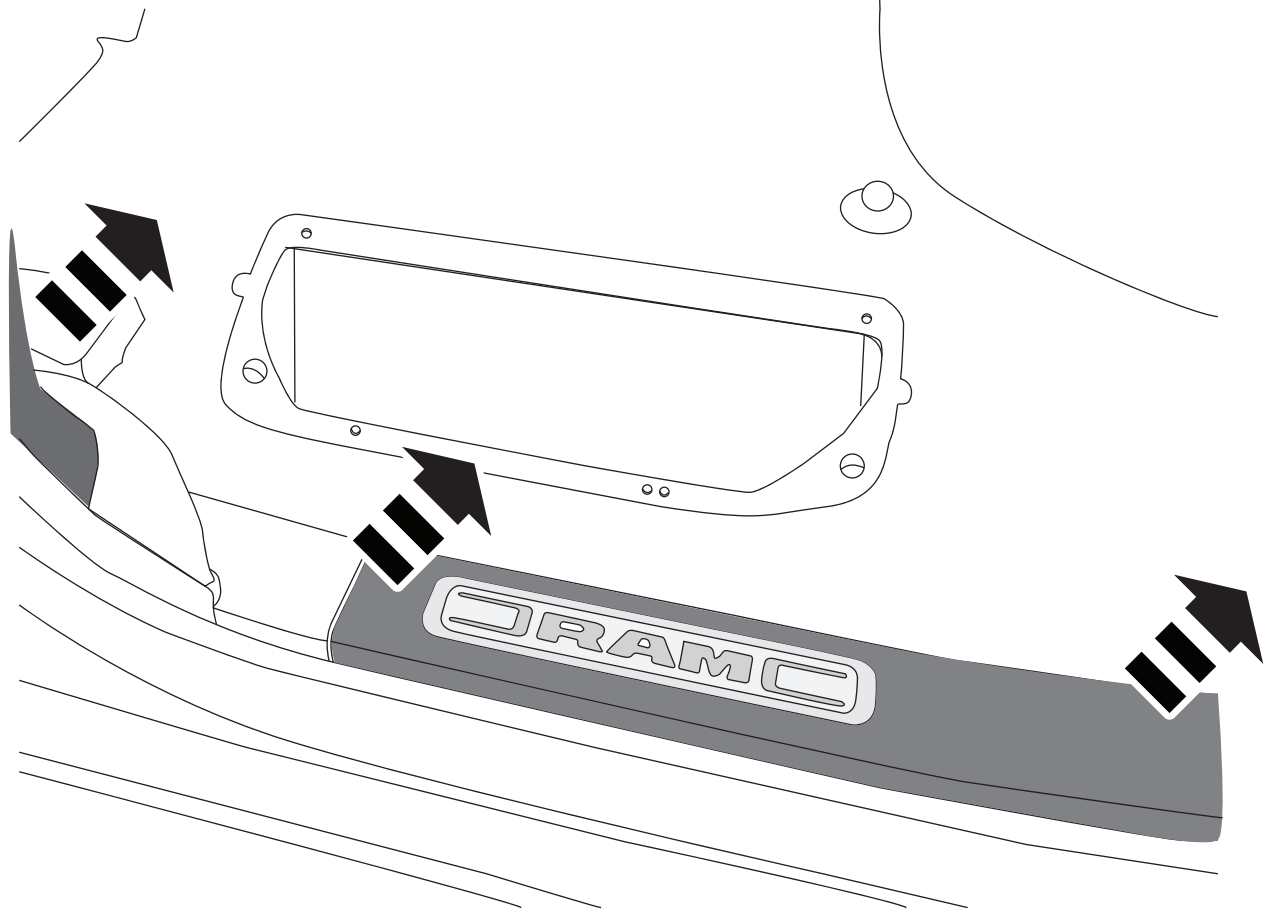

**3** Remove scuff plate and upper B-pillar panel to expose the carpet and seat belt assembly respectively.  
 NOTE: Leave the Lower B-pillar trim panel attached as there is no requirement to remove.

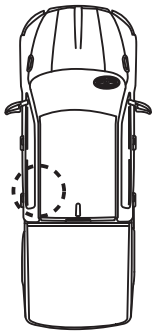

**TOP VIEW**

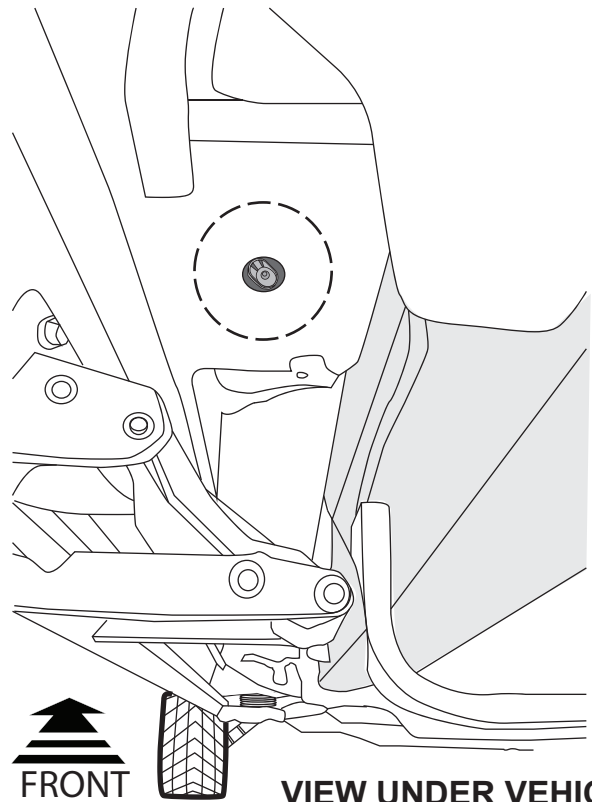

**FRONT**

**VIEW UNDER VEHICLE**

**4** Note: The chassis floor plug is glued to the chassis. To dislodge floor plug, apply upwards impact force with a hammer from underneath the vehicle floor.

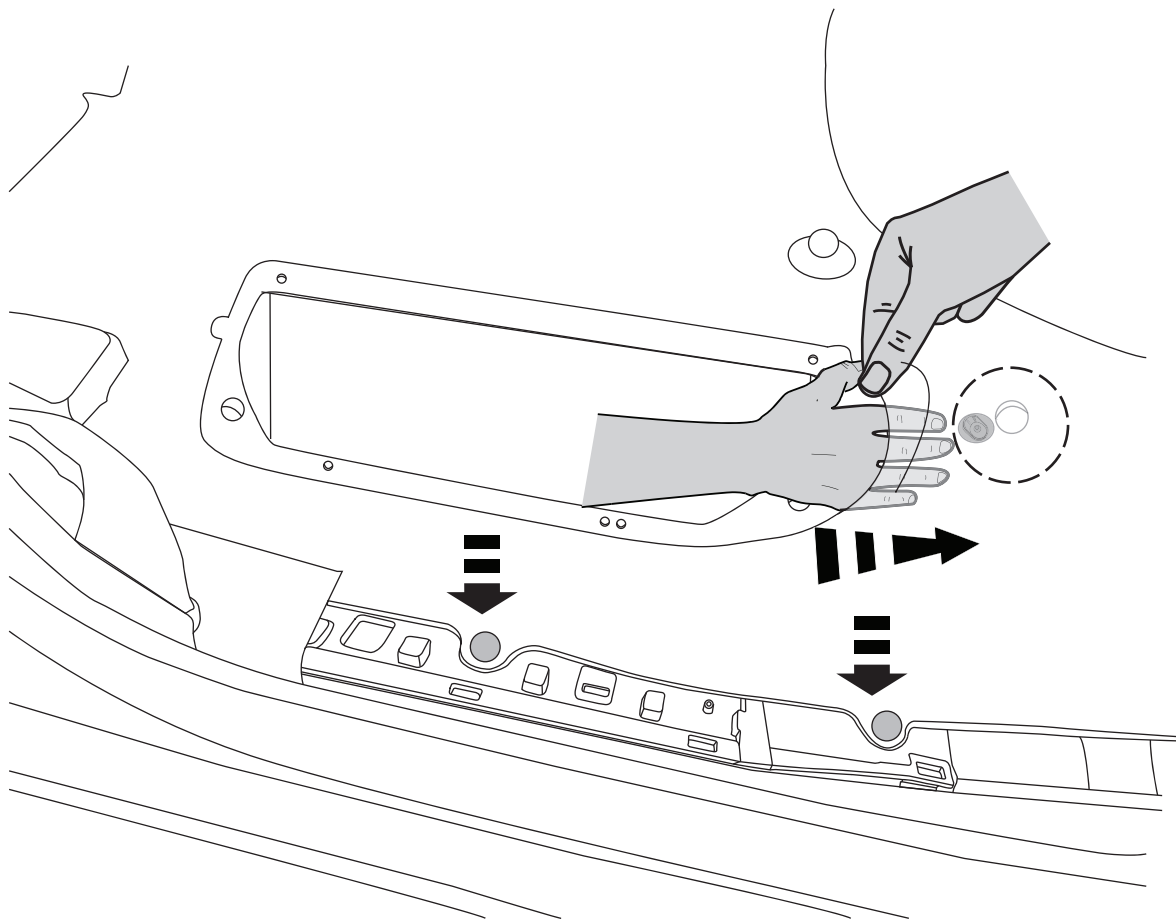

**5** Remove Carpet Clips as shown. Lift carpet and reach hand under to retrieve chassis floor plug.

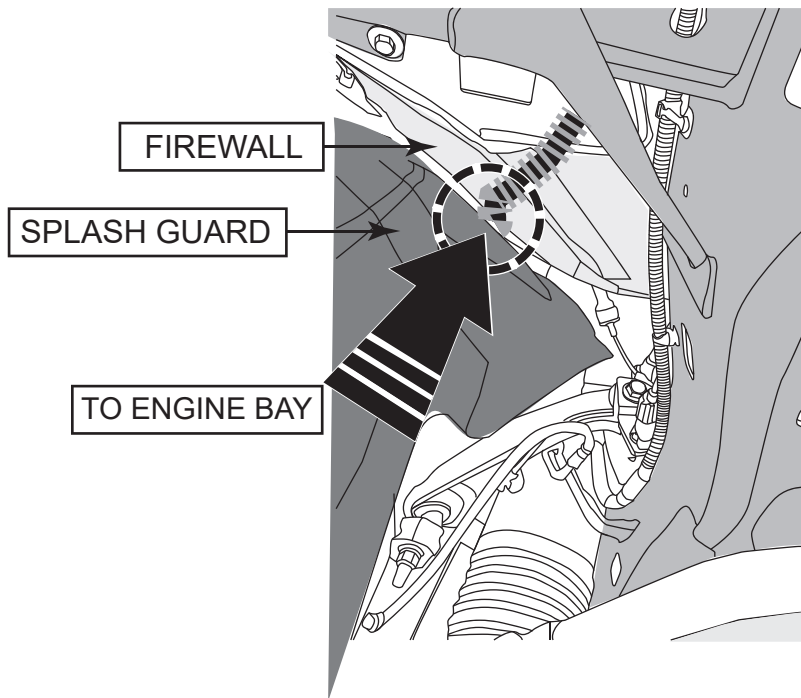
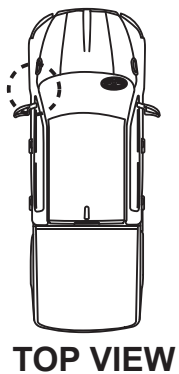

**VIEW UNDER VEHICLE**

**6** Feed pull wire from the top of the engine bay, behind the battery, between the plastic splash guard and firewall. Attach connectors D and C to the pull wire and pull back up between the plastic splash guard and firewall.

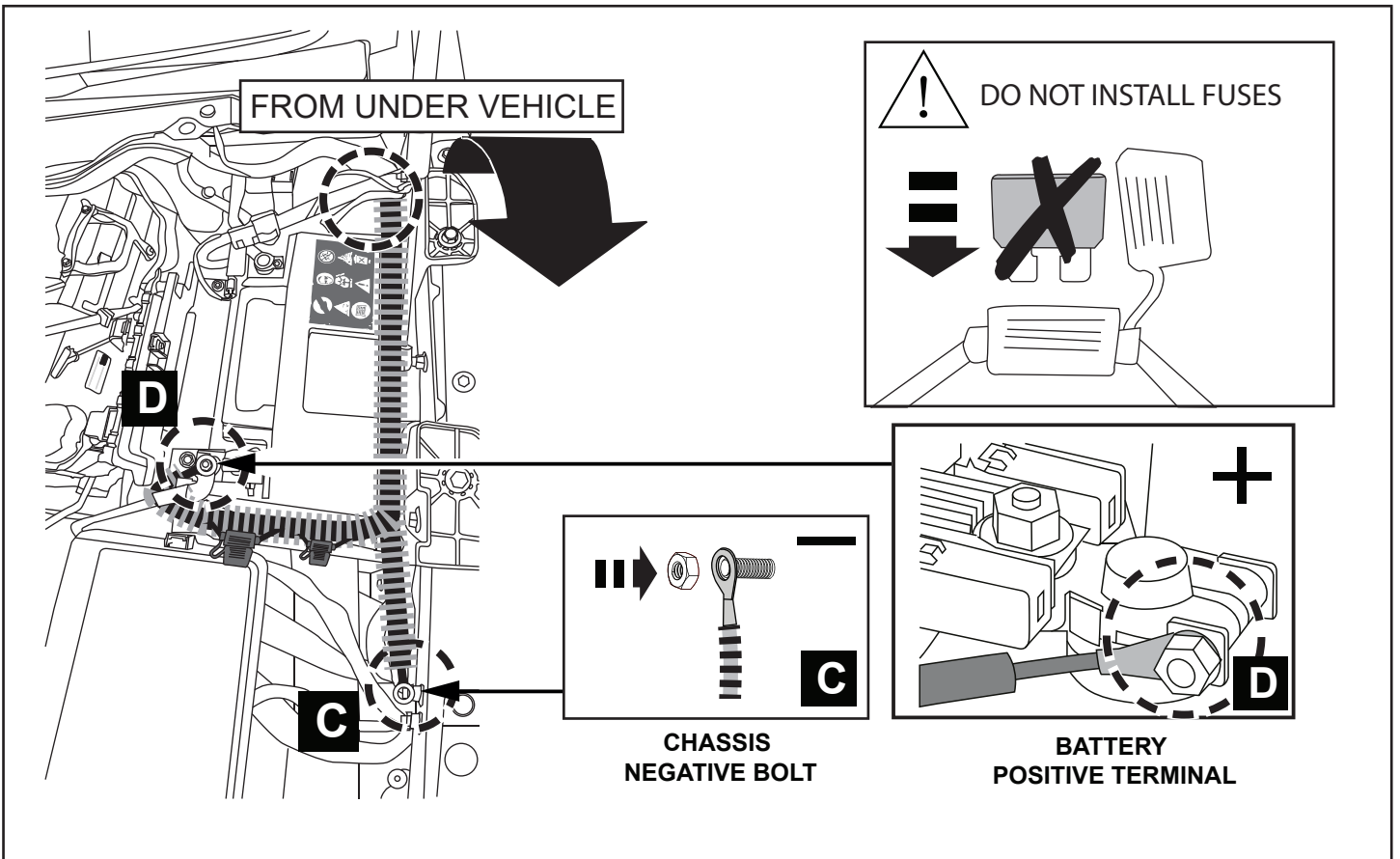

**7** Before connecting, ensure the two fuses are removed from the positive wire in-line fuse housing. Do not install any fuses until instructed. Lift the positive terminal cover to allow installation of the harness positive ring terminal. Ensure installation of positive ring terminal allows for positive terminal cover to be reinstalled. Connect Positive Ring Terminal (D) to the second positive terminal and connect Negative Ring Connector (C) to the first negative chassis stud as shown.

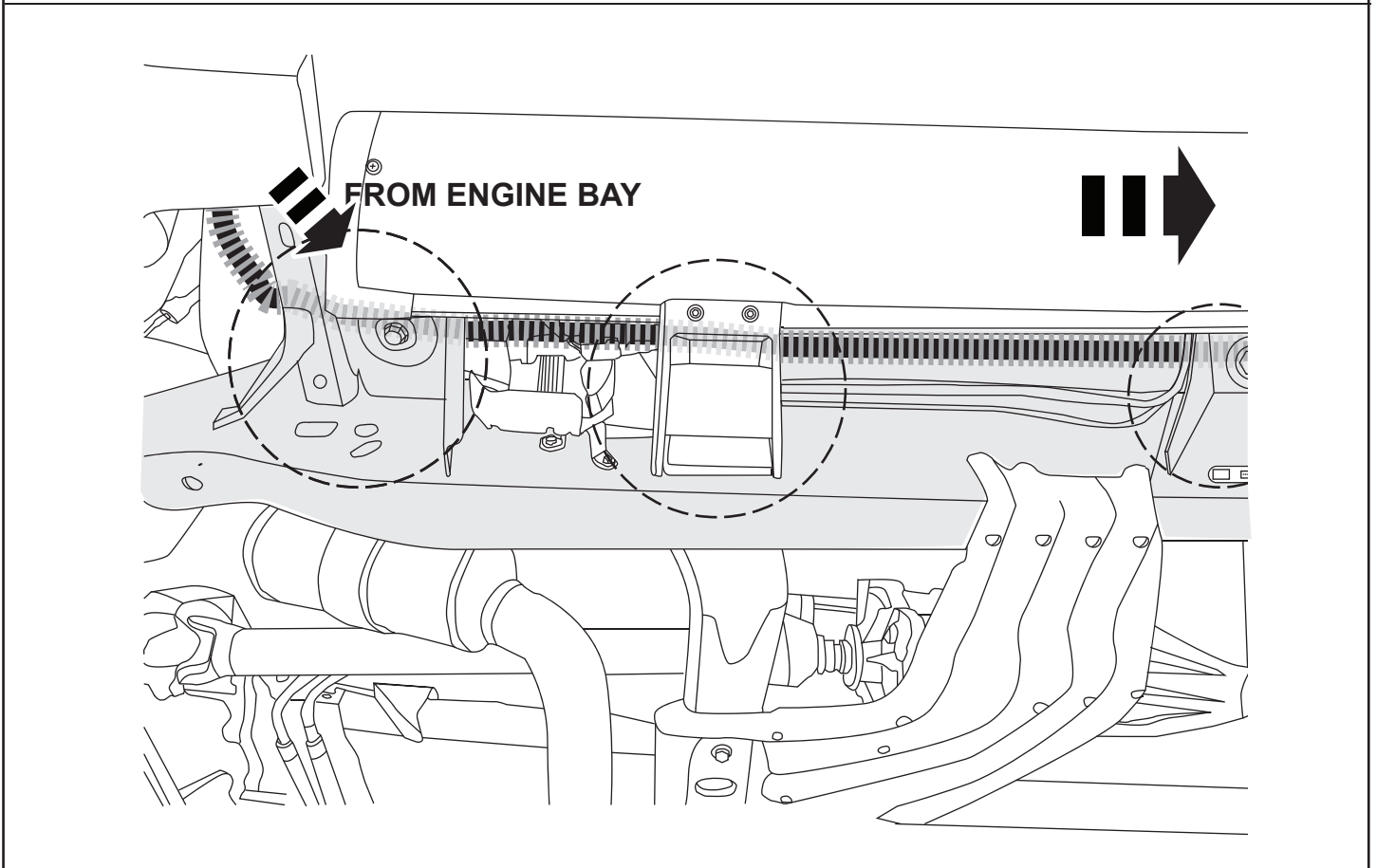

**8** Vehicle Harness will follow chassis rail. Zip tie Vehicle Harness at top towards rear. Ensure to zip tie above and behind any vehicle support structures as circled.

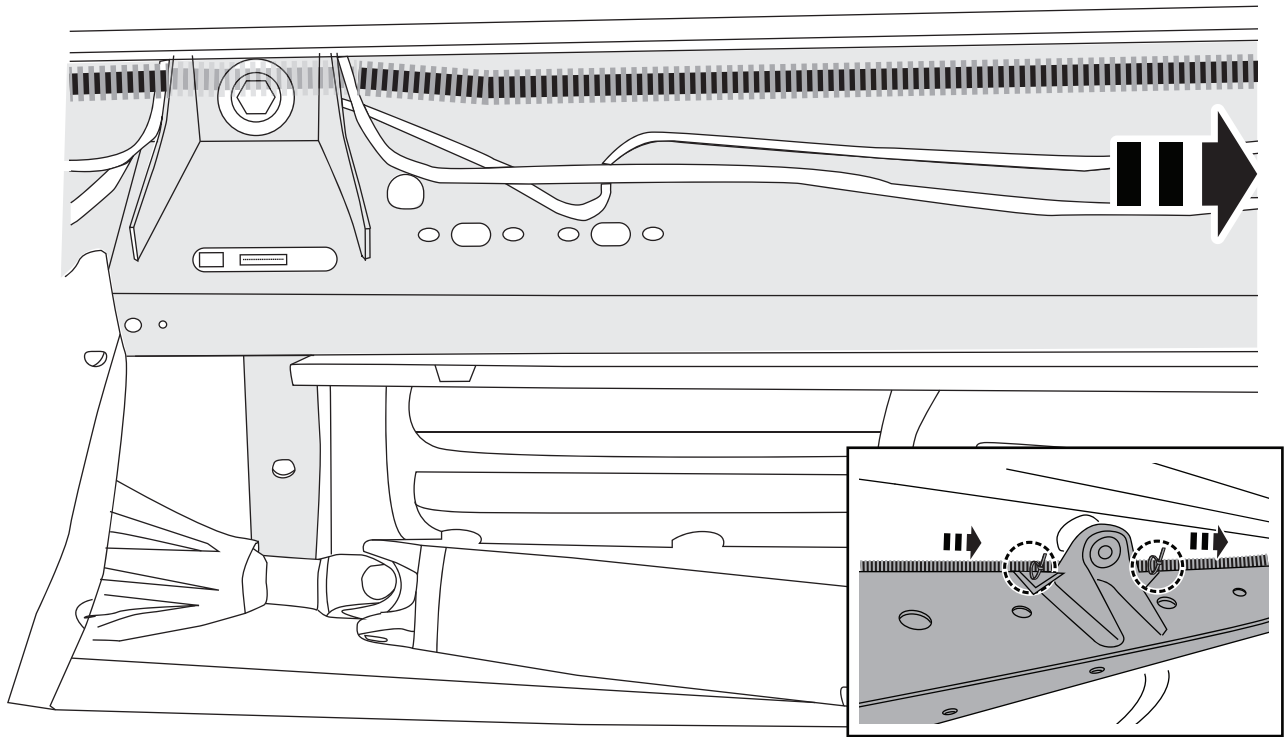

- 9** Vehicle Harness will follow chassis rail. Zip tie Vehicle Harness at top towards rear. Ensure to zip tie above and behind any vehicle support structures as shown.

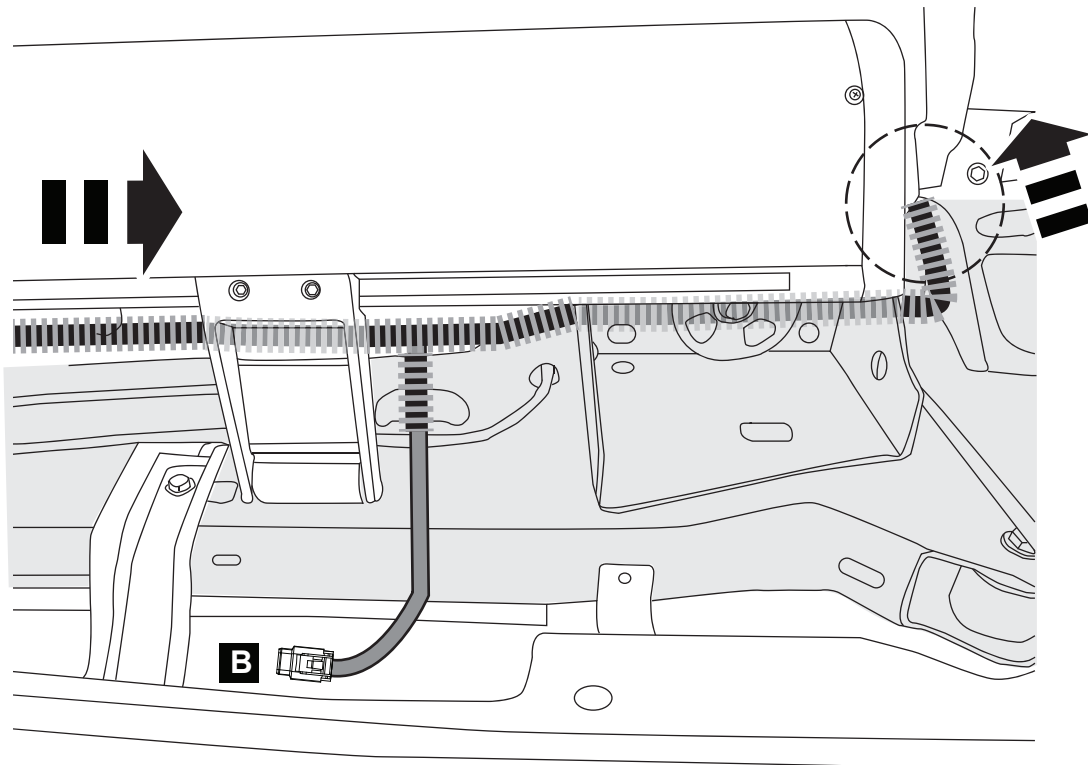

- 10** The Vehicle harness should have a T intersection approximately located where the glued chassis floor plug was removed. At the T intersection, let Connector B hang loose, and continue running the Vehicle Harness (Connector A) towards the rear, to the gap between the vehicle cab and bed.

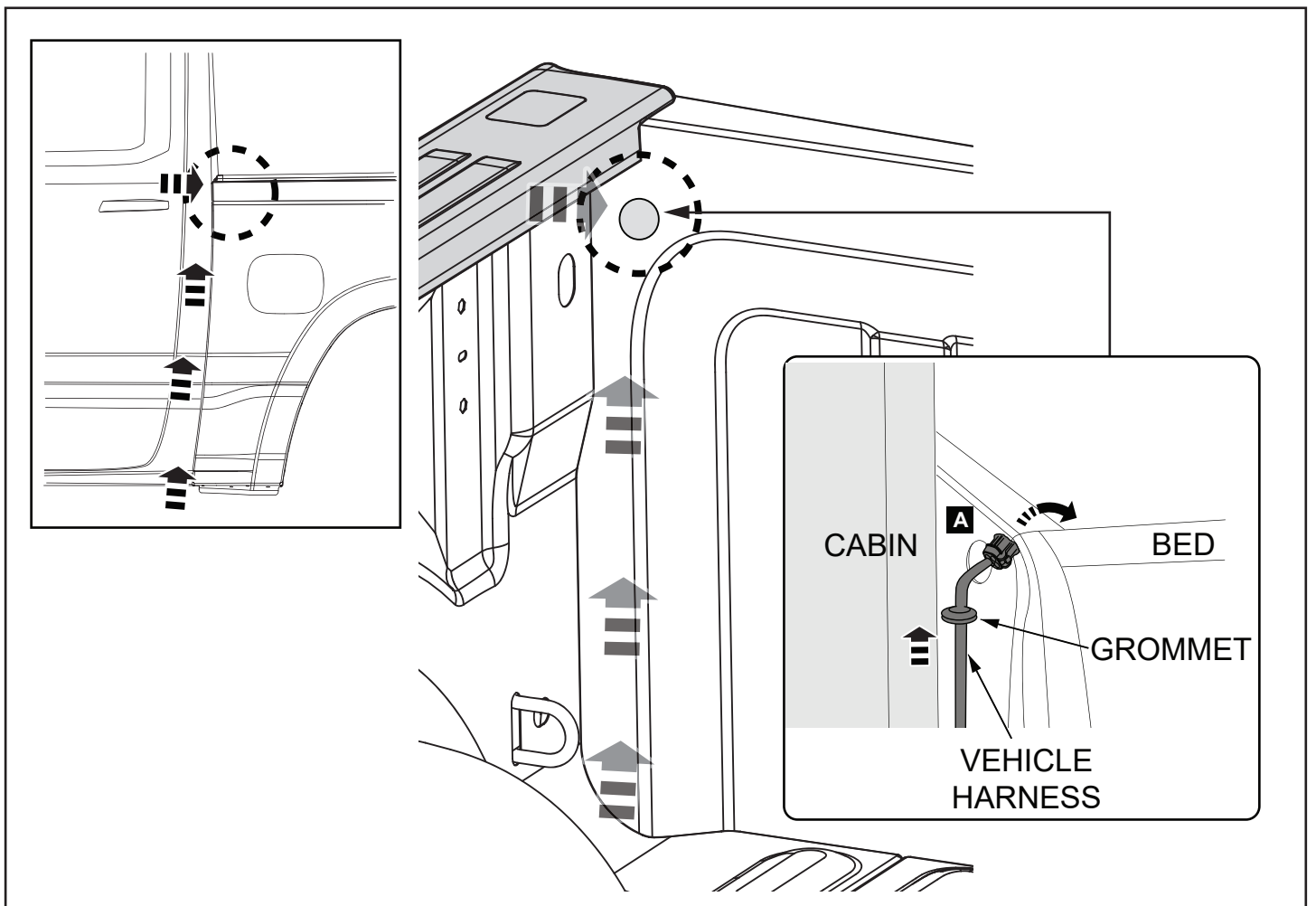

- 11** Run the rear most end of the Vehicle Harness (Connector A) up in between the cab and the bed up to the hole. Pull Vehicle Harness and Connector A through hole and ensure grommet fits and seals hole.

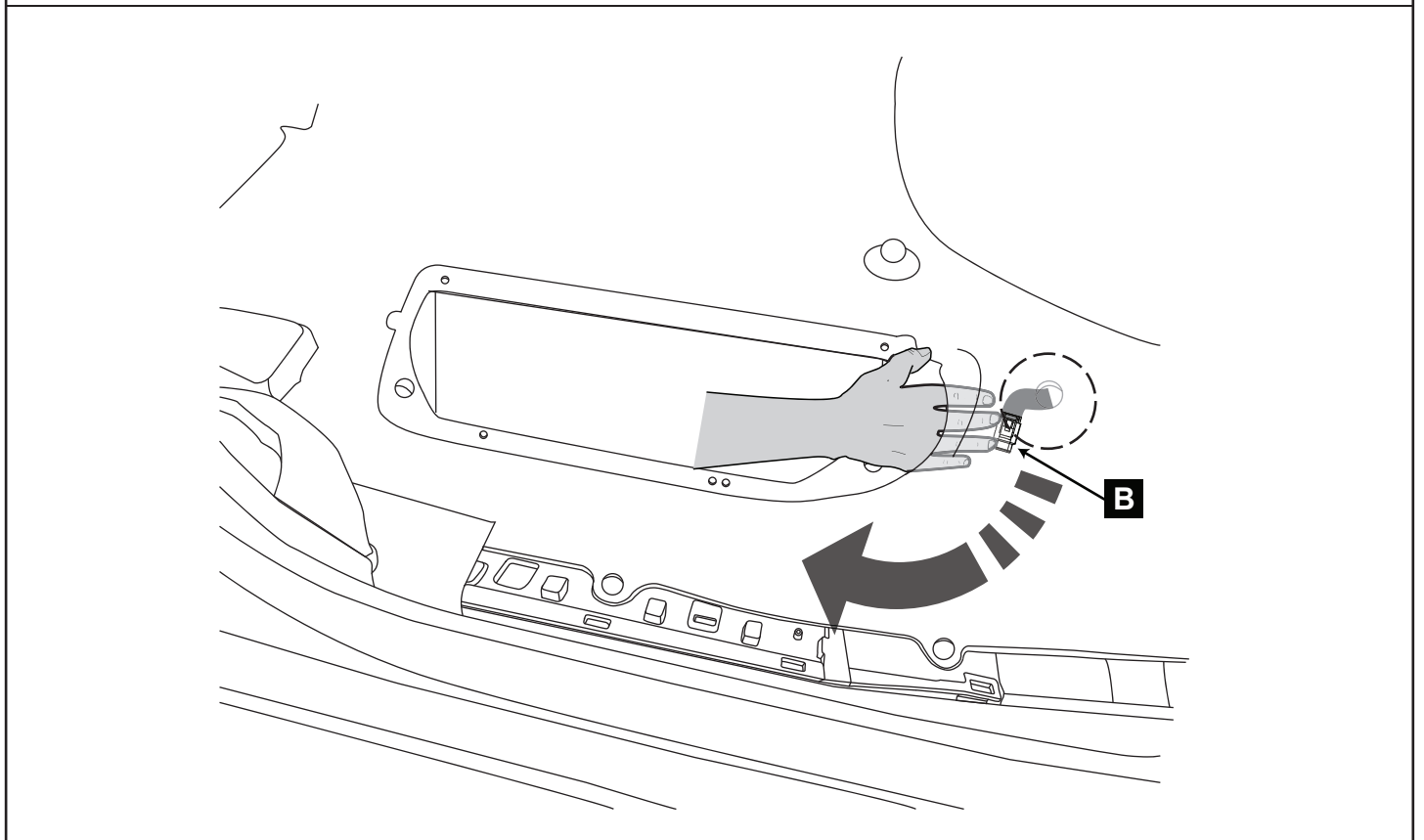

- 12** Feed Connector B, located at the T Junction, through the floor hole and pull through.



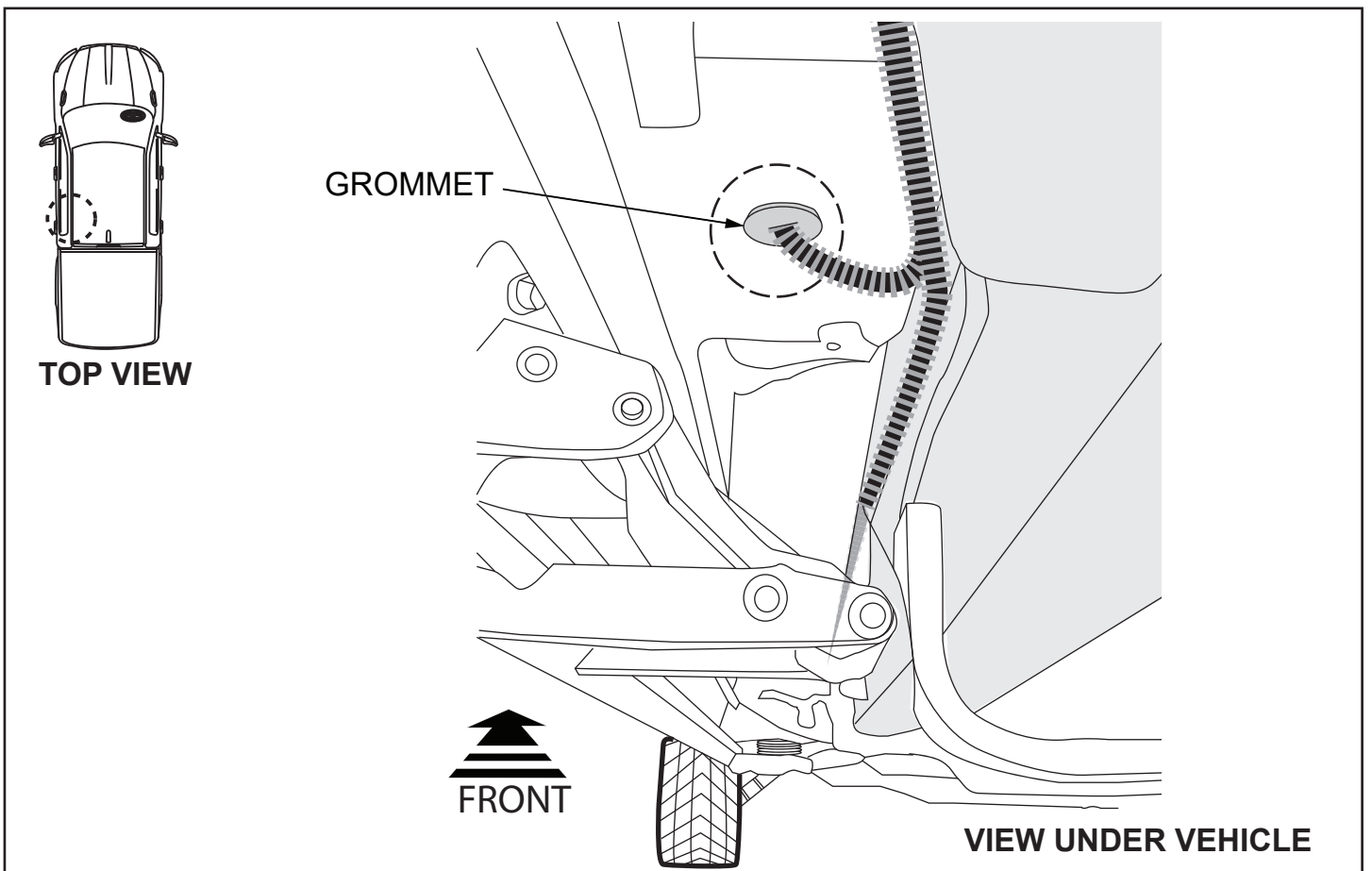

- 13** Run the wire between the carpet and the chassis. Pull the wire under the lower B-pillar trim panel. Ensure the cable does not interfere or touch seatbelt mechanism. Pull wire until grommet is pulled into the hole and seals tight.

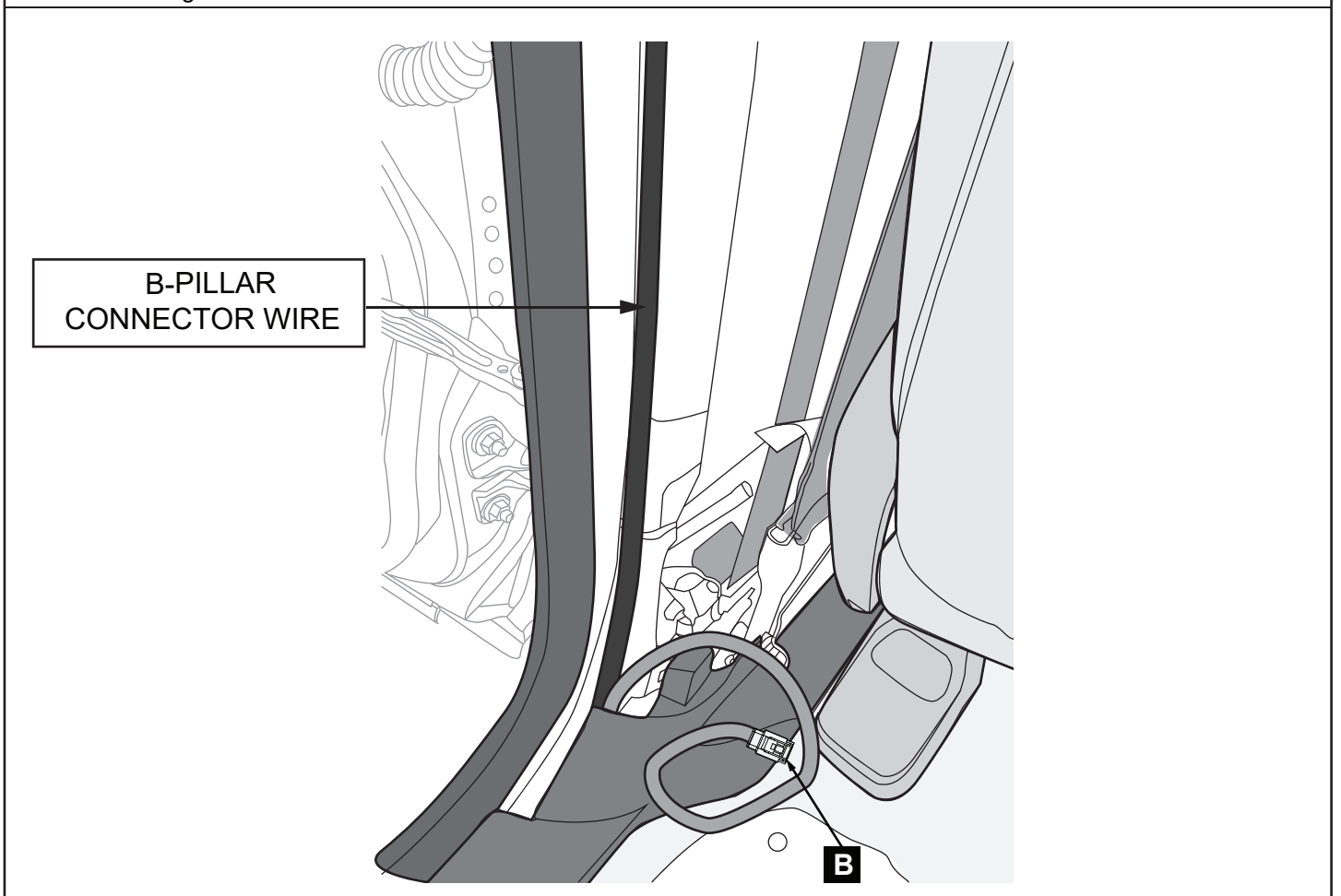

- 14** Bring Connector B up through lower B-pillar trim panel along side B-pillar connector wire and coil to the side. Ensure placement does not put cable at risk of being damaged.

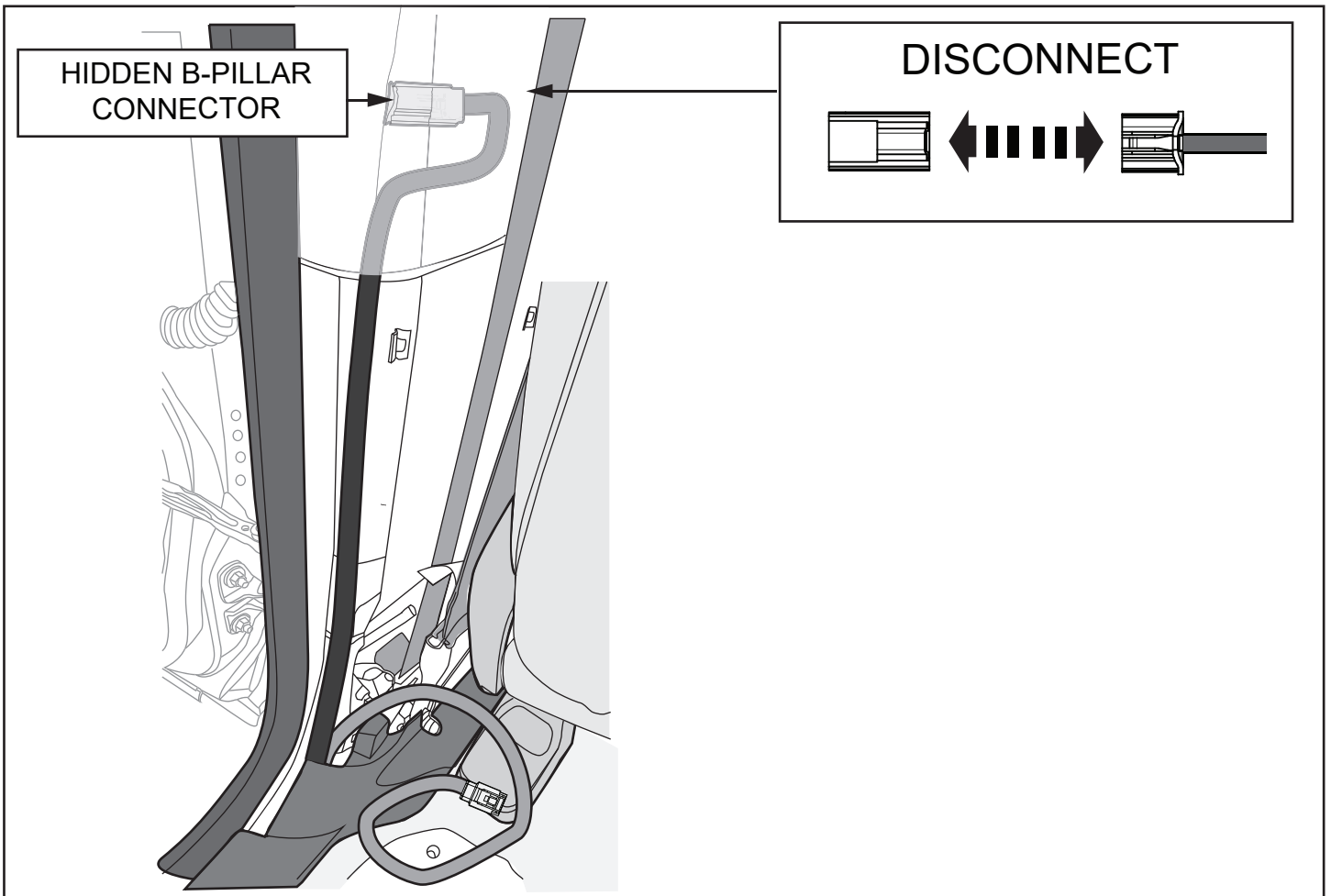

**15** Unplug the vehicle harness inside the B-pillar (top part hidden behind panel).

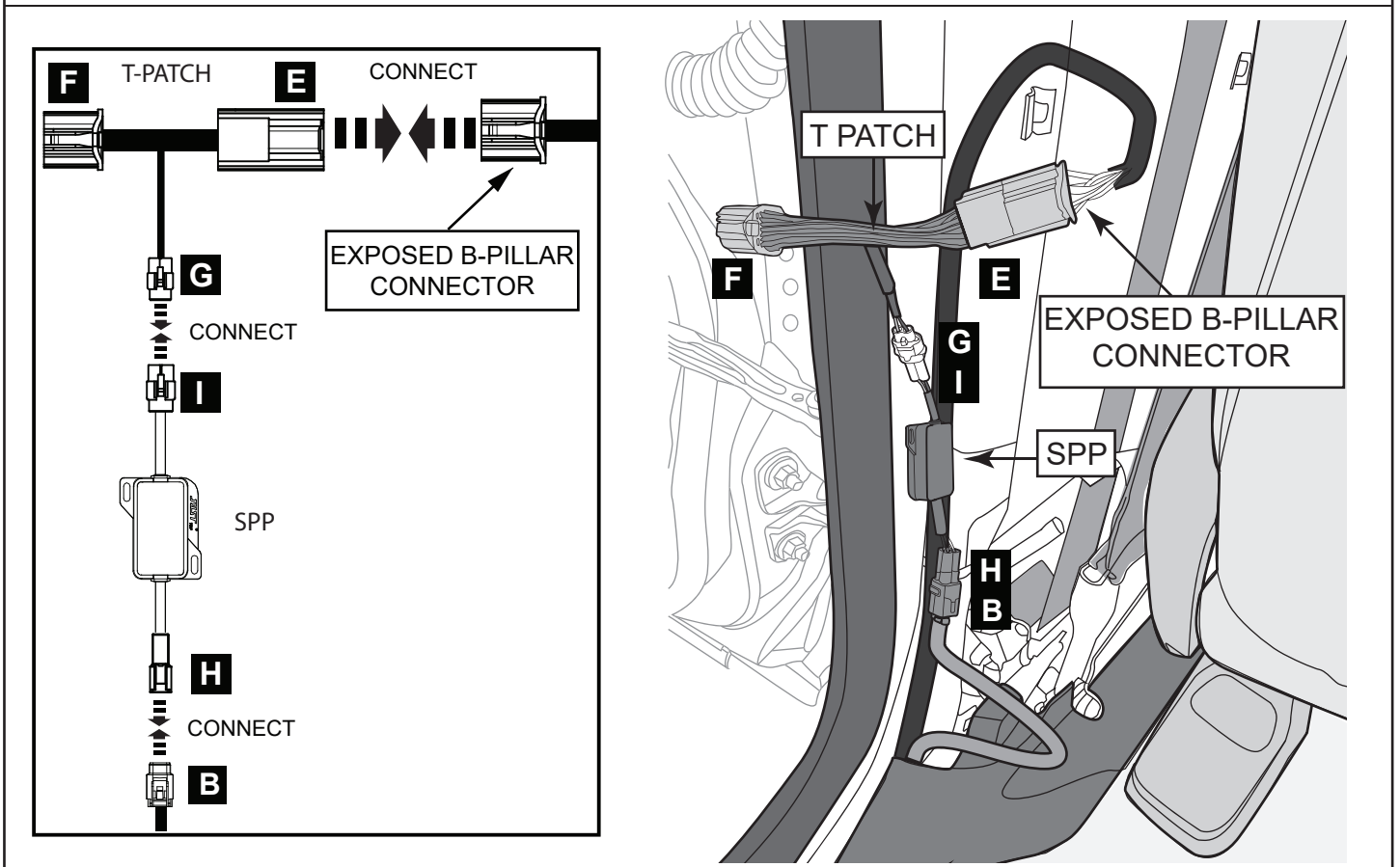

**16** Connect T-Patch and the SPP unit as shown.

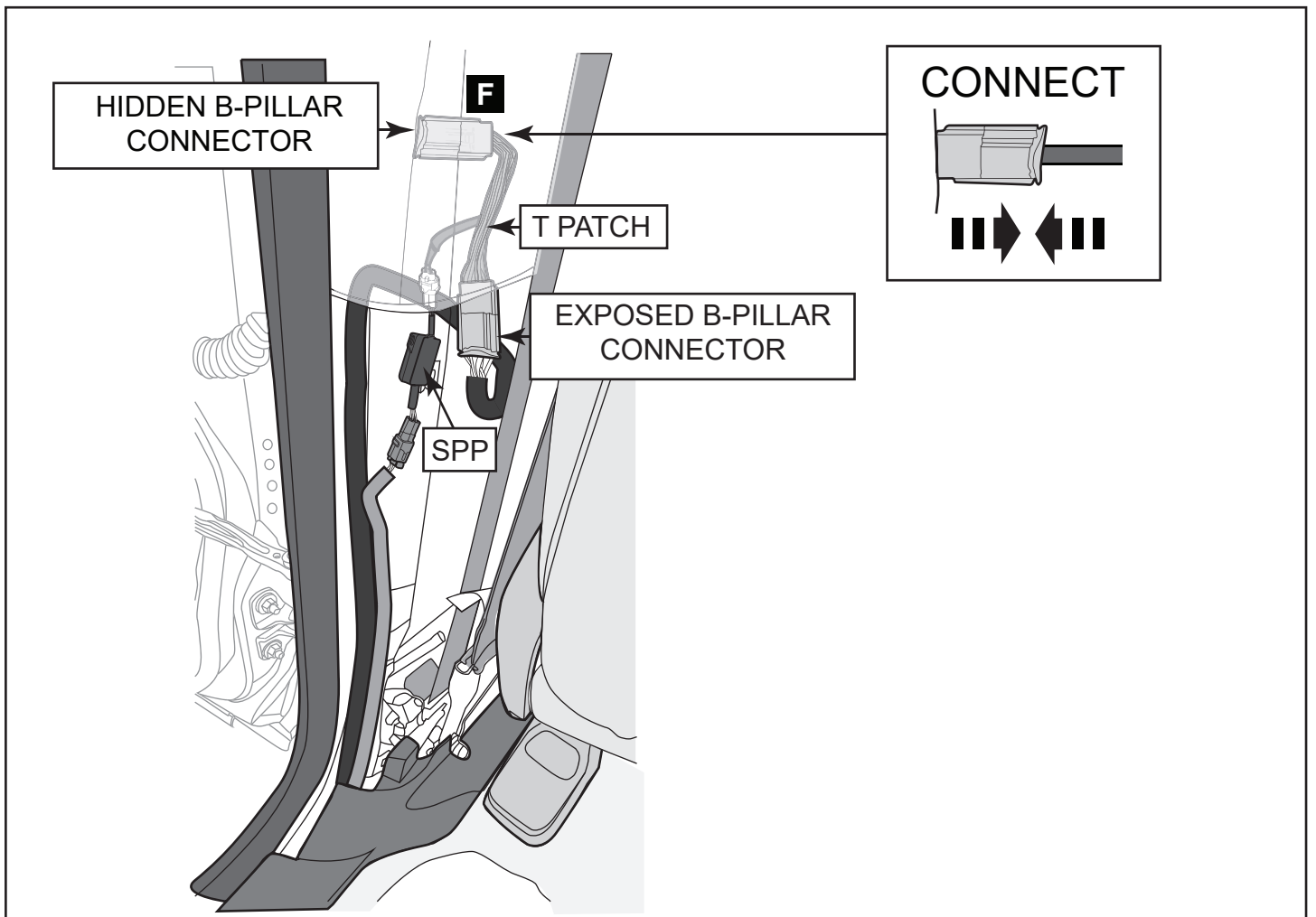

- 17** Connect T Patch to Hidden B-pillar connector. Ensure cables are secured safely away from the seat belt mechanism. Ensure cables are securely fastened to pre-existing wiring and secure points.

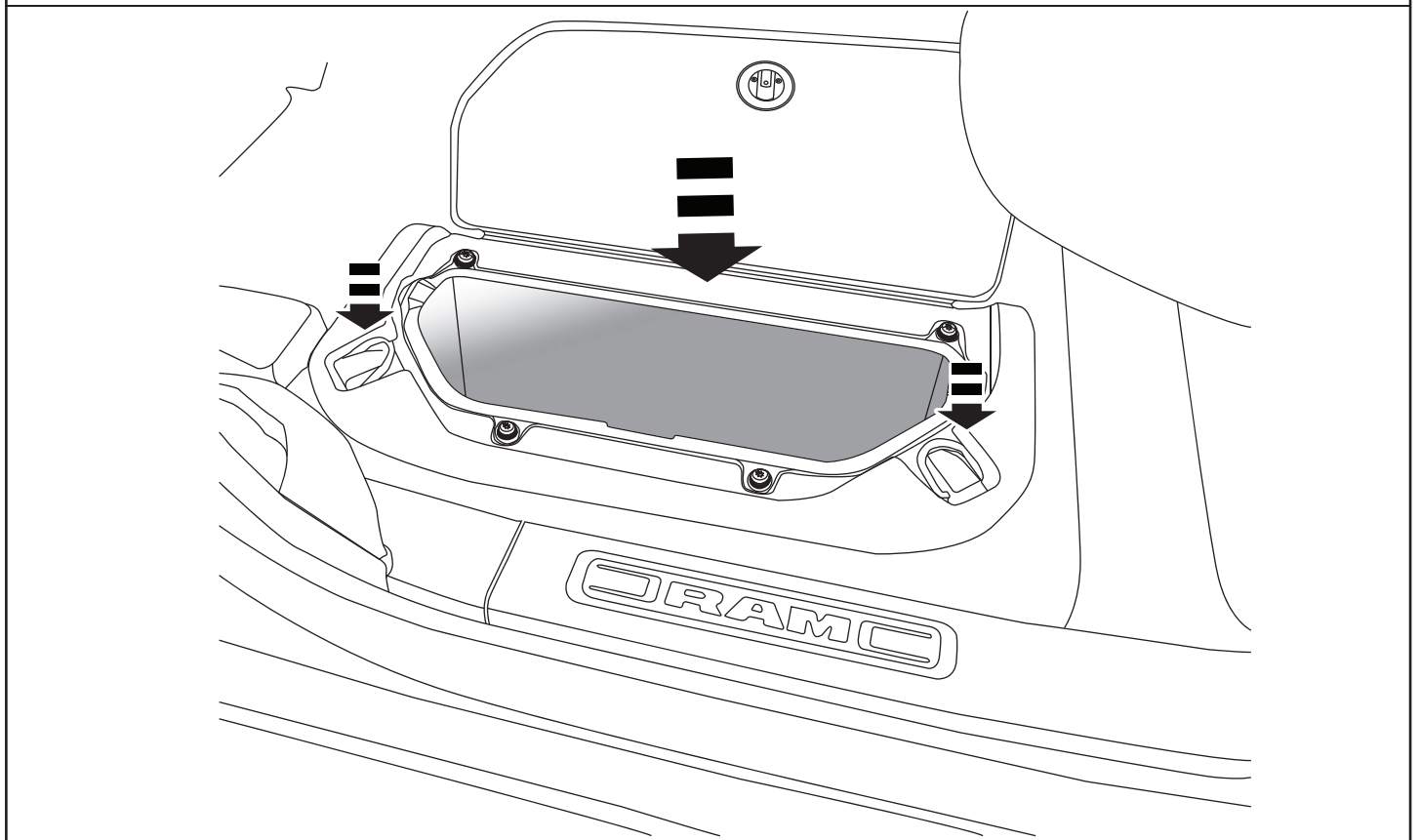

- 18** Re-fit carpet connectors. Re-fit scuff plate and upper B-pillar trim panel. Re-fit floor box assembly.



KEEP HANDS AND APPENDAGES CLEAR OF THE STEP AT ALL TIMES

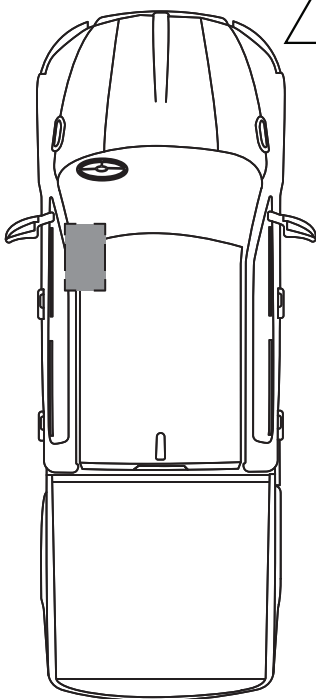

TOP VIEW

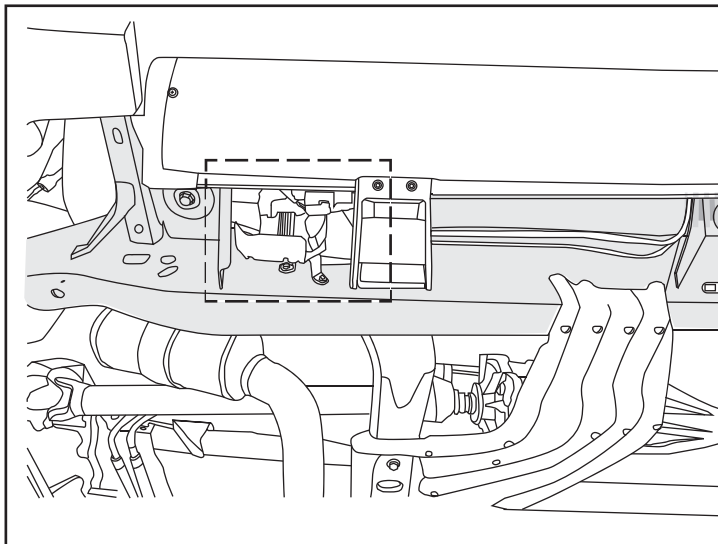

CONNECT

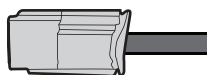

- 19** Close all doors. Ensure to wait 10 seconds before going under the vehicle. Keep hands and appendages clear of the step at ALL times. Failure to comply may result in serious injury. Plug previously disconnected step motor connector.

CONTINUE ON THE NEXT PAGE



DURING ASSEMBLY PROCEDURE SUPPORT AT CENTRE OF CANISTER ONLY, PLACE ON TOP AND BASE CARTON (OR SIMILAR), COVER WITH FOAM BLANKET. TO AVOID SCRATCHING POWDERCOATED SURFACES. DO NOT LOAD ELECTRICAL CONNECTORS OR MOTOR COVER.

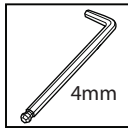
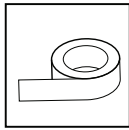

**FIT RHS FIRST**

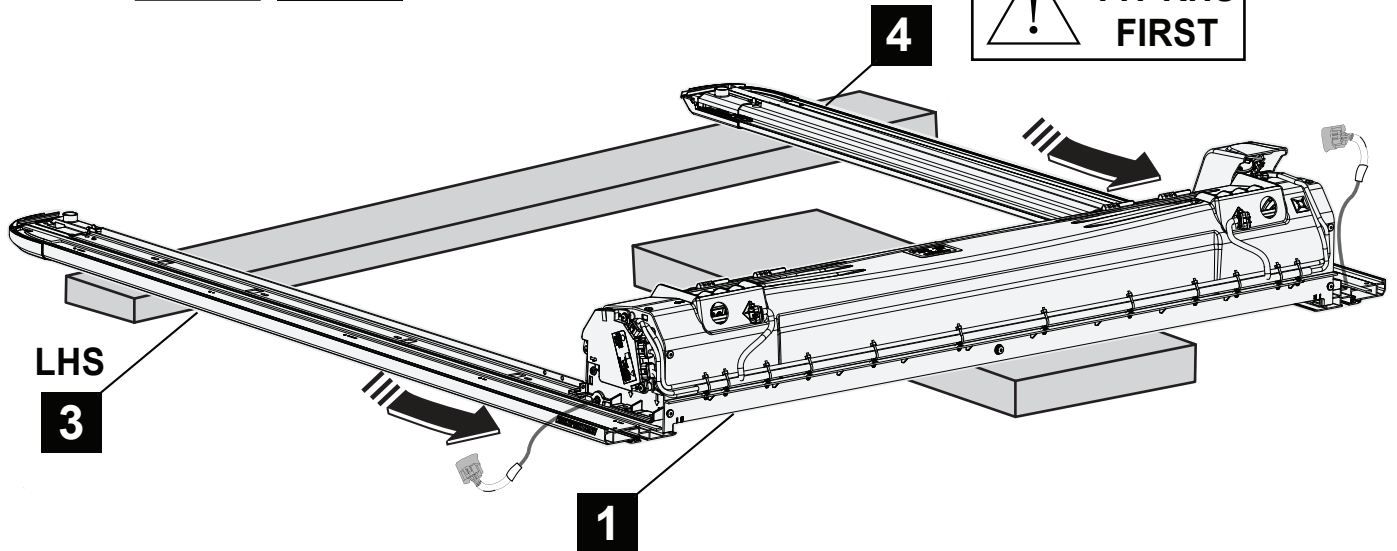

**1** **ATTENTION: SEAL MUST FACE IN THE DIRECTION AS SHOWN. WARRANTY VOID IF ASSEMBLED INCORRECTLY.**

HOLD SEAL FLAT USE CLOTH TAPE

**RHS SHOWN**

**APPROX 300mm**

**2** **ATTENTION: EXPOSE 3 SLATS PRIOR TO FITTING SIDE RAILS.**

ENSURE ENDS ARE ALIGNED

**ATTENTION: WIPE THE SEAL AND SIDE RAIL WITH WAX & GREASE REMOVAL TO ENSURE THE CLOTH TAPE WILL ADHERE TO THE SIDE RAIL AND SEAL**

**1** Place the canister (1) on two protected boxes as shown, ensure hand rail and slat ends are aligned. Tape up the seal on the Side Rail (3) as shown.  
**IMPORTANT:** Carefully align and slide the rail over the handrail contact and canister endplate taking particular care to ensure that the siderails are slid straight and no undue force is applied to the electrical contact. Details in following steps.

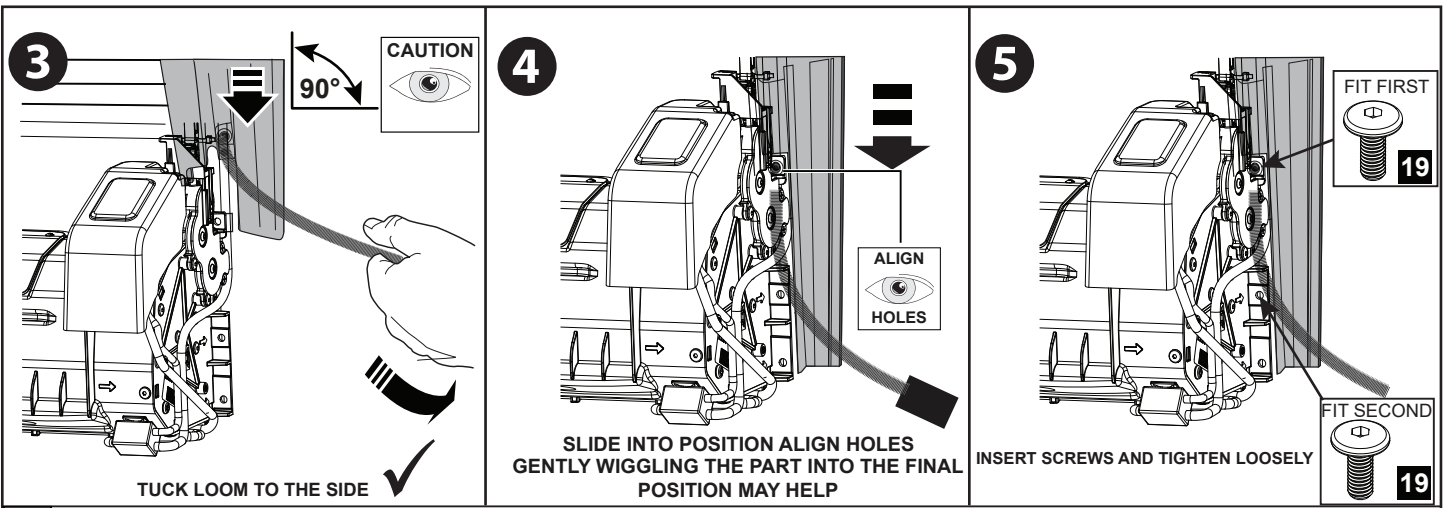

**2** Pull hand rail to expose 3 slats. Slide the RHS Rail over slat ends and onto endcap location pins. Align the holes and secure loosely with two screws (19). Do not tighten. Repeat for LHS Rail (4)

DURING ASSEMBLY PROCEDURE SUPPORT AT CENTRE OF CANISTER ONLY, PLACE ON TOP AND BASE CARTON (OR SIMILAR), COVER WITH FOAM BLANKET. TO AVOID SCRATCHING POWDERCOATED SURFACES.

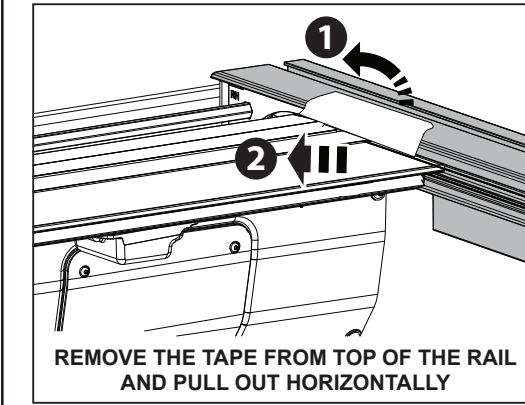
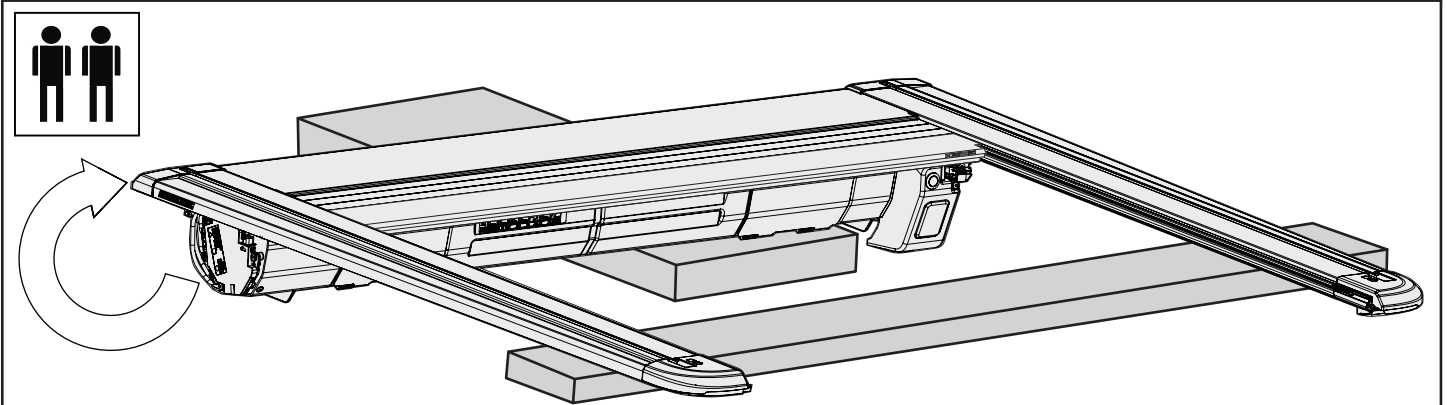

**CAUTION**

ALIGN CAREFULLY

**ATTENTION: SEAL MUST FACE IN THE DIRECTION AS SHOWN. WARRANTY VOID IF ASSEMBLED INCORRECTLY.**

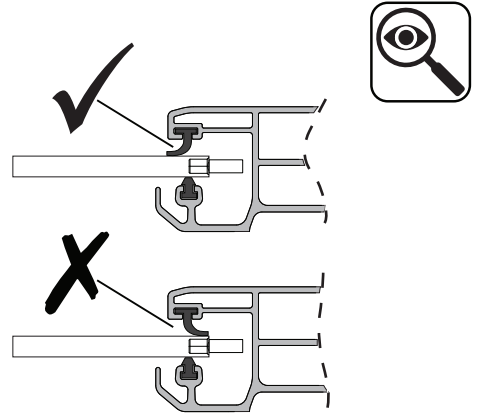
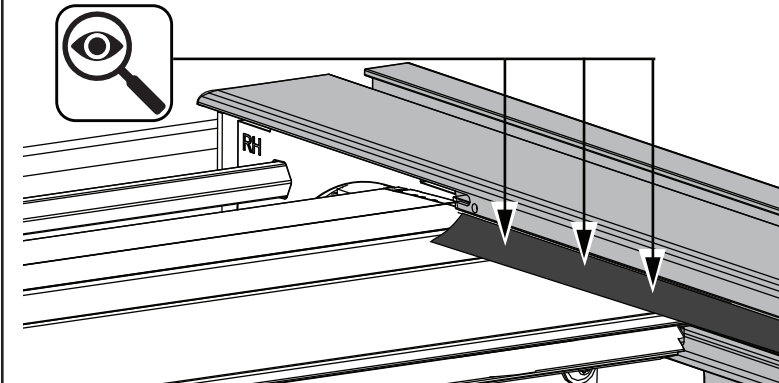

CHECK SEAL IS IN POSITION AND NOT DAMAGED

**3** Carefully lay the assembly over onto a protected surface. Remove the tape holding the rubber seal and check the seal position as shown. Repeat for LHS Rail.



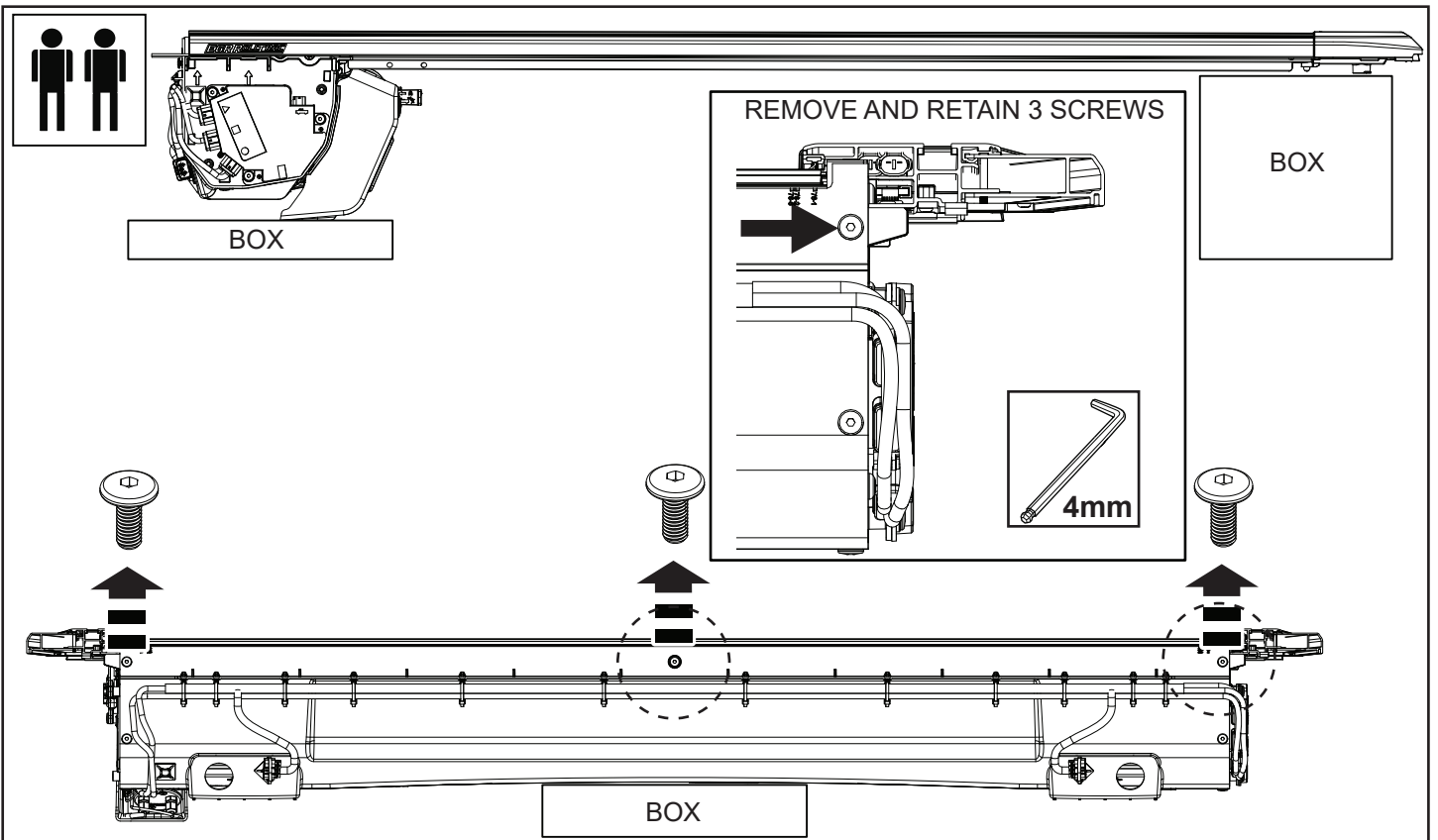

- 4** Remove the 3 pre-fitted screws from the rear of the cover which will be used to secure the Front Cover (2) to the assembly. Ensure the product is not scratched or damaged when laying flat.  
**IMPORTANT:** Do not apply load to the electrical connectors and do not sit product on motor cover.

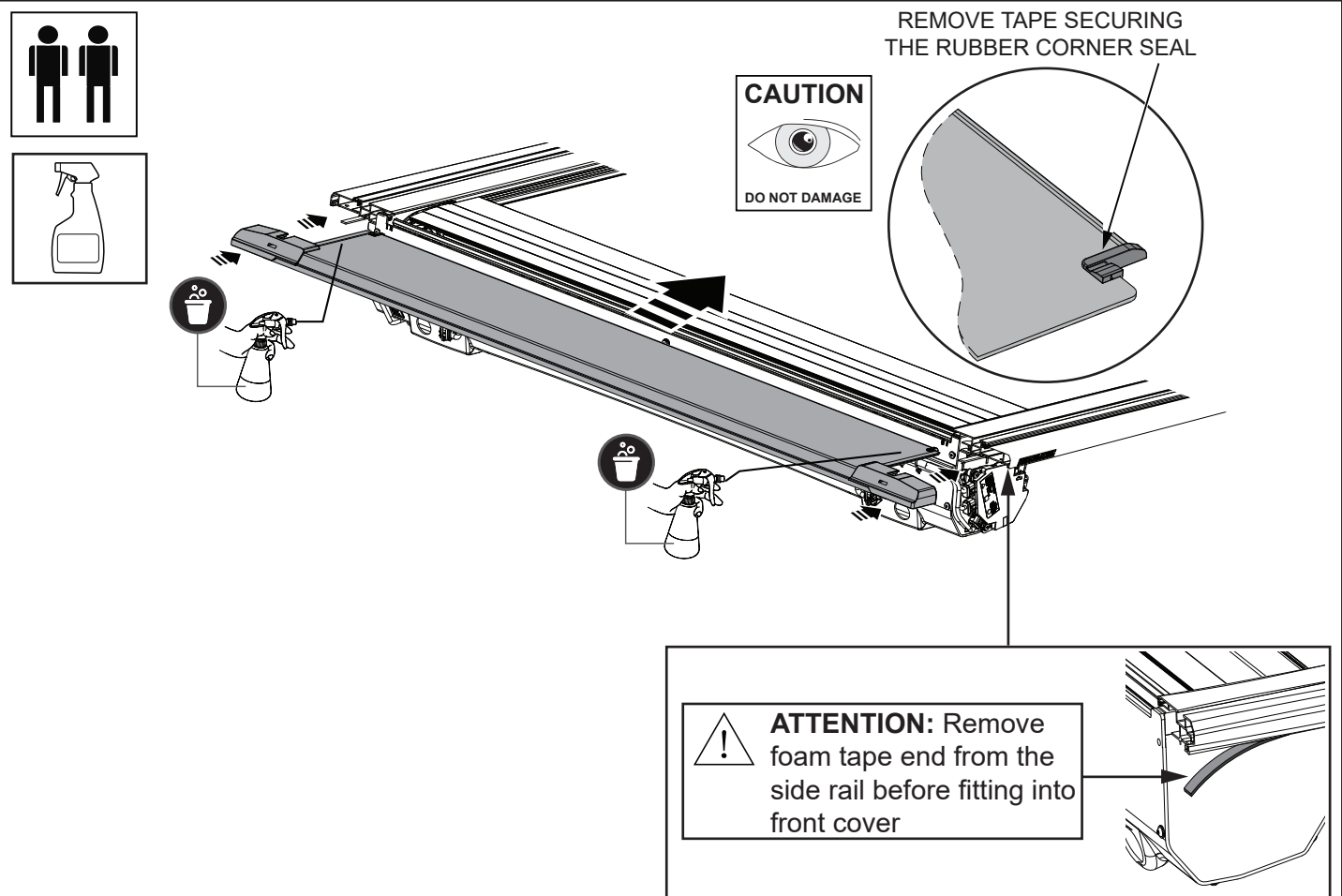

- 5** Slide the Front Plate (2) over the canister and into the side rail channels ensuring that the foam side rail tape is pulled out of side rail and the small rubber corner seal on the RHS and LHS of the front plate are not damaged.  
**IMPORTANT:** Spray the front cover edge with soapy water to allow it to slide easily into the sides, twisting side rails outwards will also help.



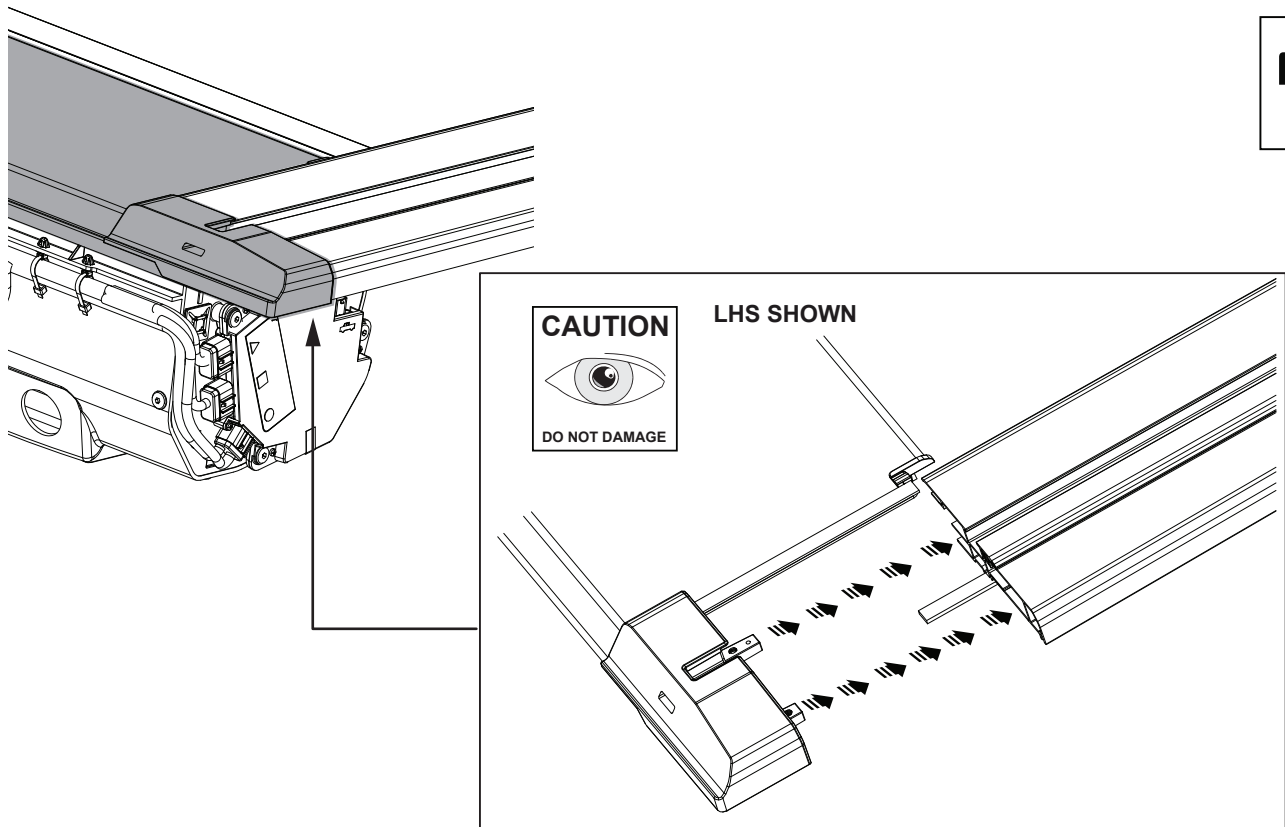

**6** While sliding the front cover ensure the cast connectors are align.

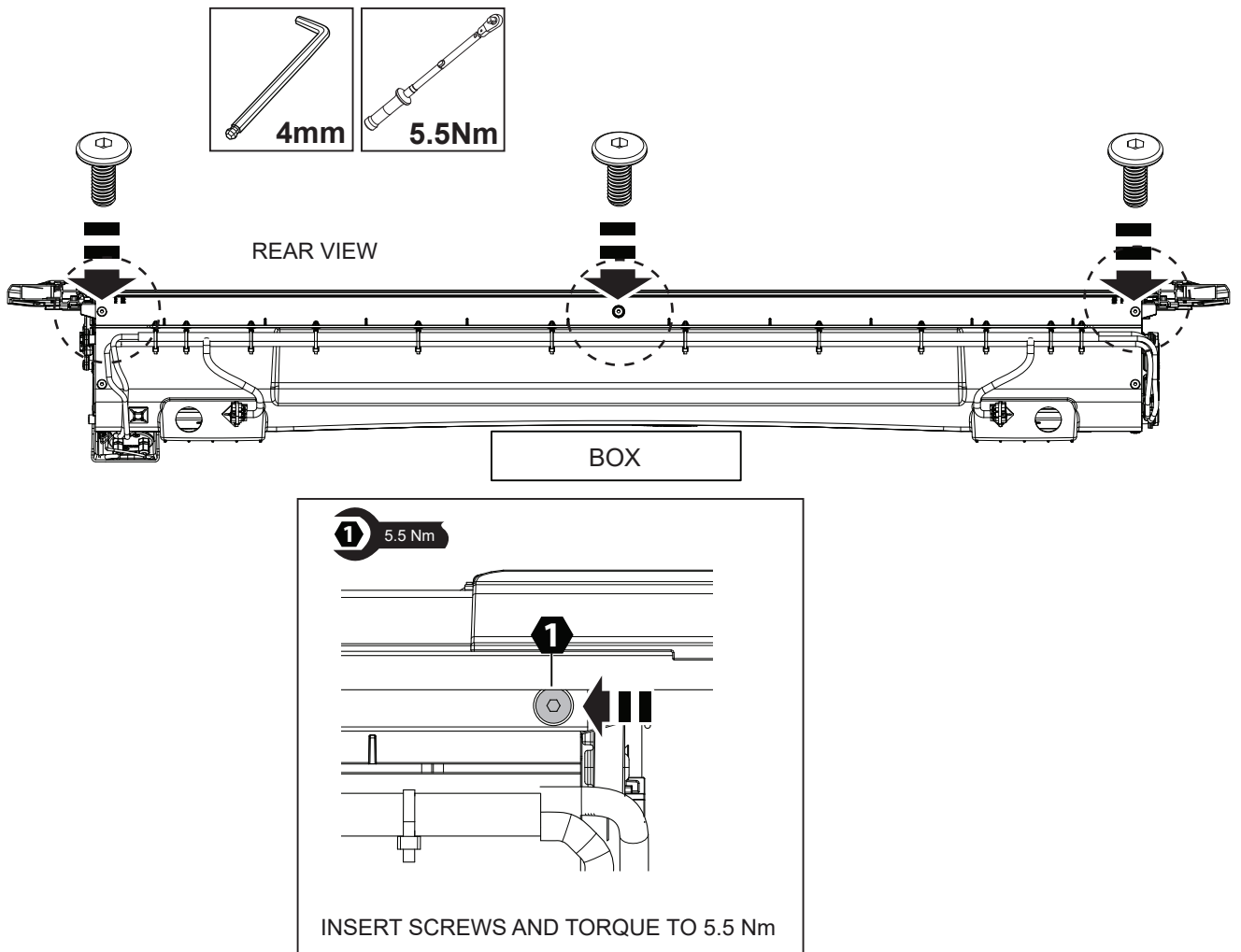

**7** Using the 3 screws removed from Step 4, secure the Front Plate (2) to the Canister Assembly (1) and torque to 5.5 Nm.

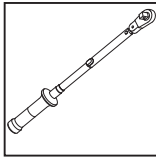
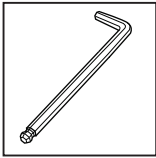

SIDE VIEW



LHS

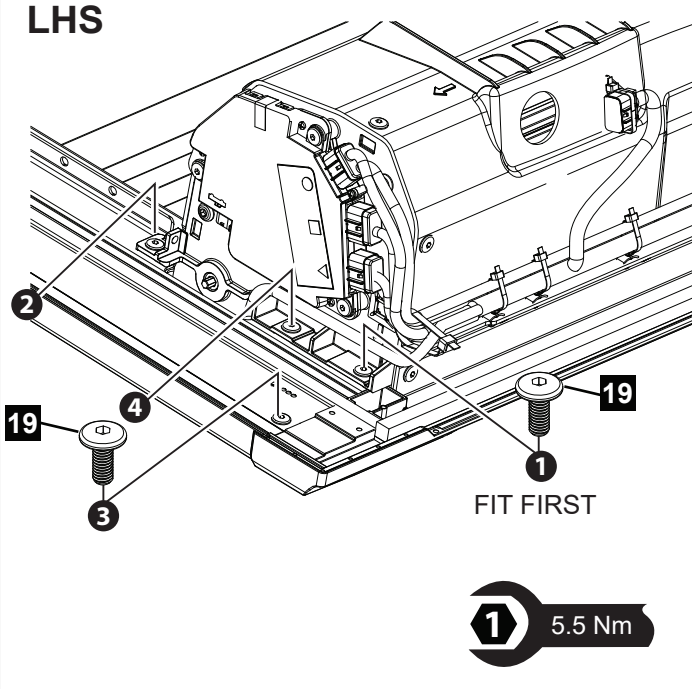

RHS

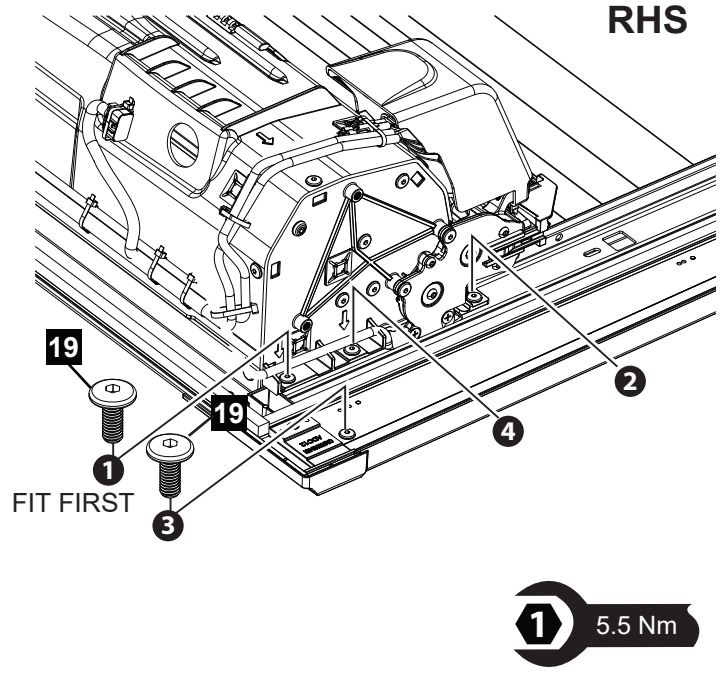

- 8** Carefully flip the assembly over onto a flat protected surface which will not damage the cover or scratch the paint work. Install the 2 screws (19) on each side through the canister and side rail into front cover. Torque all screws in order shown to 5.5 Nm.

LHS SHOWN - RHS IS A MIRROR IMAGE

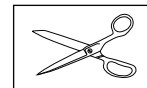
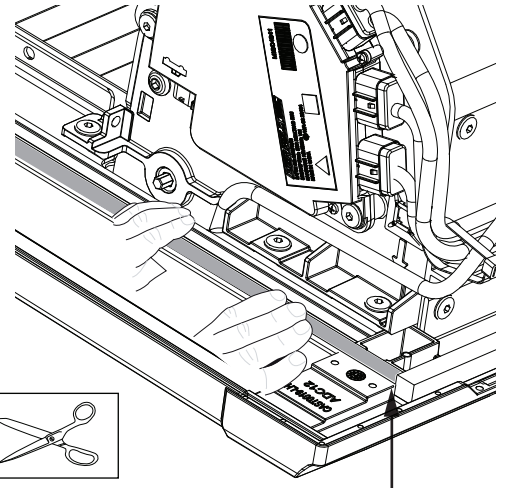
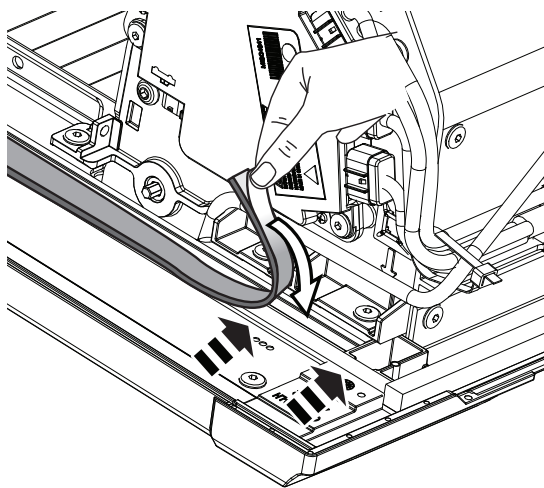

CLEAN WITH ALCOHOL FIRST

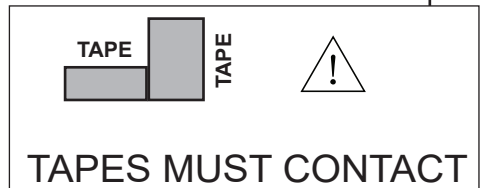

- 9** Clean powder coated surface first with alcohol spray. Trim foam tape length to ensure the end will butt against front cover seal - avoiding any gap. Peel the protective liner from the foam tape, adhere to the channel in the side rail, Press down firmly to secure. Repeat on RH side rail.

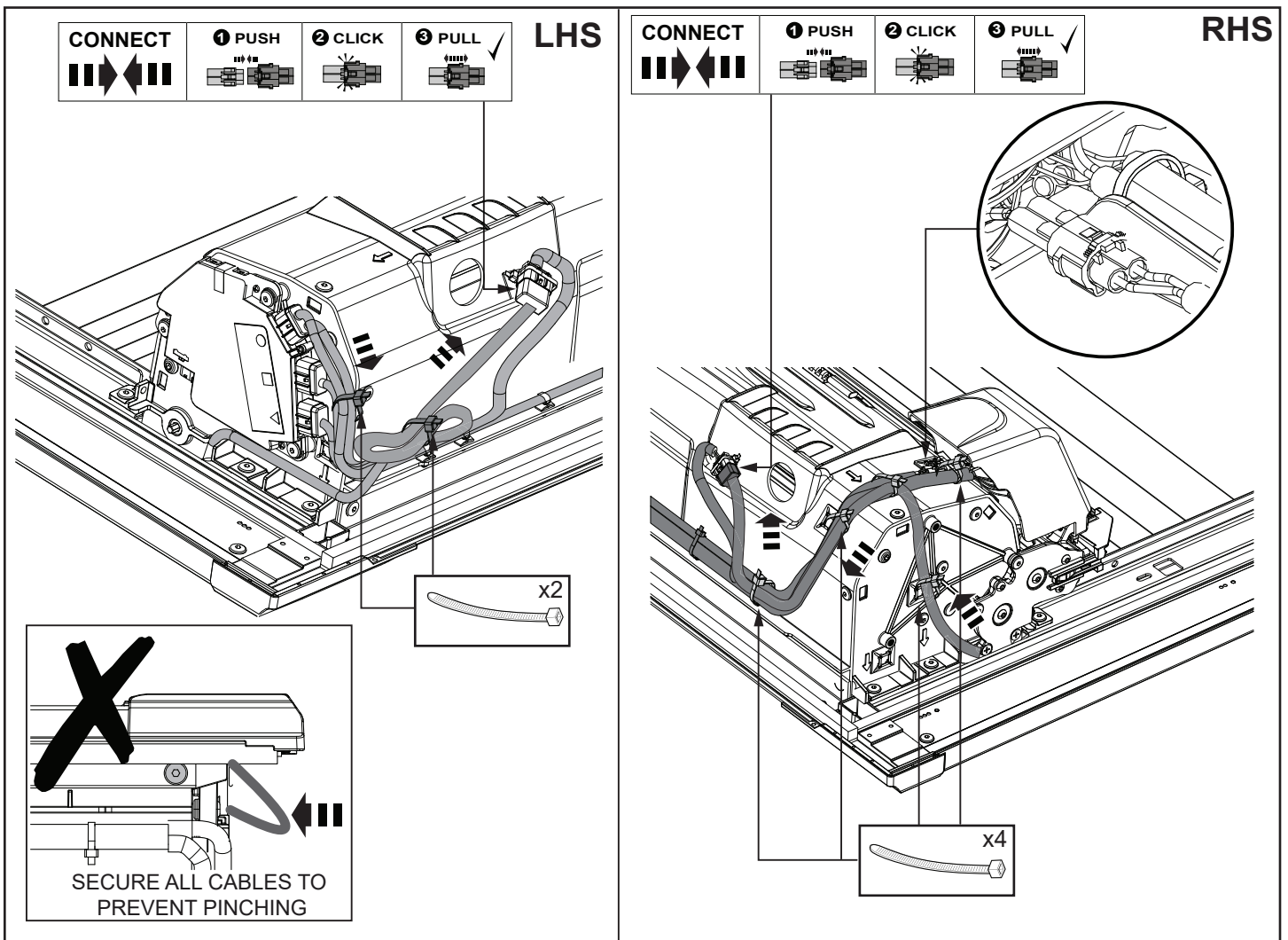

- 10** Connect side rail harness connectors to the connectors on the canister on the LHS and RHS. Connect the lamp connector as shown next to the motor on the RHS. Secure the harness to the canister using cable ties and pads as shown. Ensure all cables are retained to prevent pinching during installation.

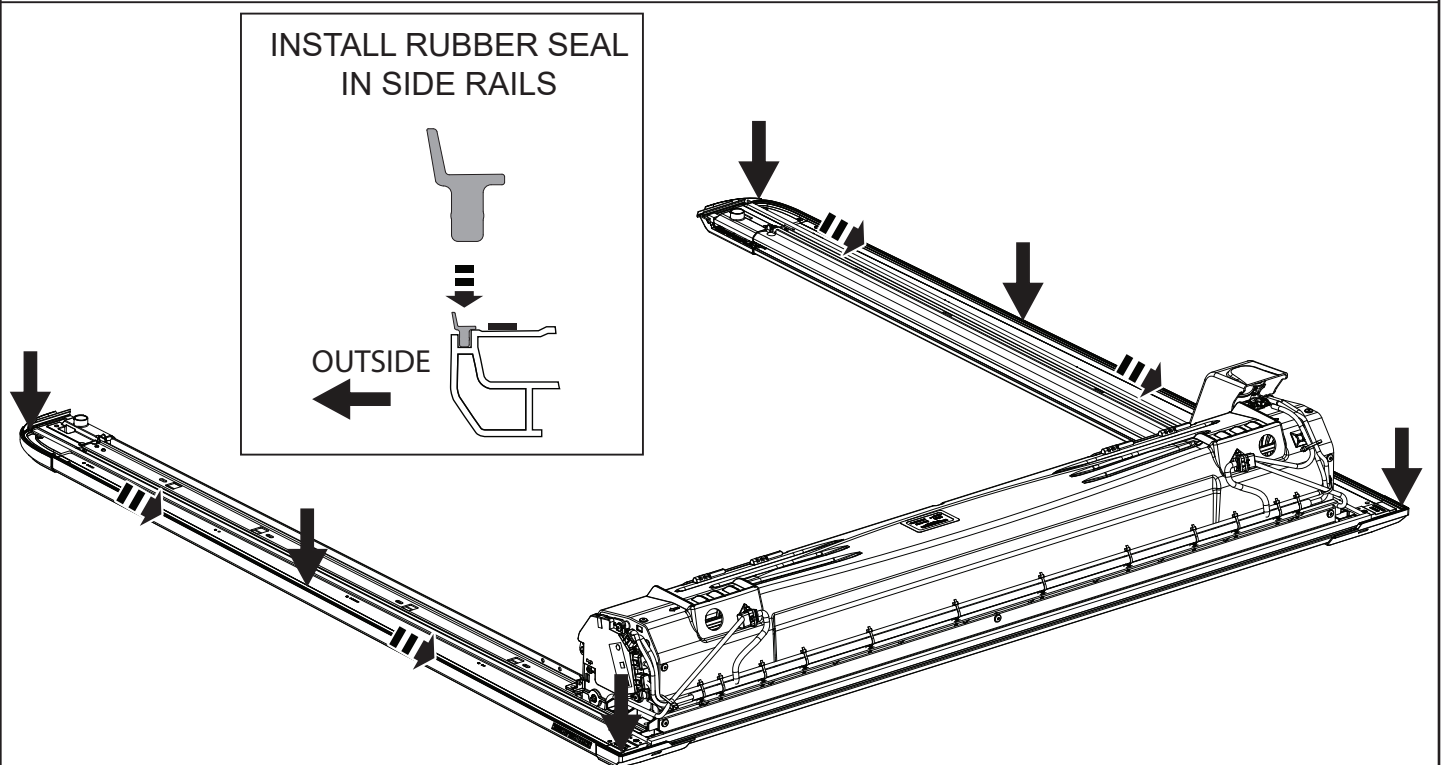

- 11** Install the Rubber Perimeter Seal (26) into each side rail and ensure seal is firmly seated (note the seal orientation). **Important:** do not stretch the seal while fitting.

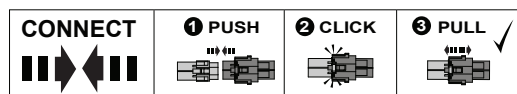
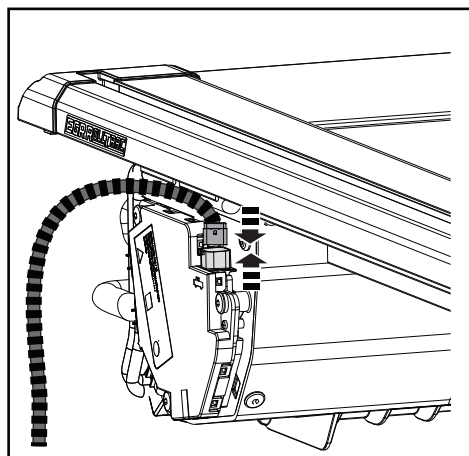
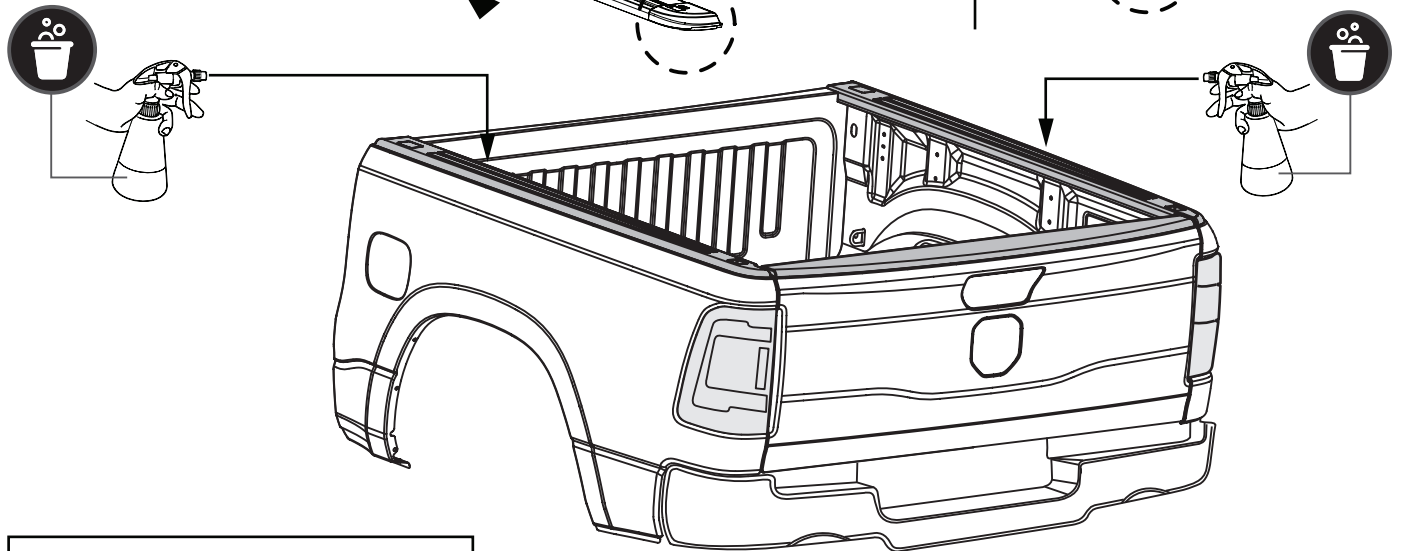
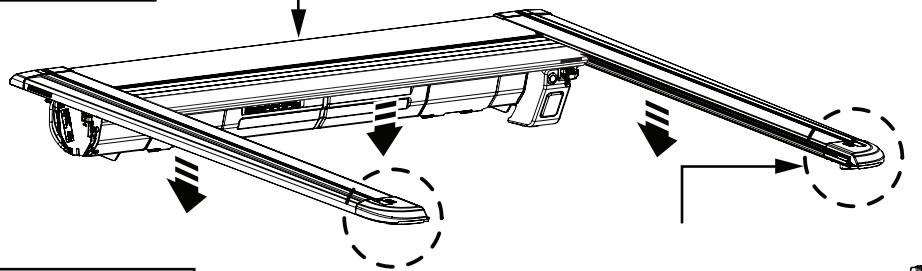
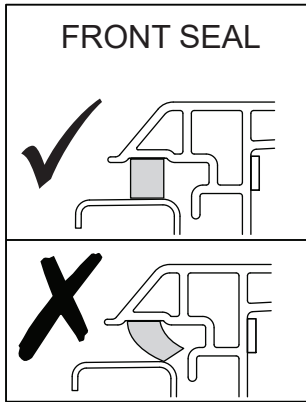

PULL THE CONNECTORS  
NOT THE CABLE

- 1 Spray the top surface of the vehicle bed liberally with a soapy water solution to enable the Cover to slide easily. Using two people to lift the cover from both sides and carefully lower it onto the bed. Connect the vehicle harness to the ECU as shown. **NOTE:** You may have to lift the LHS of the cover and use packer to aid connection. Ensure all seals are sitting vertically as illustrated, by lifting the cover and dropping vertically into position.

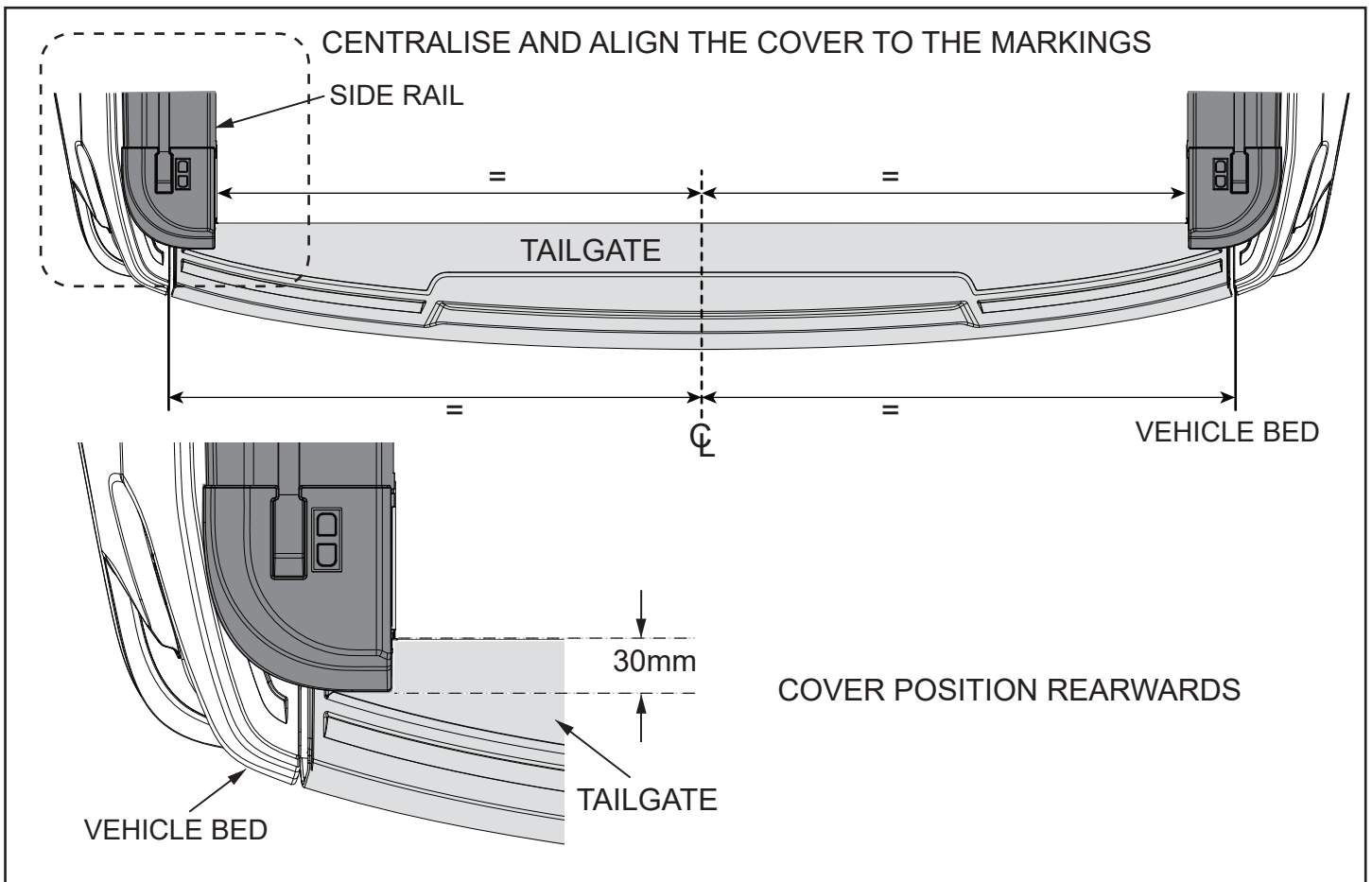

- 2** Adjust the front/back position of the cover so that it is 30mm rearward of the tailgate inner edge as shown. Apply masking tape at the centre of the tailgate. Measure the distance between the rear corners of the vehicle bed and draw a centre line on the masking tape. Measure the distance from the marked centre line to both rear corners of the RollTrac and ensure the side rails are parallel and equally distanced. Ensure seals are not deformed when repositioning cover.

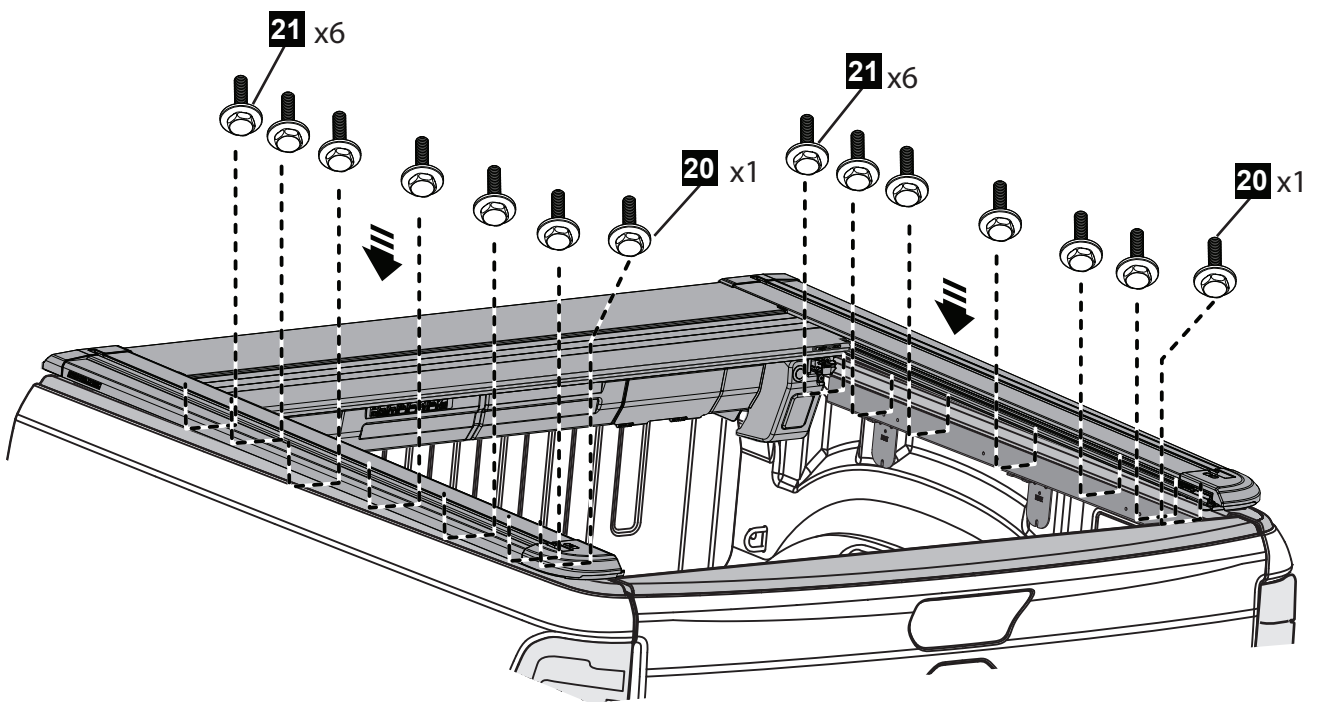

- 3** Assemble the Rolltrac side rail to the mount extrusion with screws on each side as shown, tighten loosely.



# PERFORM FITMENT CHECK



A = A    B = B

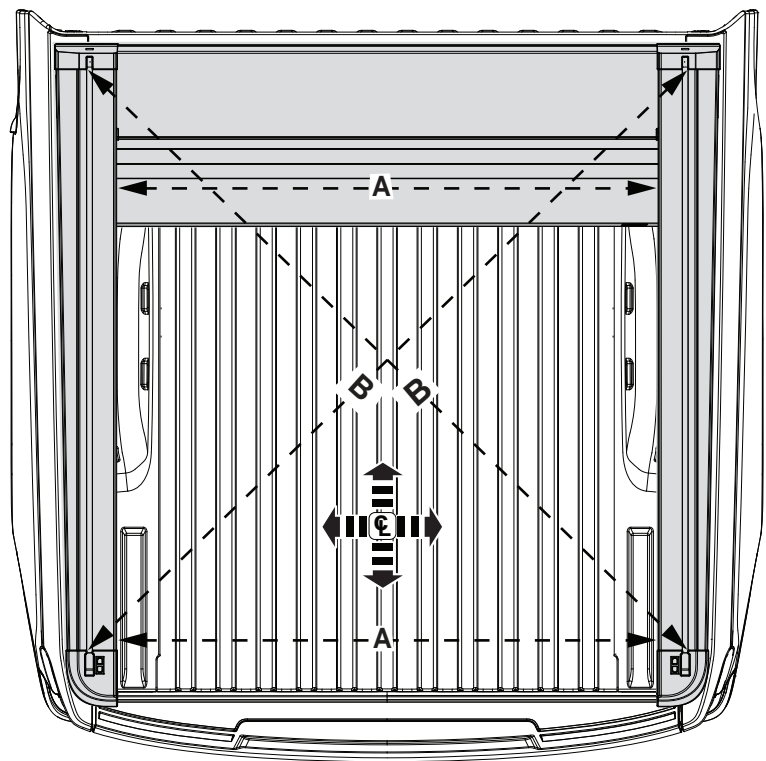

**4** Perform width check (using canister end as reference) and diagonal fitment check (mounting bolts may need loosening for adjustment). Open and close the cover by hand, checking for smooth operation and consistent 1.5-2.0mm side to side free-play of slat assembly within side rails. If there are any tight spots, then check side rail position and re-adjust side rail width as required.

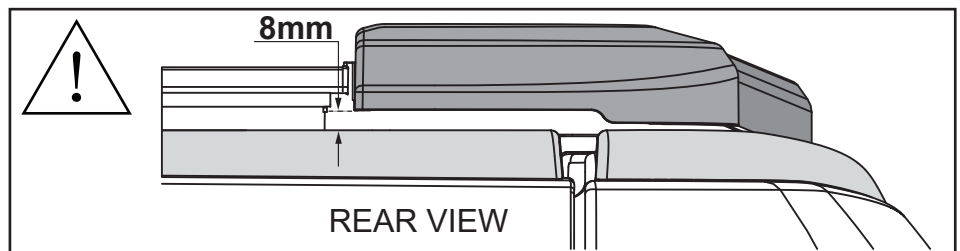

VIEW UNDER THE SIDE RAIL RHS (TUB NOT SHOWN FOR CLARITY)

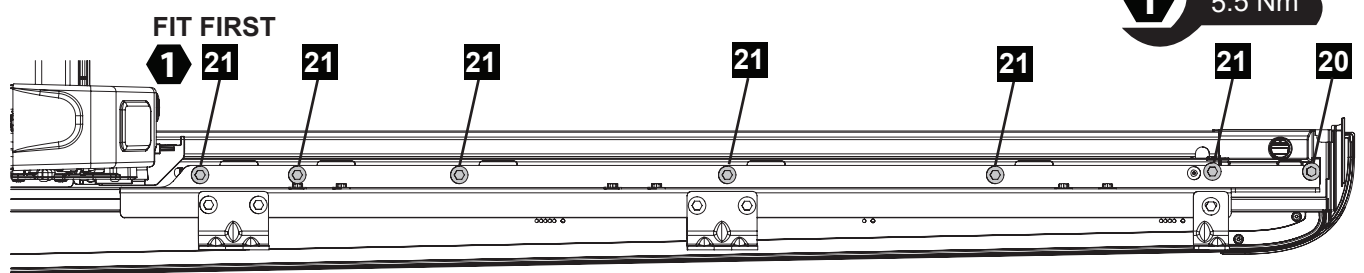

**5** Working from RHS to LHS (to avoid one side lifting up) torque all screws (21)&(20) to 5.5Nm. Perform final fitment check as per step 4. **IMPORTANT:** Check the clearance between rear corner casting and top of tailgate, target is 8mm. Open and close the tailgate to check function of seal (makes contact with tailgate and does not over compress) if position requires adjustment refer to steps 12-14 (section A).

CONNECT FRONT DRAIN TUBES TO CANISTER

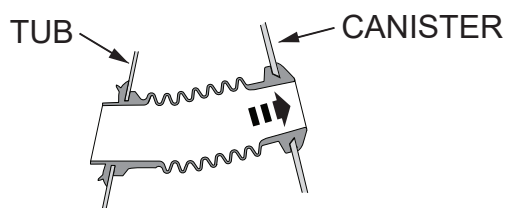

FIT REAR DRAIN TUBES TO SIDE RAILS

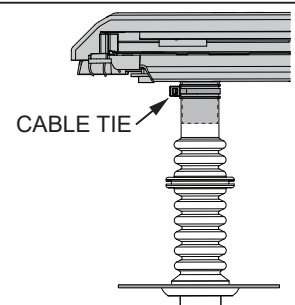

**6** Connect the front drain tubes to the canister. Connect the rear drain tubes to side rails and secure with cable ties.

# SILICONE LUBRICATION TO THE SPIRALS

(MODELS MAY VARY, IMAGES FOR REFERENCE ONLY)

**1** Open tailgate and EGR RollTrac

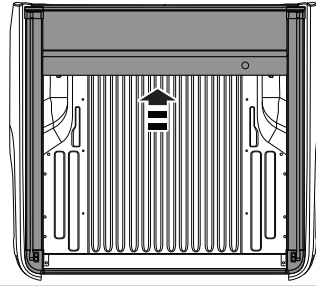
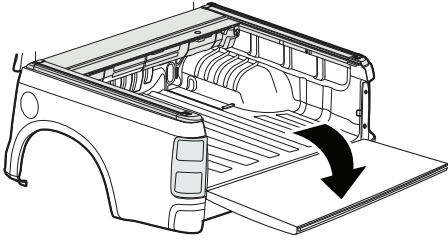

## TOOLS REQUIRED:



Allen Key 2.5mm



Silicone Spray

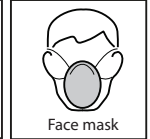

Face mask

**2** Using a 2.5mm Allen Key remove the 4 screws and open the inspection covers.  
**WARNING:** Keep clear of moving parts and avoid unnecessary operation of the EGR RollTrac while inspection covers are open.

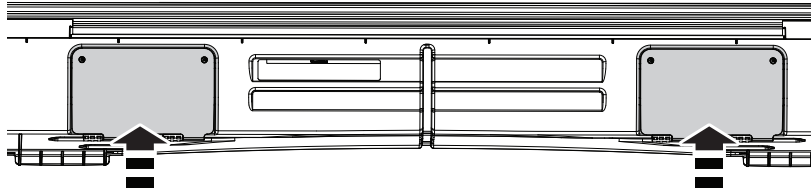

INSPECTION COVER

INSPECTION COVER



Allen Key 2.5mm

**3** Close the EGR RollTrac to access canister internals

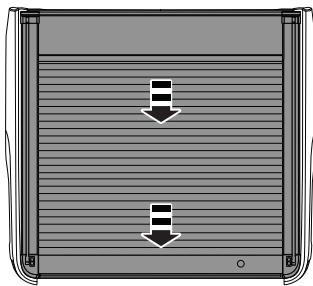

**4** To avoid water leaks, look into the inspection points and check that the flanges of both front drain tubes are correctly engaged to the canister cover (without any kinking etc.), readjust if required.

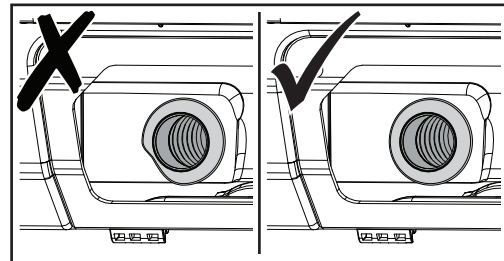

**5** Using plastic compatible 100% Silicone Spray (ONLY) spray onto the spirals on both ends of the canister through the inspection points.

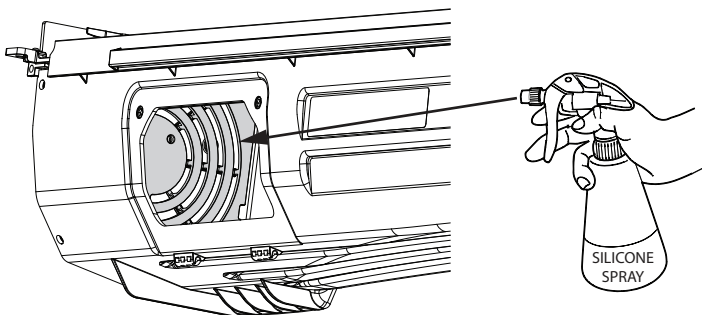

**6** Open the EGR RollTrac

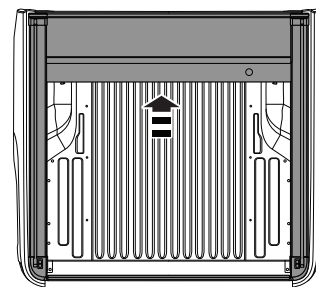

**7** Close the inspection covers and secure with retained screws. Open and close the EGR RollTrac to distribute lubricant and check operation.

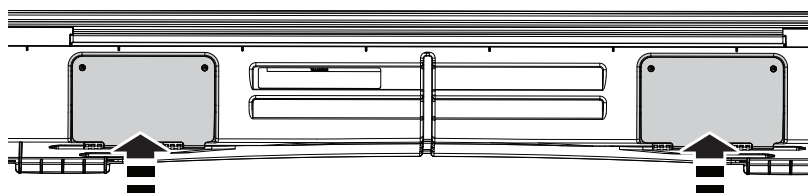

INSPECTION COVER

INSPECTION COVER



Allen Key 2.5mm



1. Insert fuse to EGR RollTrac harness.
2. Make sure the tailgate is open.
3. Engage motor, pull out lever (clutch).
4. Make sure the vehicle is unlocked and driver door open.
5. Press both buttons and hold for 10 sec. until light illuminates.



**WARNING:** Keep obstructions clear of cover during calibration mode.

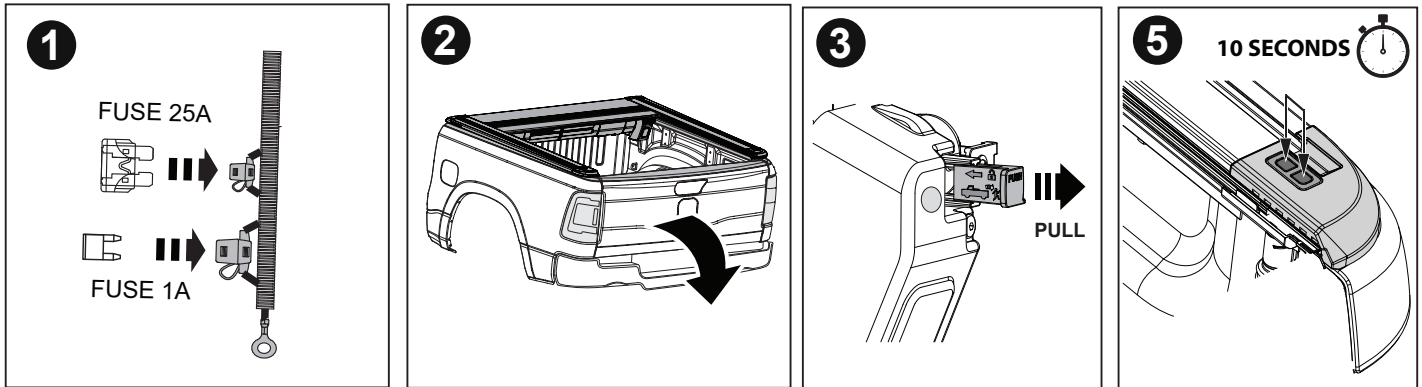

- Cover will open and close twice automatically.
- The EGR RollTrac internal LED light will pulse slowly during calibration and stop pulsing when calibration is complete.

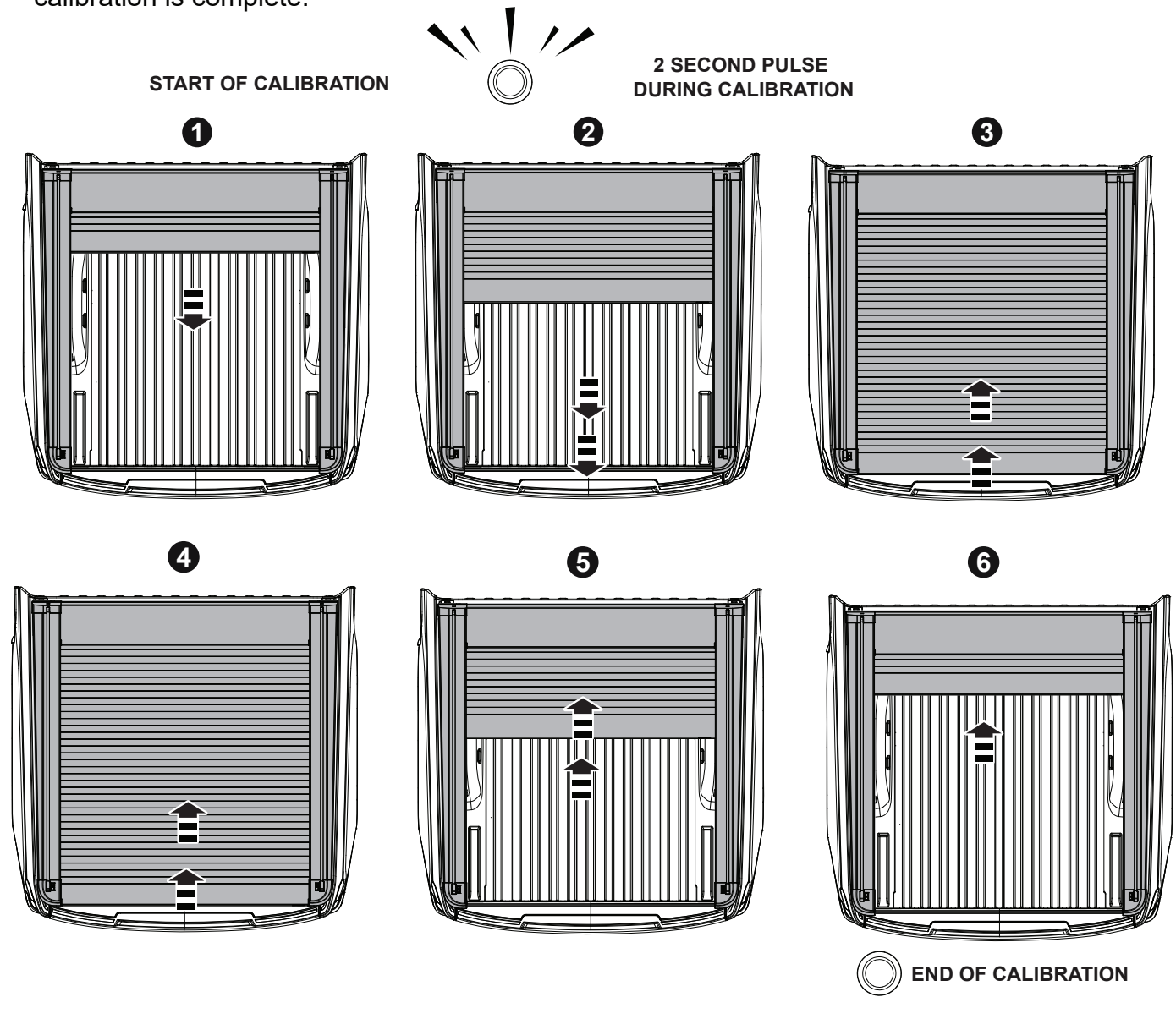

END OF CALIBRATION

# OPENING AND CLOSING PROCEDURE

## Electric Opening Procedure:

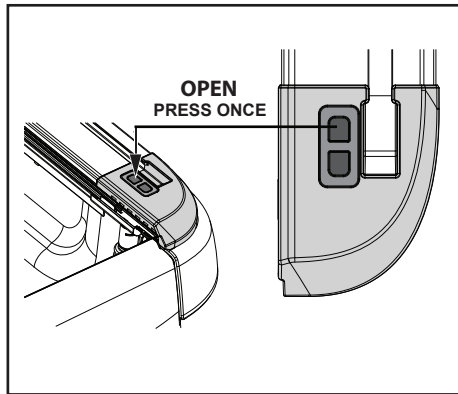
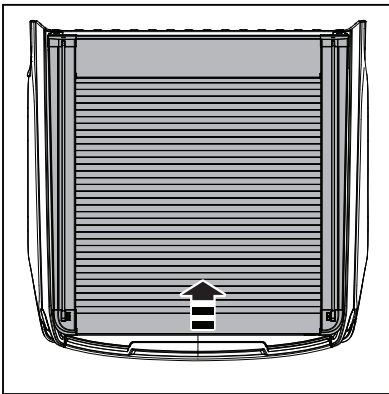

1. Press the front button on the EGR RollTrac side rail as shown.

## Electric Closing Procedure:

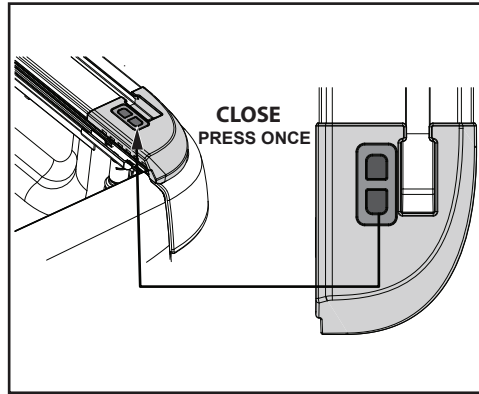
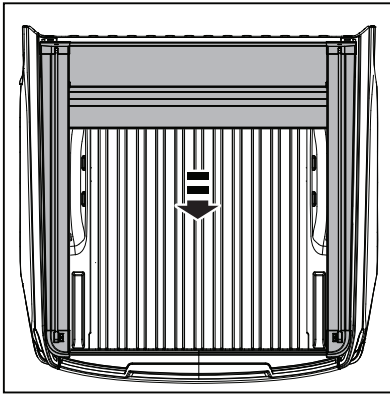

1. Press the rear button on the EGR RollTrac side rail as shown.

**NOTE:** EGR RollTrac should open and close smoothly. If cover does not lock or open correctly, please refer to the trouble shooting section in the Owners Manual. If the EGR RollTrac closing is slow, clean the siderails and ensure that no dirt or debris is inside the drive rail.

## Manual Opening and Closing Procedure:

Locate the Clutch Disengagement Lever on the RH side of the cover and push the Clutch inward to disengage the motor. Pull the cover rearward or forward as required. Before driving vehicle ensure you re-engage the clutch.

**IMPORTANT:** If clutch was disengaged, calibration procedure needs to be re-run prior to electric operation.

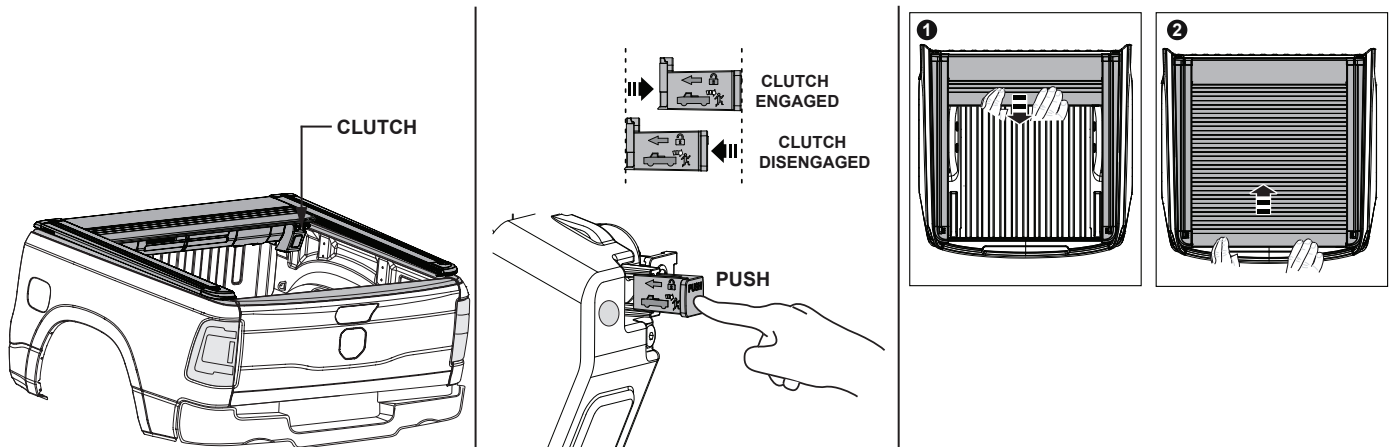

## RIVETING SIDE BRACKETS

ROLLTRAC NOT SHOWN FOR CLARITY (RHS)

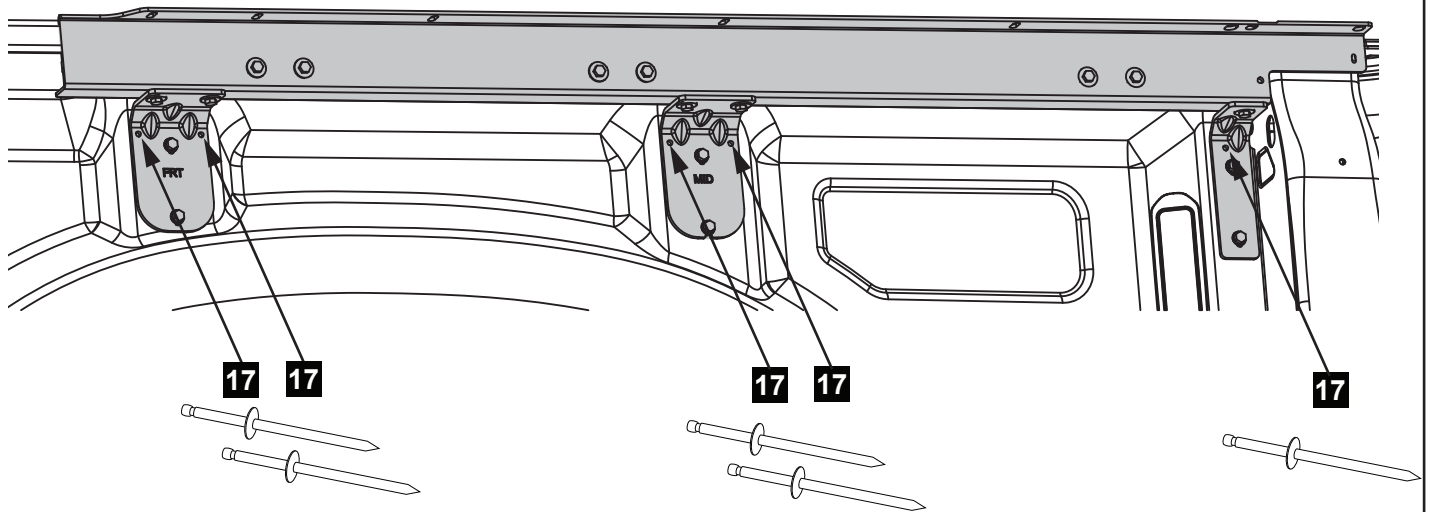

- 1 After running all fitment checks, confirming all functions and running calibration, drill the 5 hole locations using 5mm drill bit. Secure the brackets with rivets as shown. Repeat for LHS.  
NOTE: Apply rust inhibitor to drilled holes.