

INSTALLATION INSTRUCTIONS

EGR ROLLTRAC

MANUAL

Vehicle Model: FORD RANGER PX & MAZDA BT50
Year of manufacture: 2011-2020

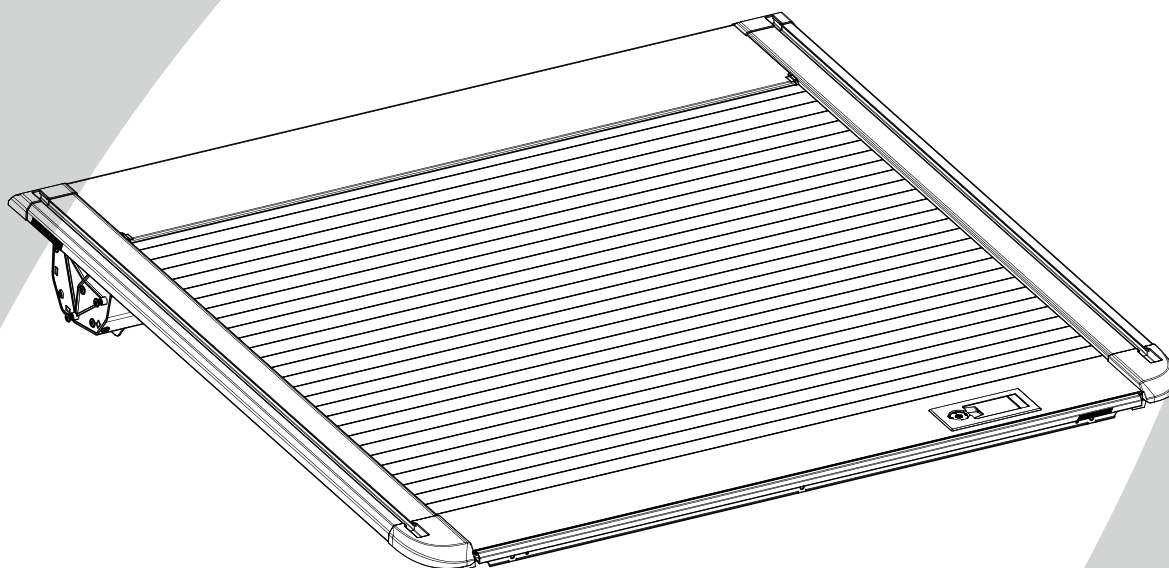

Installation time: 120 minutes (without tubliner)

Caution

- Do not attach EGR RollTrac in a location or by a method not specified.
- Do not use this product for any vehicle make or model, other than those specified in this document.
- Do not remove the plaque or label from this product.
- Do not modify the structure of the EGR RollTrac in any way.

General Notes

- Read through the fitting instructions before installation of EGR RollTrac.
- Always install the accessory following the fitting instructions. Failure to do so may cause damage to the vehicle or the accessory.
- Ensure all recyclable discarded vehicle accessory components and packaging are recycled following local recycling regulations.
- It is always recommended that this accessory is fitted by a qualified Technician.
- Safely store and protect any removed vehicle components.
- Ensure all bare metal surfaces are protected using Automotive Bare Metal Primer and touch-up paint.
- Remove all metal swarf and dust from all vehicle surfaces if surface is used for accessory installation.



Safety Notes

- Check that all work practices comply with safety standards.
- Please wear appropriate clothing and use safety equipment.



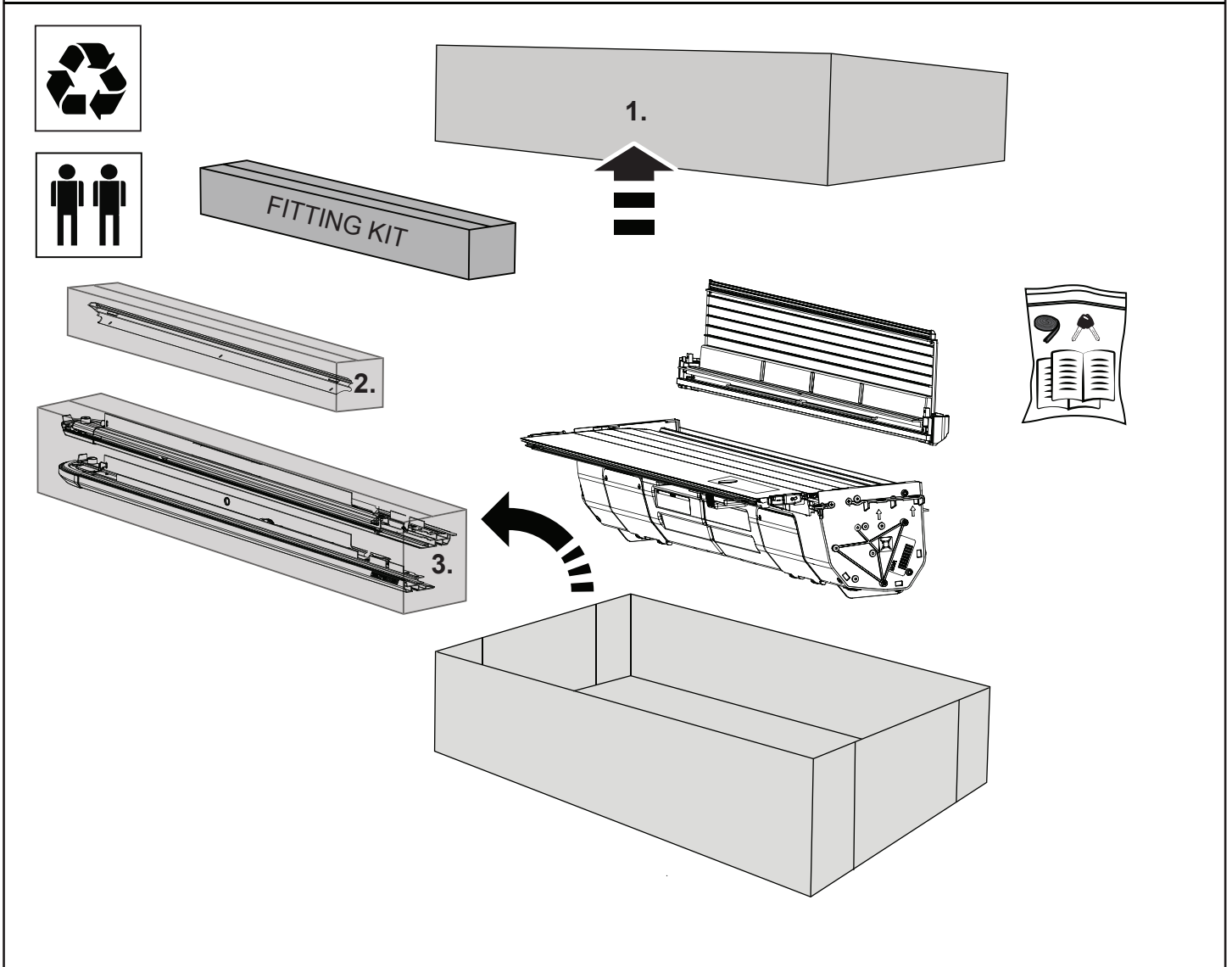
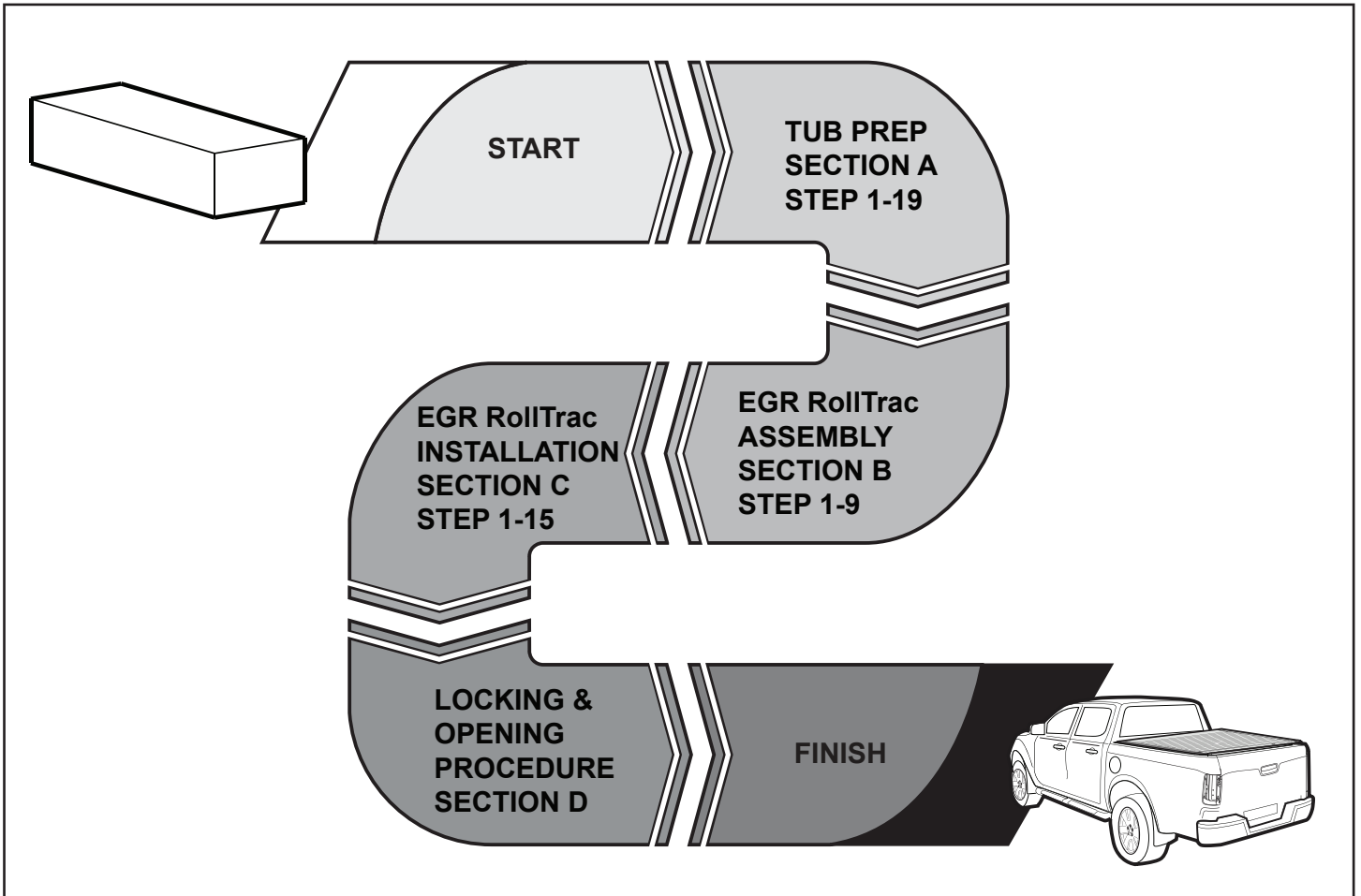

KIT CONTENTS - COMPONENT NUMBER AND QUANTITY

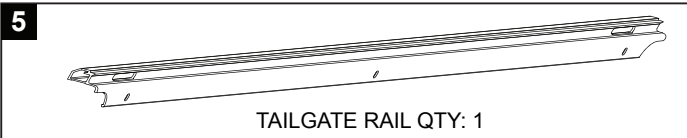
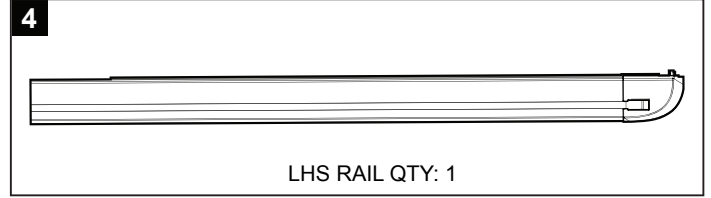
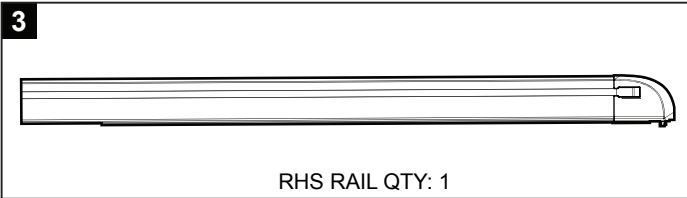
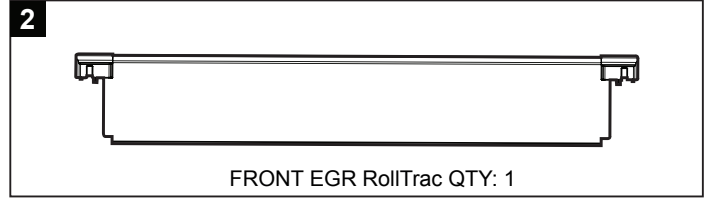
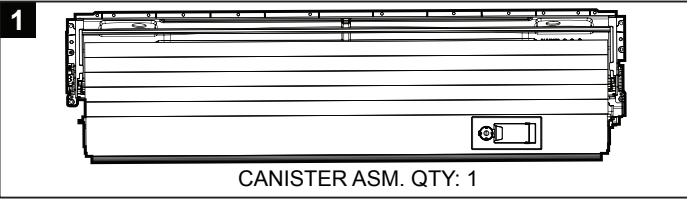

EGR ROLLTRAC FITTING KIT IN BOX

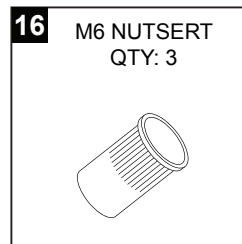
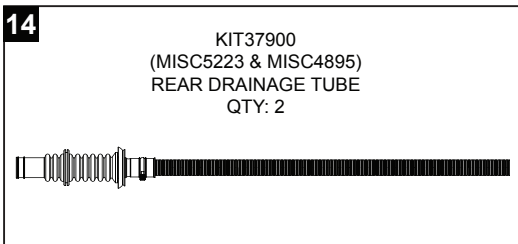
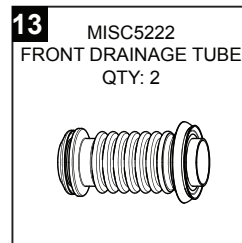
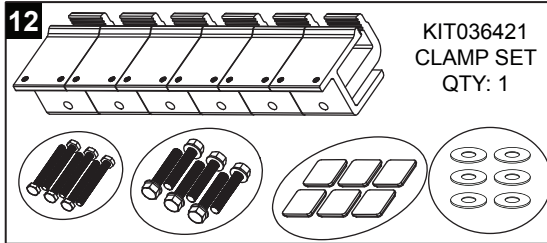
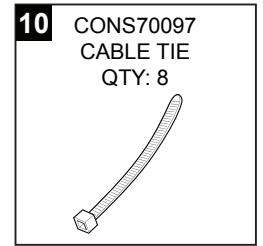
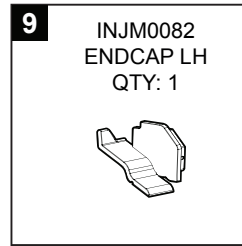
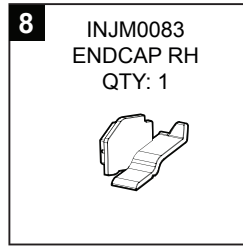

EGR ROLLTRAC FITTING KIT ADDITIONAL ITEMS

18 TAPE0698
TAPE 150X25MM
QTY: 6

19 RUBBER
EXTRUSION
QTY: 2

20 CLAMP FOOT
QTY: 6

21 GROMMET x2

22 TAPE0751
TAPE 3X12X1550MM
QTY: 1

INSTALLATION
INSTRUCTIONS

OWNERS
MANUAL

KEYS x2



TOOLS REQUIRED - NOT SUPPLIED IN KIT

Drill

Holesaw
Ø29mm
Ø38mm
Ø60mm

Centre Punch & Hammer

Drill Stop
Drill Bits
Ø2.0mm
Ø5.5mm
Ø9.0mm

Bobbin Sander Ø60mm

Flat Screwdriver

Phillips Screwdriver

Tape Measure

Scissors

Masking Tape
Fiberglass Tape
Black Cloth Tape

Non-permanent pen

Spanners 8,10,13mm

Ratchet & Sockets
7,10,13mm

Allen Key 4mm

Allen Key 2.5 & 4mm

Torque Wrench

Nutsert Tool

Soapy Water

50/50
Isopropyl Alcohol/Water

ANTI RUST
Rust Inhibitor

Silicone

Trim Removal Tool

Side Cutters

Step Drill Ø9mm

Cutting device
needed to trim
tubliner

Anti-abrasion tape to seal
holes & slots

Silicone Spray

6mm File

Torx set

GLOSSARY:

- 1** Number inside a square indicate part number
- 1** Number inside circle indicate the sequence within a step
- 1** Number inside the hexagon indicate torque instruction

SECTION A

TUB PREPARATION

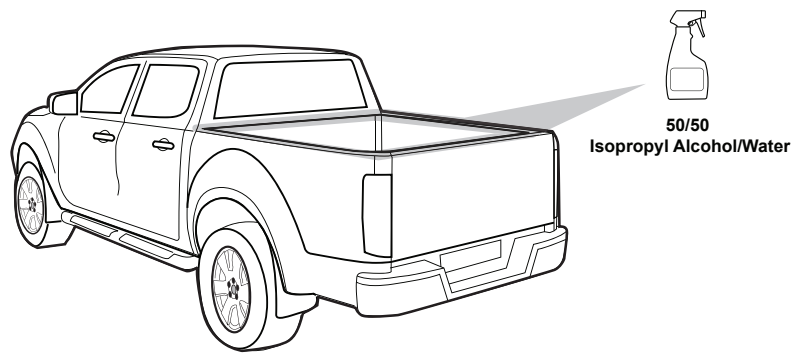
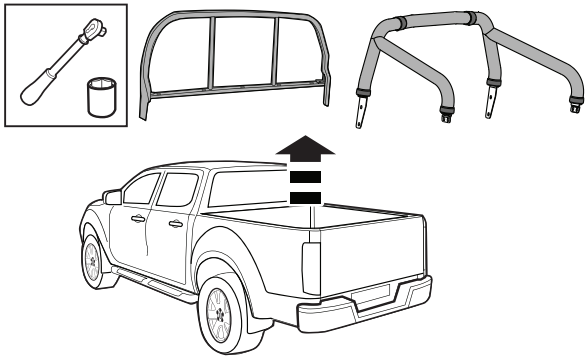

- 1 Carefully remove any accessories (Sports Bars, Cabin Guards, etc.) attached to the tub of the vehicle. Thoroughly wash the vehicle and tub and ensure that all dirt and grease is removed. Allow to dry. Clean the top surfaces of the tub and tailgate with a mixture of Isopropyl Alcohol and Water (50/50) and allow to dry.

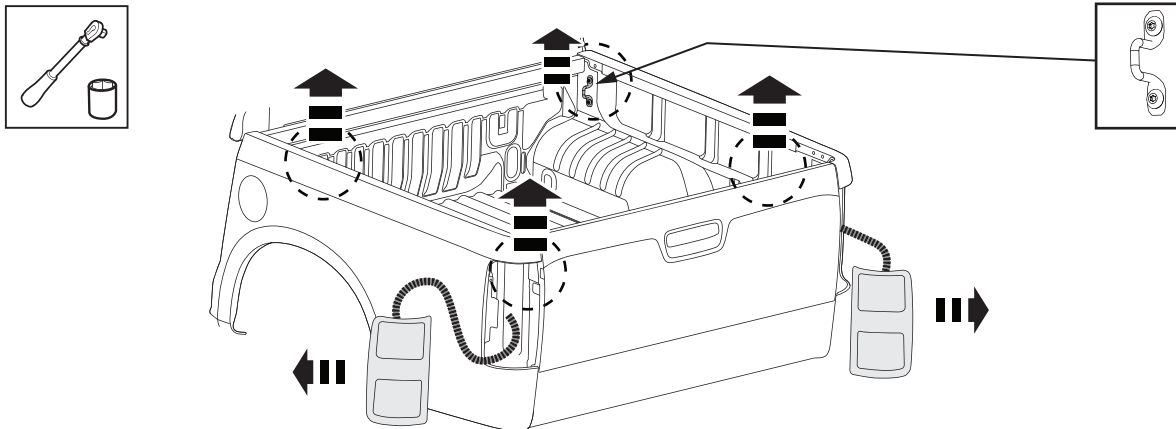

- 2 Carefully remove both Rear Tail Lamps with the appropriate tools and store in safe place. Retain all hardware for re-installation. Remove front and rear tie down hooks.



TUBLINER TRIM NOTE:

Due to variations in tubliners it is strongly recommended that Installers mark up and pre check part fitment in assy and adjust trim lines prior to making final cuts. EGR will not be held responsible for incorrect or inaccurate liner trimming.

FORD RANGER

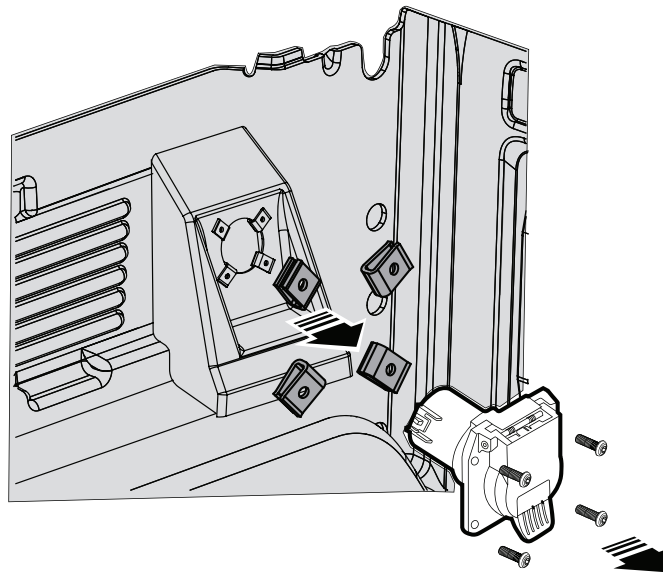

- 3 If the 12v socket is located under the Rolltrac canister, check there is 185mm of clearance downwards from the top of the tub. If trimming is required follow "Socket Trim Notes" in step 4.

SOCKET TRIM NOTES

1

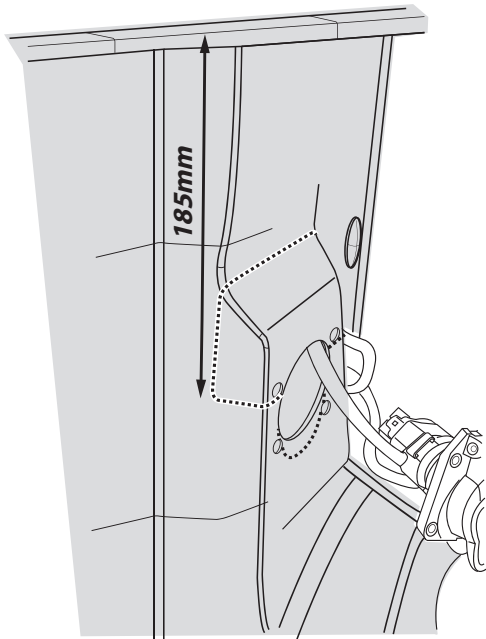
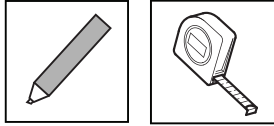

2

Cutting device needed to trim tubliner

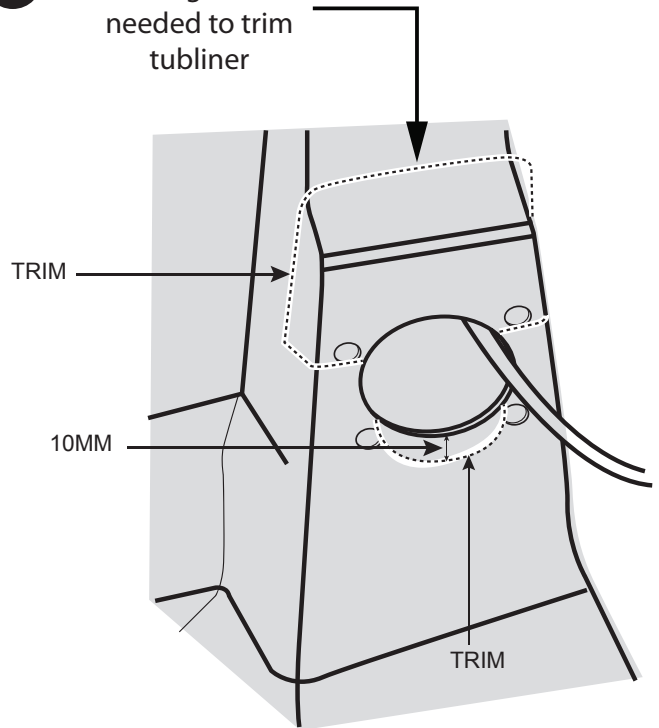

- 4 Remove and retain the power socket if fitted. Please mark trim line 185mm from the top surface of the tub as shown. Trim the tubliner as per the image. Tighten all the fasteners which have been removed in the previous step.

FORD RANGER

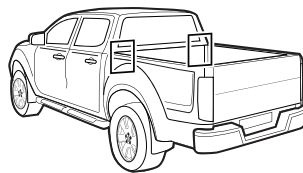
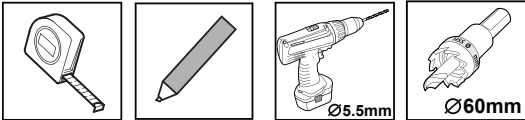

1

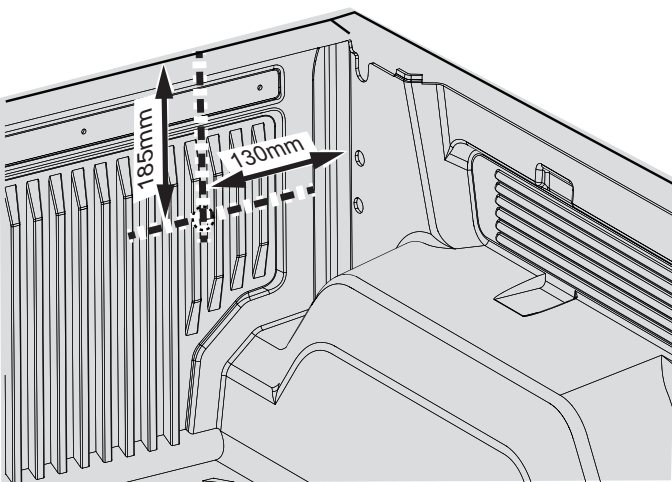

2

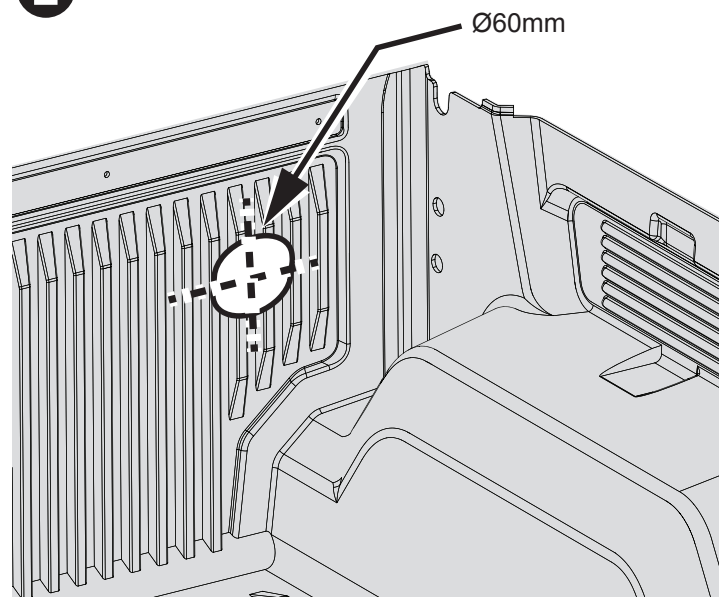

- 5 Measure and mark up the positions for the front Drain Tubes on both sides. Centre punch the locations and drill through the tub and tubliner (if fitted) with 5.5mm drill as shown. Drill out the front pilot holes in the tubliner with 60mm holesaw. RHS shown, repeat for the LHS. Note: If needed remove the tubliner.

FORD RANGER

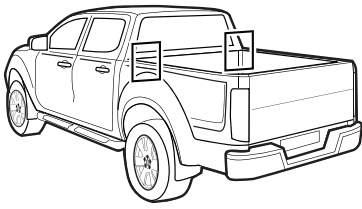
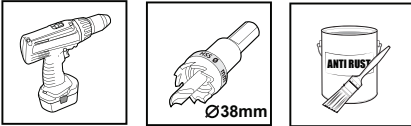

FRONT OF TUB
RHS SHOWN LHS MIRROR

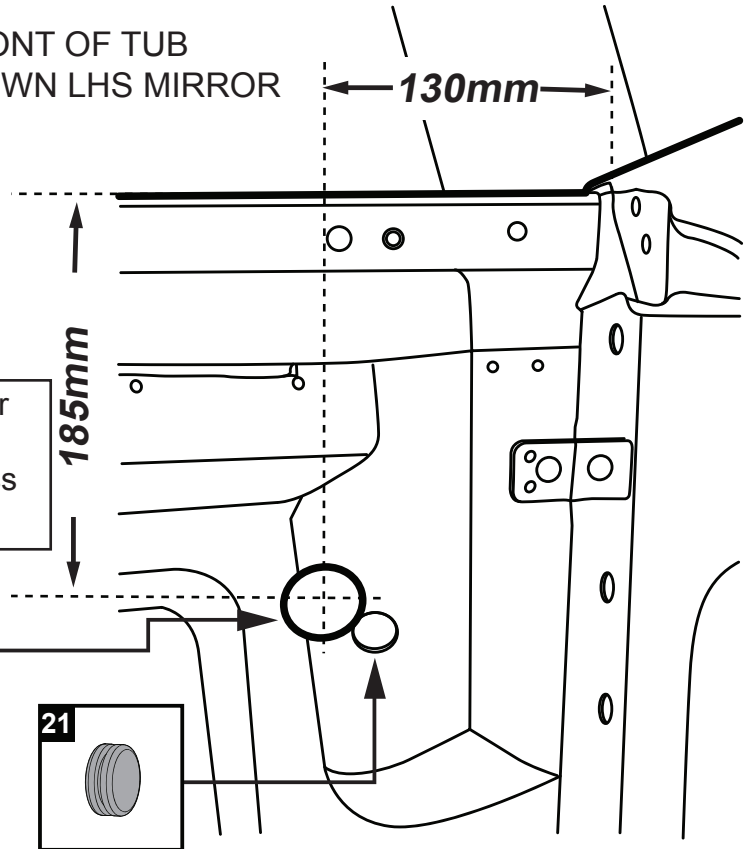

ATTENTION: Ensure that the diameter of the hole does not exceed 38mm. Larger hole size will lead to water ingress into the tub

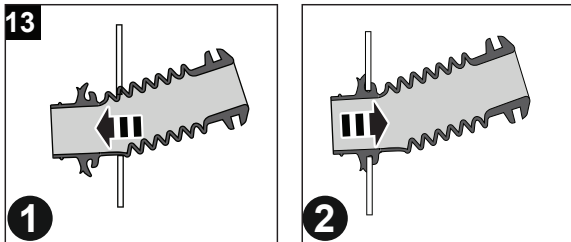

INSTALL FRONT DRAIN TUBES TO TUB

- 6** Mark the position of the front drain holes in the tub front panel and drill with 38mm holesaw. Clean all burrs and coat the exposed metal with a suitable rust preventative (not supplied). Fit rubber grommets into the existing holes in the tub as shown. Refit tubliner and tie down points. Fit the front drain tubes (13) to the tub.

FORD RANGER

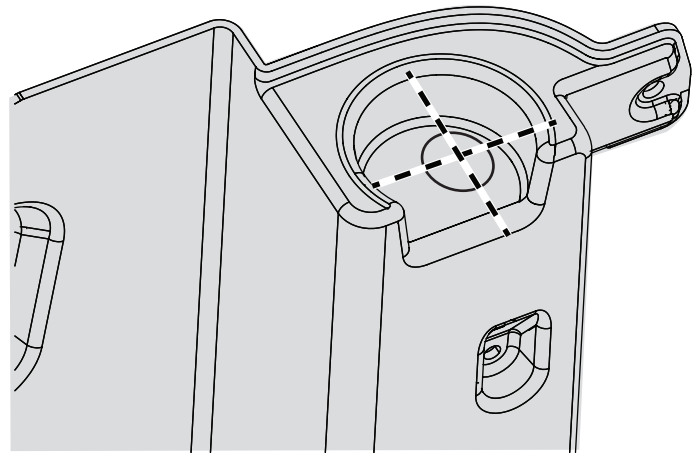
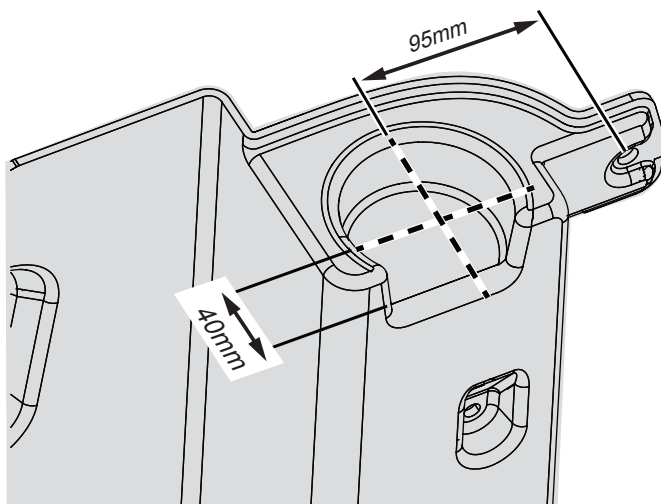
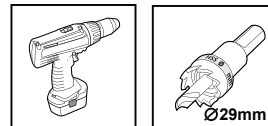
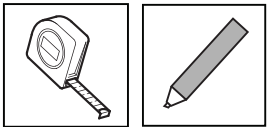

- 7** Measure and mark up the positions for the rear Drain Tubes on both sides of the tubliner if fitted. Drill the locations with 29mm holesaw.

FORD RANGER

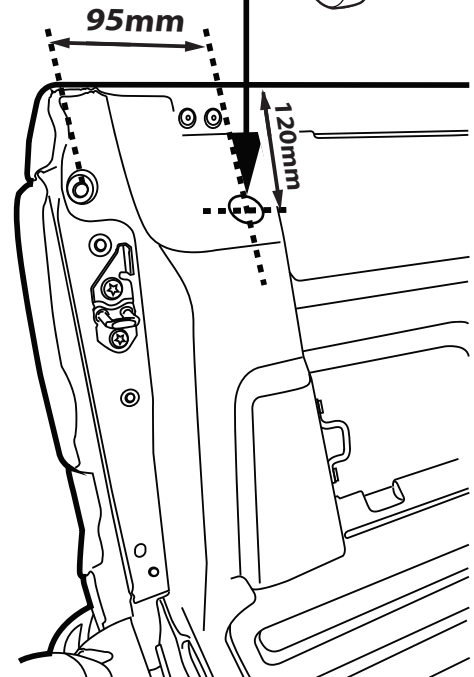
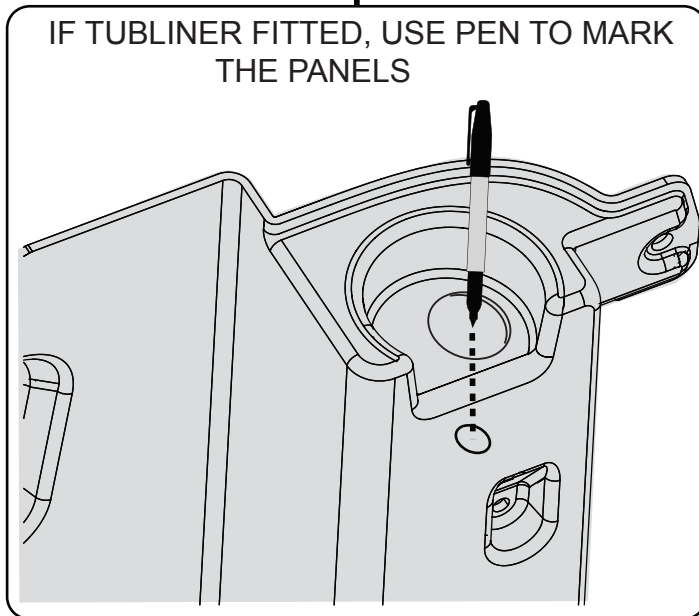
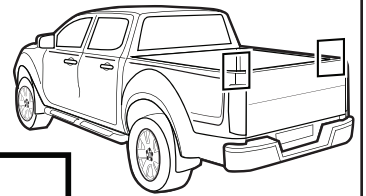
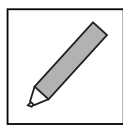
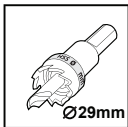
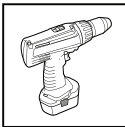

- 8** Mark the position of the rear drain holes in the tub rear panels, centre punch the hole and drill with 29mm holesaw. If no tubliner fitted, use the dimensions provided. Clean all burrs and coat the exposed metal with a suitable rust preventative (not supplied).

MAZDA BT50

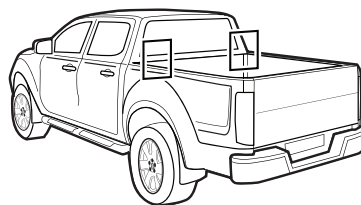
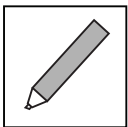
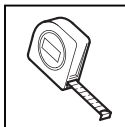

FRONT OF TUB TUBLINER MARKING

LHS

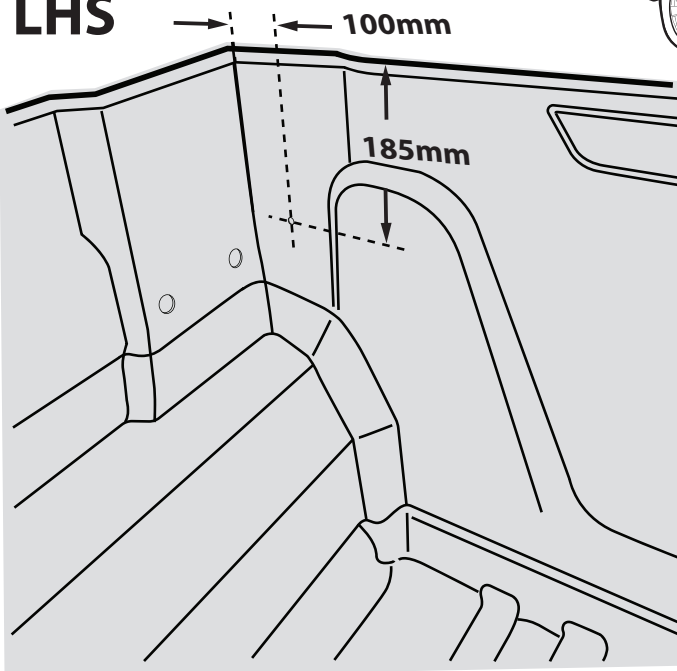

RHS

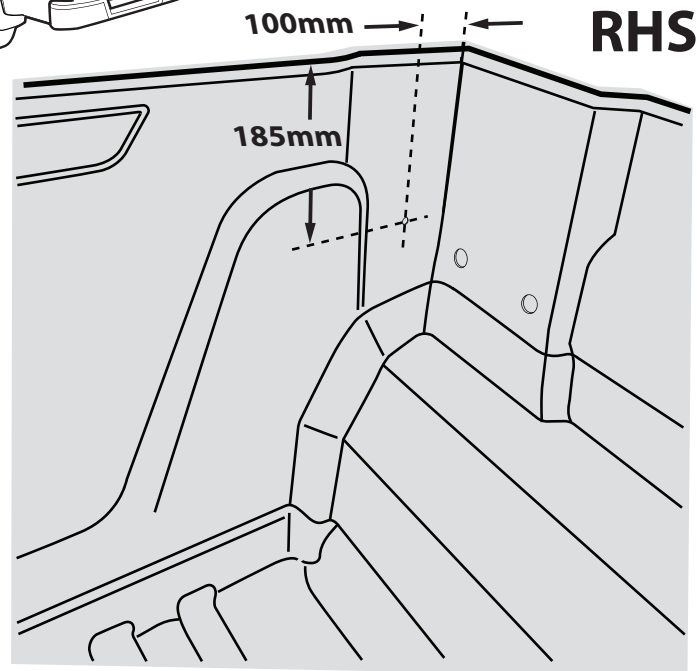

- 9** Measure and markup the positions for the front tubliner drain tubes on both sides. Centre punch the locations and drill through the tub and tubliner (if fitted) with 5.5mm drill.

MAZDA BT50

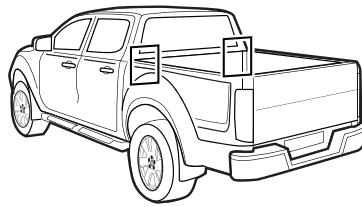
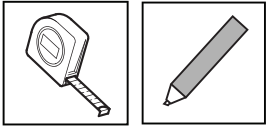

FRONT OF TUB TUBLINER MARKING

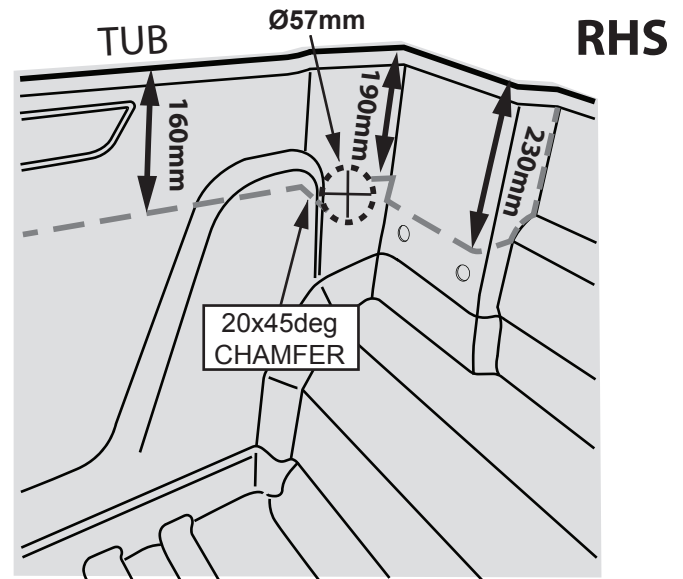
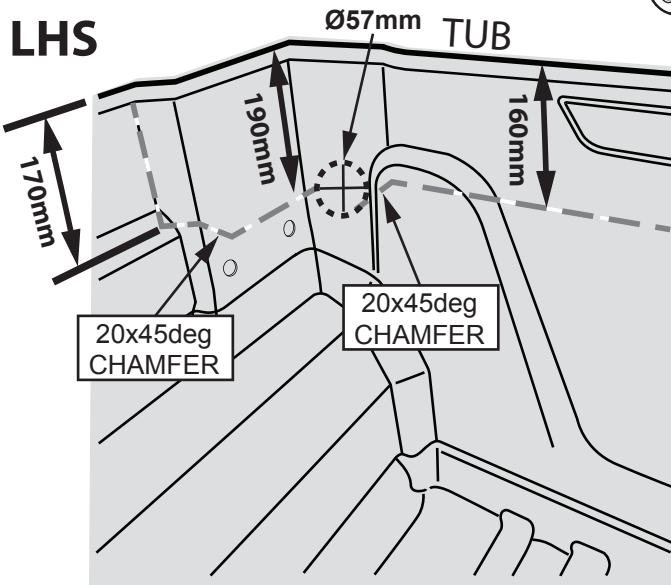

- 10** Measure and mark up the positions for the front tubliner trim on both sides. Mark up the front drain tubes 57mm diameter using the pilot holes as center. **NOTE:** All measurements are taken from the tub.

MAZDA BT50

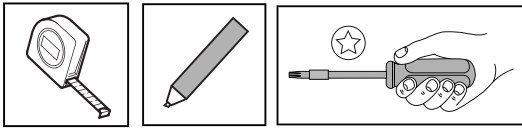

REAR OF TUB TUBLINER MARKING

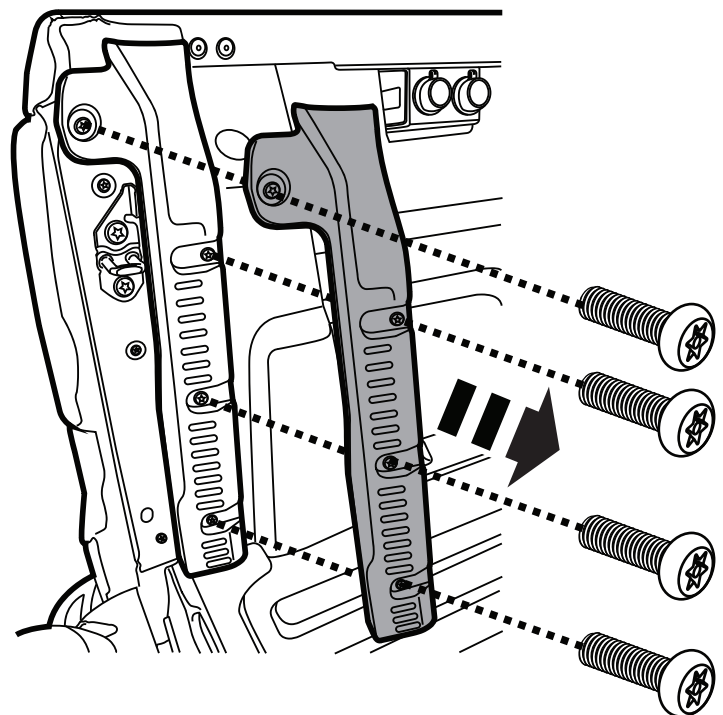
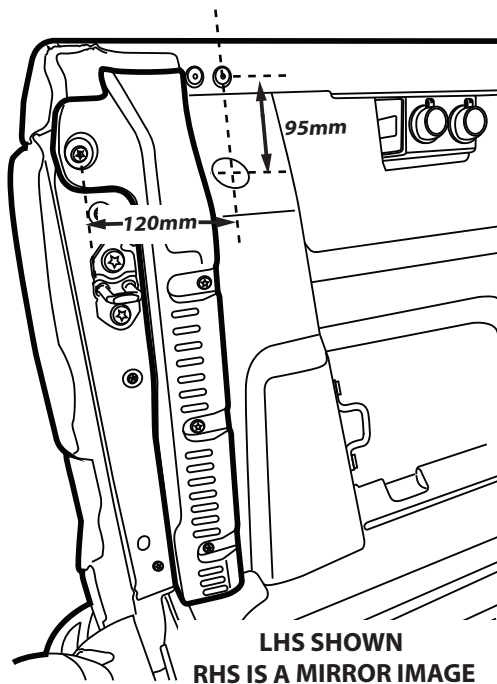
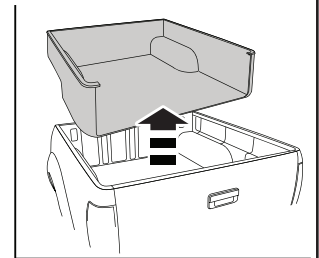

- 11** Mark the tubliner for the rear drain tubes as shown. Remove the rear tub plastic trim and remove the tubliner. Retain all hardware.

MAZDA BT50

Cutting device
needed to trim
tubliner

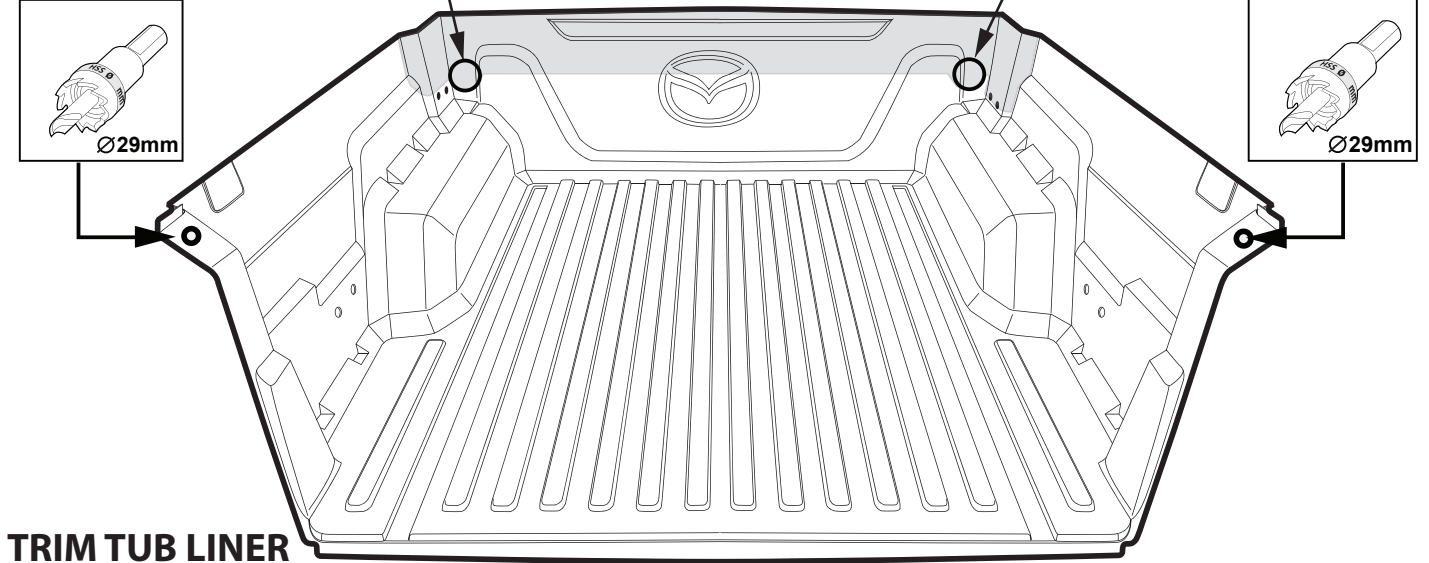
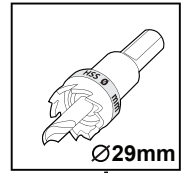
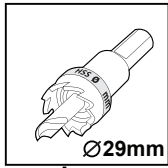
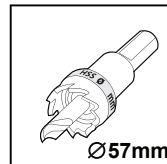
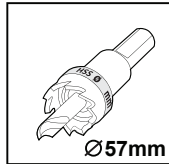

TRIM TUB LINER

12 Drill the front drain tubes with a 57mm dia hole saw first using the mark up. Trim the front part of the marked tubliner using cutting device following the mark up. Drill the rear drain holes with 29mm hole saw. Clean all sharp edges.

MAZDA BT50

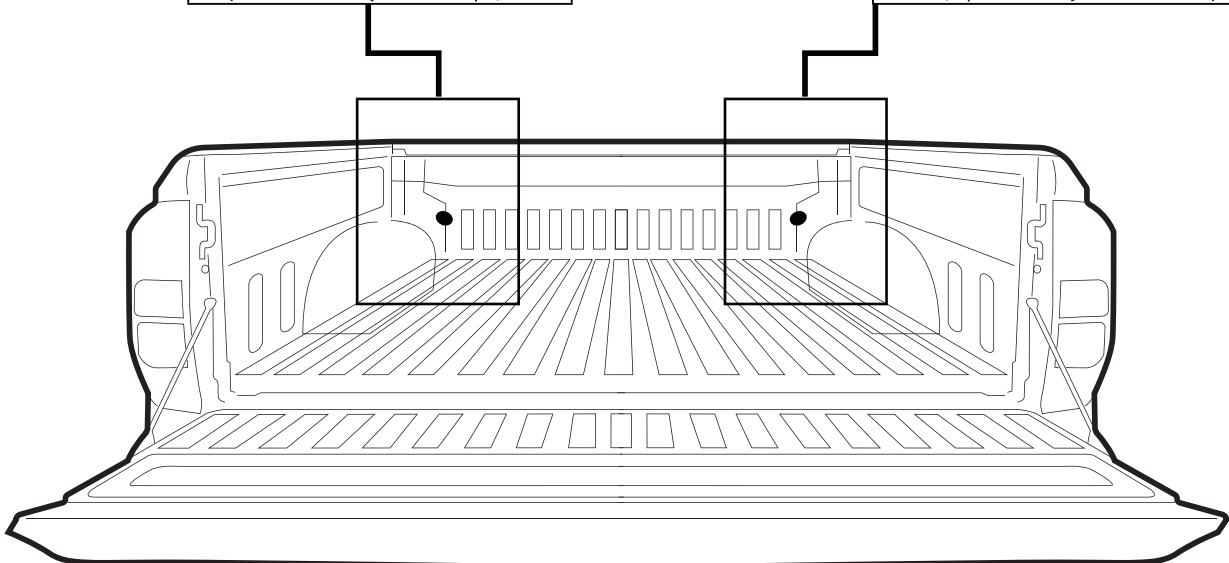
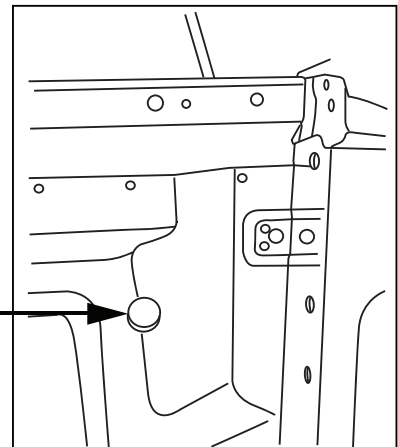
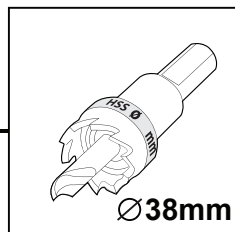
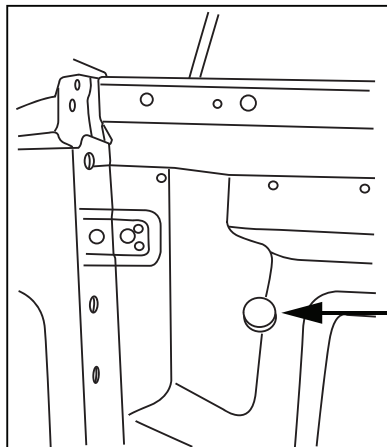

13 Drill out the pilot holes with 38mm hole saw. Clean all burrs and coat the exposed metal with a suitable rust preventative (not supplied).

MAZDA BT50

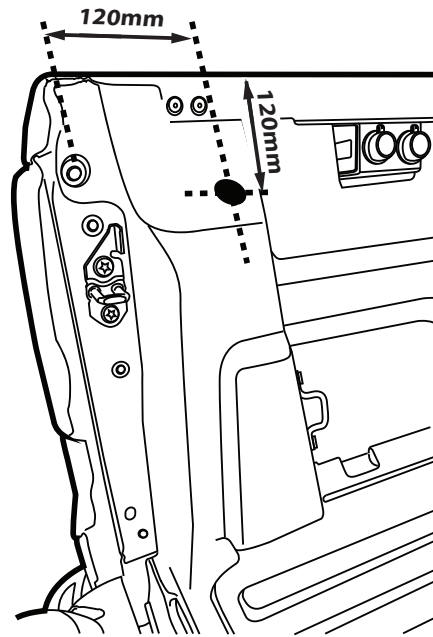
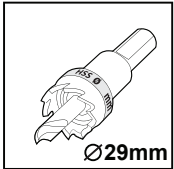

LHS SHOWN
RHS IS A MIRROR IMAGE

- 14** Mark the position for the rear drain holes and drill with 5.5mm drill first. Drill out with the pilot holes with 29mm hole saw. Clean all burrs and coat the exposed metal with a suitable rust preventative (not supplied).

MAZDA BT50

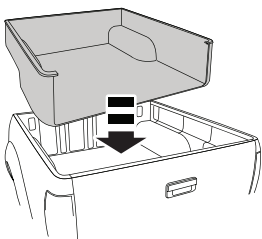
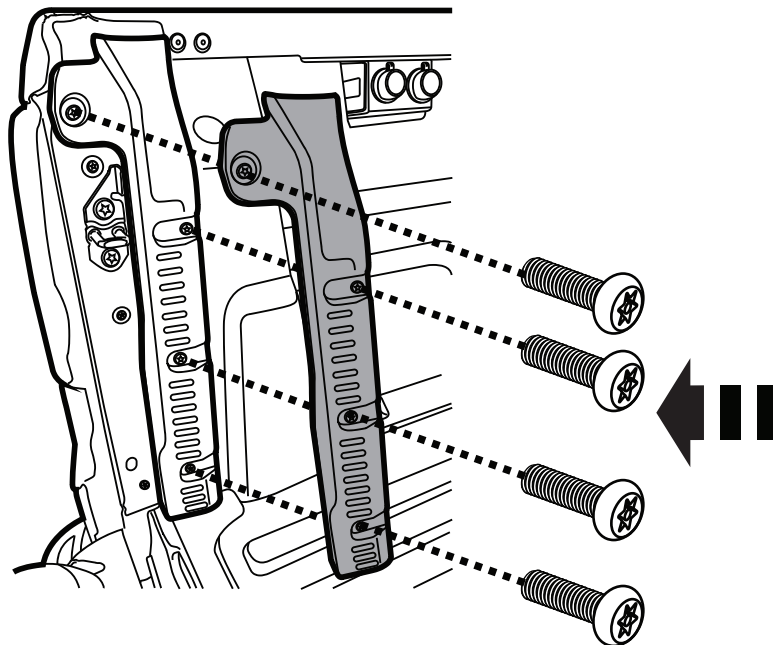
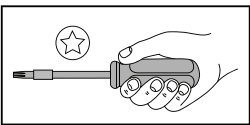

- 15** Refit the tubliner and secure at the rear with the plastic trim. Refit both rear and LH front tie down points.

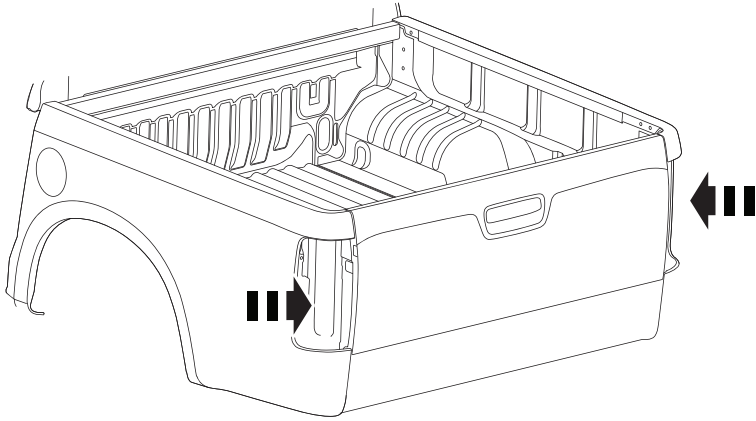
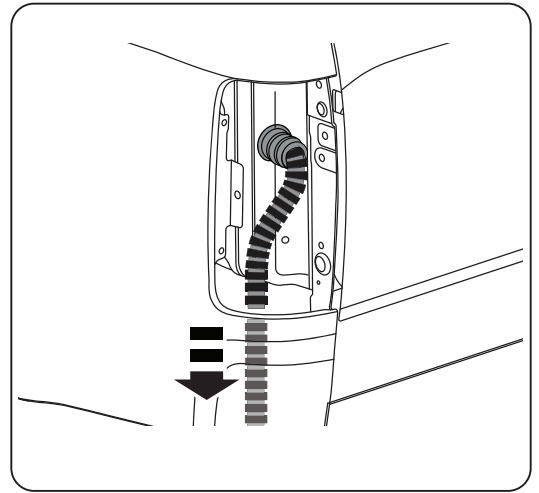
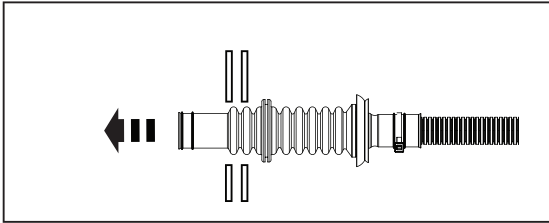

16 Install the rear drain tubes and water conduit (14) into the gap in the LHS and RHS tail lamp recess.

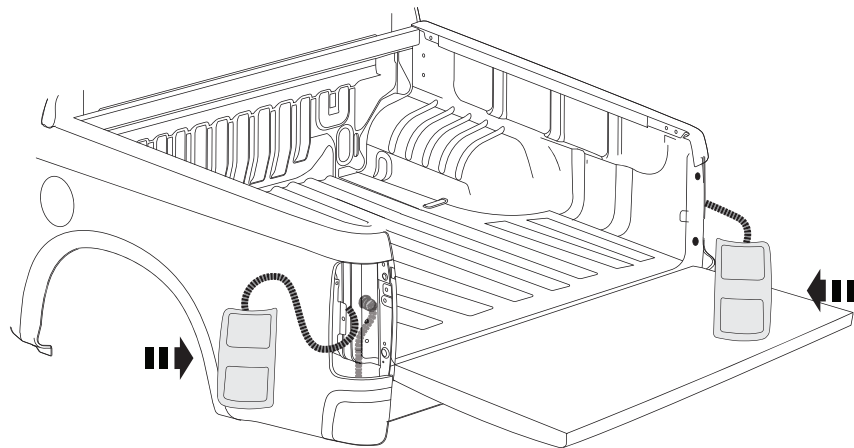
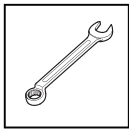

Pull the connectors
not the cable

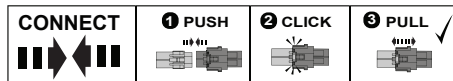

17 Re-connect the rear tail lamps with the previously removed hardware.

FORD RANGER & MAZDA BT50

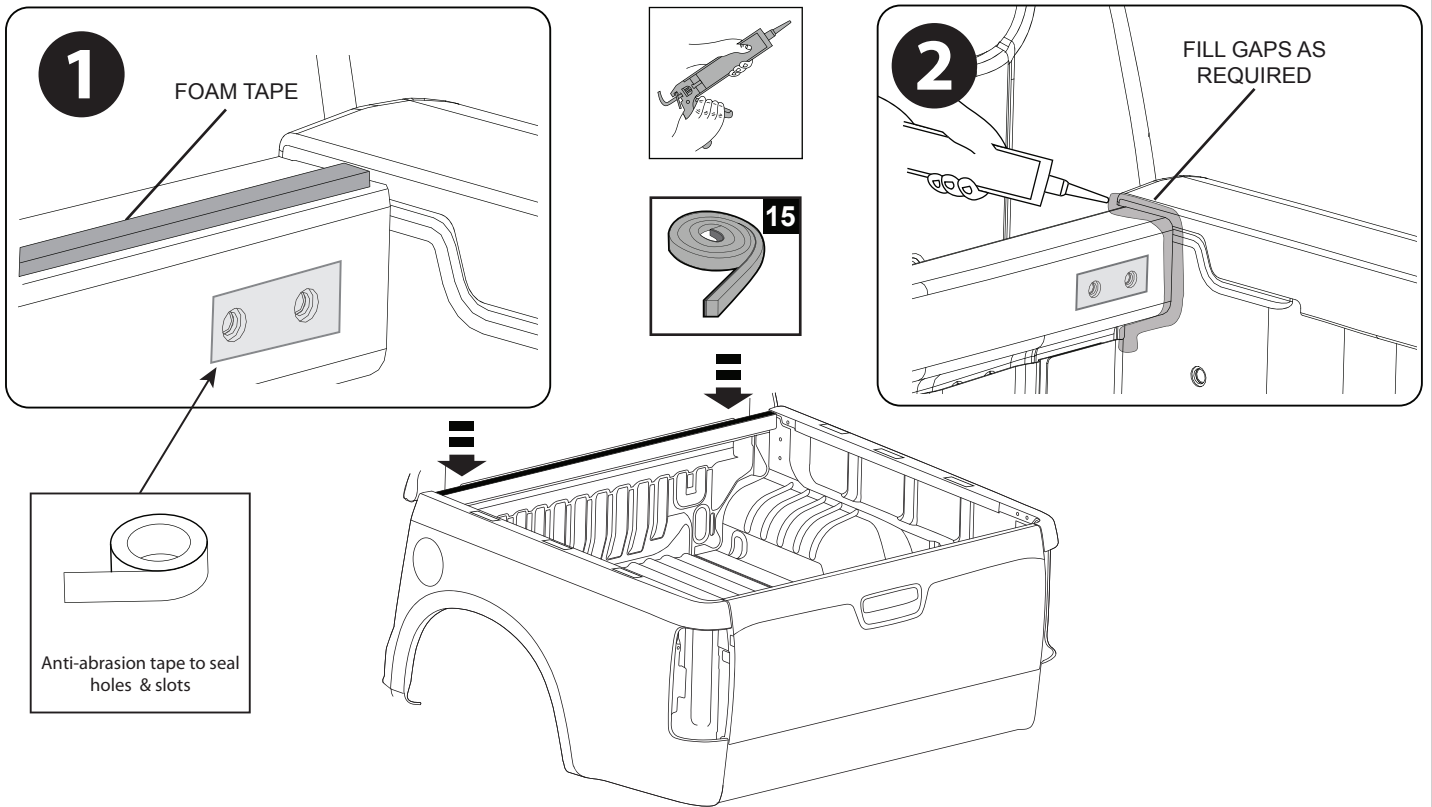

- 18** Clean the tub top with isopropyl alcohol (50/50) and use primer. Allow to dry. Apply foam tape (15) to the top of the front tub rail close to the rear edge of the rail as shown. To prevent water ingress, apply a bead of silicone (non-acidic) to gaps such as between the front rail and the side rail as shown. Holes in the tub from any removed accessories should be covered using tape or silicone.
NOTE: Ensure the Silicone bead transitions smoothly between front and side rail.

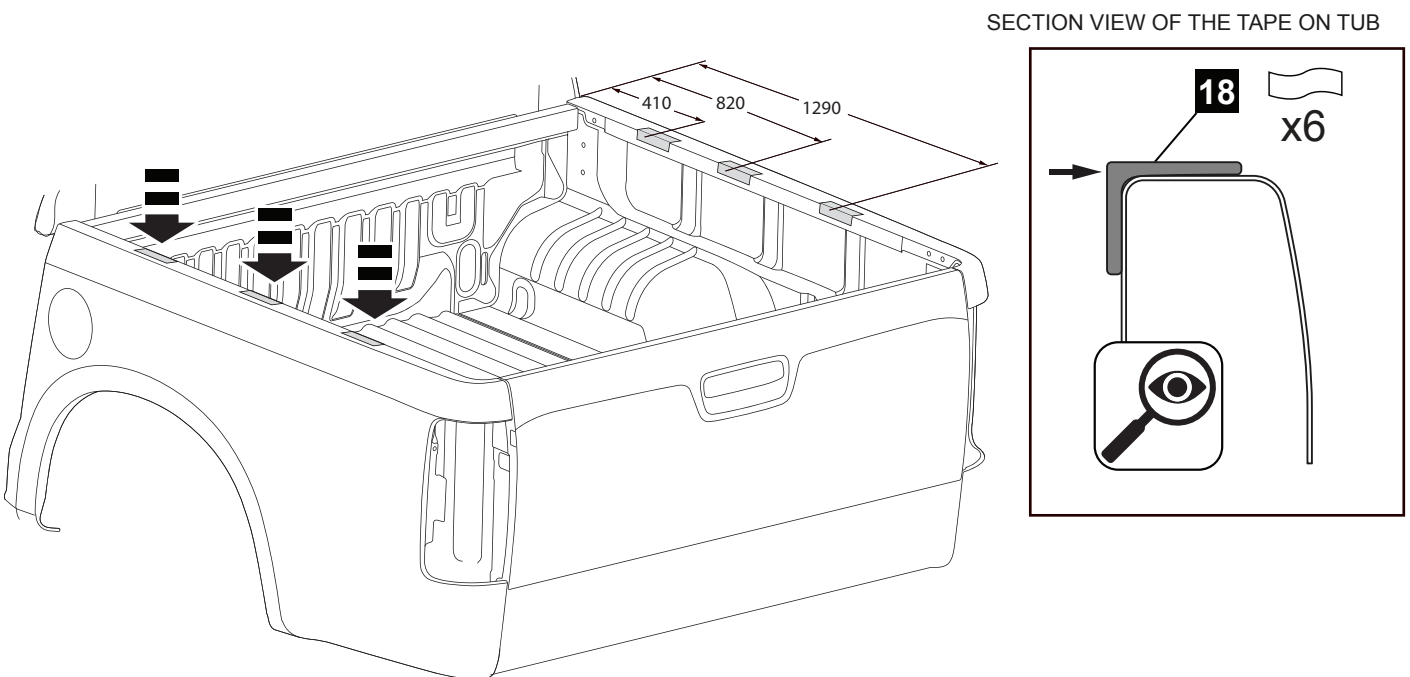

- 19** Clean top of the tub. Measurements taken from front of the tub to the centre of each tape, as per the diagram. Adhere 6 Abrasive Protection Strips (18) to the top of the tub at clamp locations. Position the tape so that it is aligned with the inside wall of the tub as shown.



DURING ASSEMBLY PROCEDURE SUPPORT AT CENTRE OF CANISTER ONLY, PLACE ON TOP AND BASE CARTON (OR SIMILAR), COVER WITH FOAM BLANKET. TO AVOID SCRATCHING POWDERCOATED SURFACES.

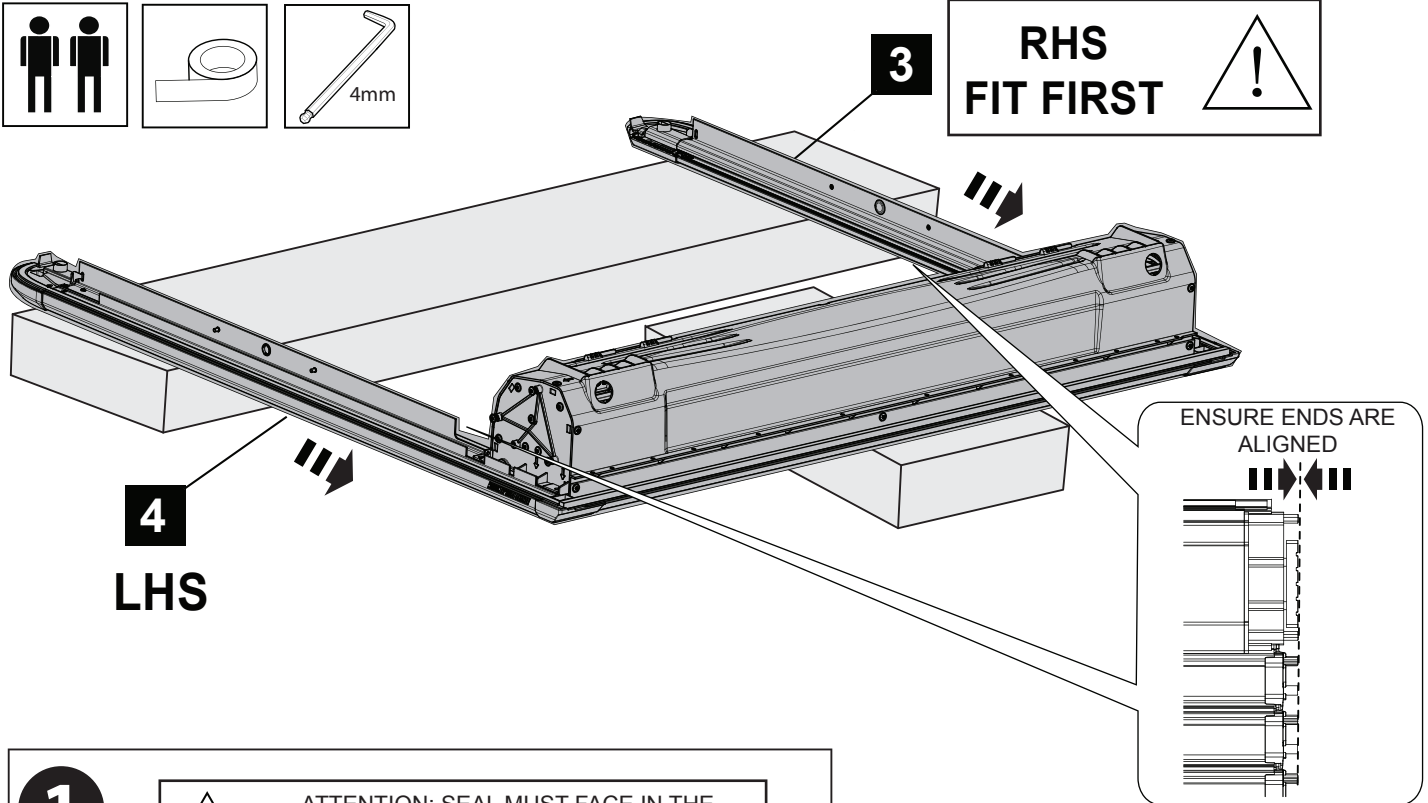
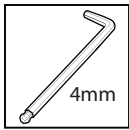
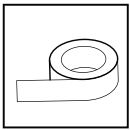

3 RHS FIT FIRST

4 LHS

1



ATTENTION: SEAL MUST FACE IN THE DIRECTION AS SHOWN. WARRANTY VOID IF ASSEMBLED INCORRECTLY.

HOLD SEAL FLAT USE CLOTH TAPE

RHS SHOWN

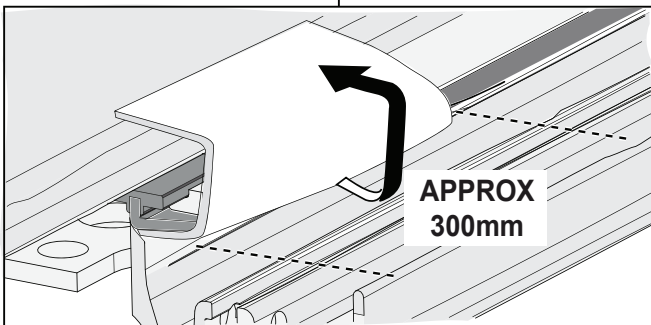
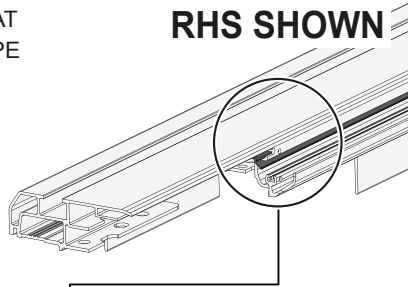
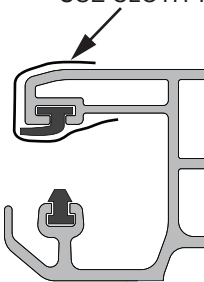

1 Place the canister (1) on two protected boxes as shown, ensure hand rail and slat ends are aligned. Tape up the seal on the Side Rail (3) as shown. **IMPORTANT:** Carefully align and slide the rail over the handrail and canister endplate taking particular care to ensure that the siderails are slid straight and no undue force is applied to the rail. Details in following steps.

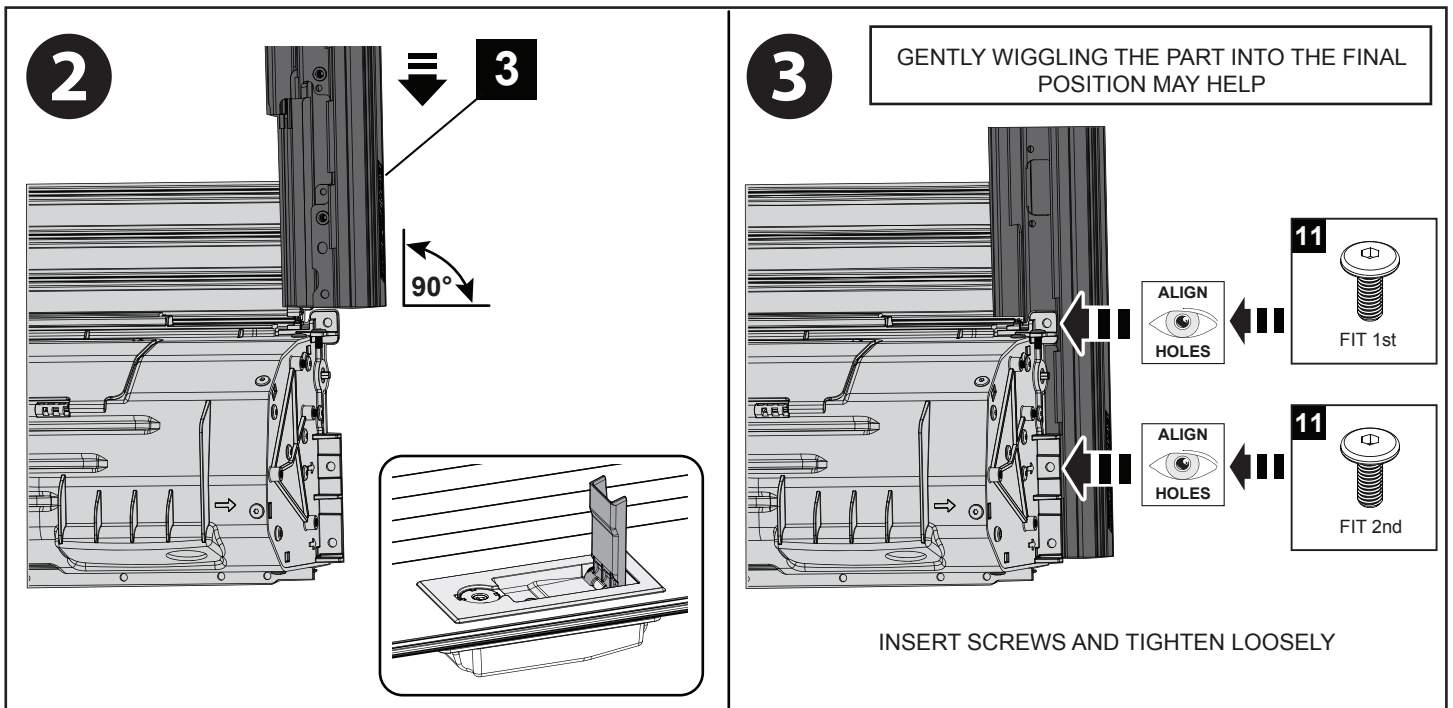

2 Pull hand rail to expose 3 slats. Fully open handle to retract brake pads. Slide the Rail over slat ends and onto endcap location pins. Align the holes and secure loosely with two screws (11). Do not tighten. Repeat for LHS Rail (4).

! DURING ASSEMBLY PROCEDURE SUPPORT AT CENTRE OF CANISTER ONLY, PLACE ON TOP AND BASE CARTON (OR SIMILAR), COVER WITH FOAM BLANKET. TO AVOID SCRATCHING POWDERCOATED SURFACES. **!**

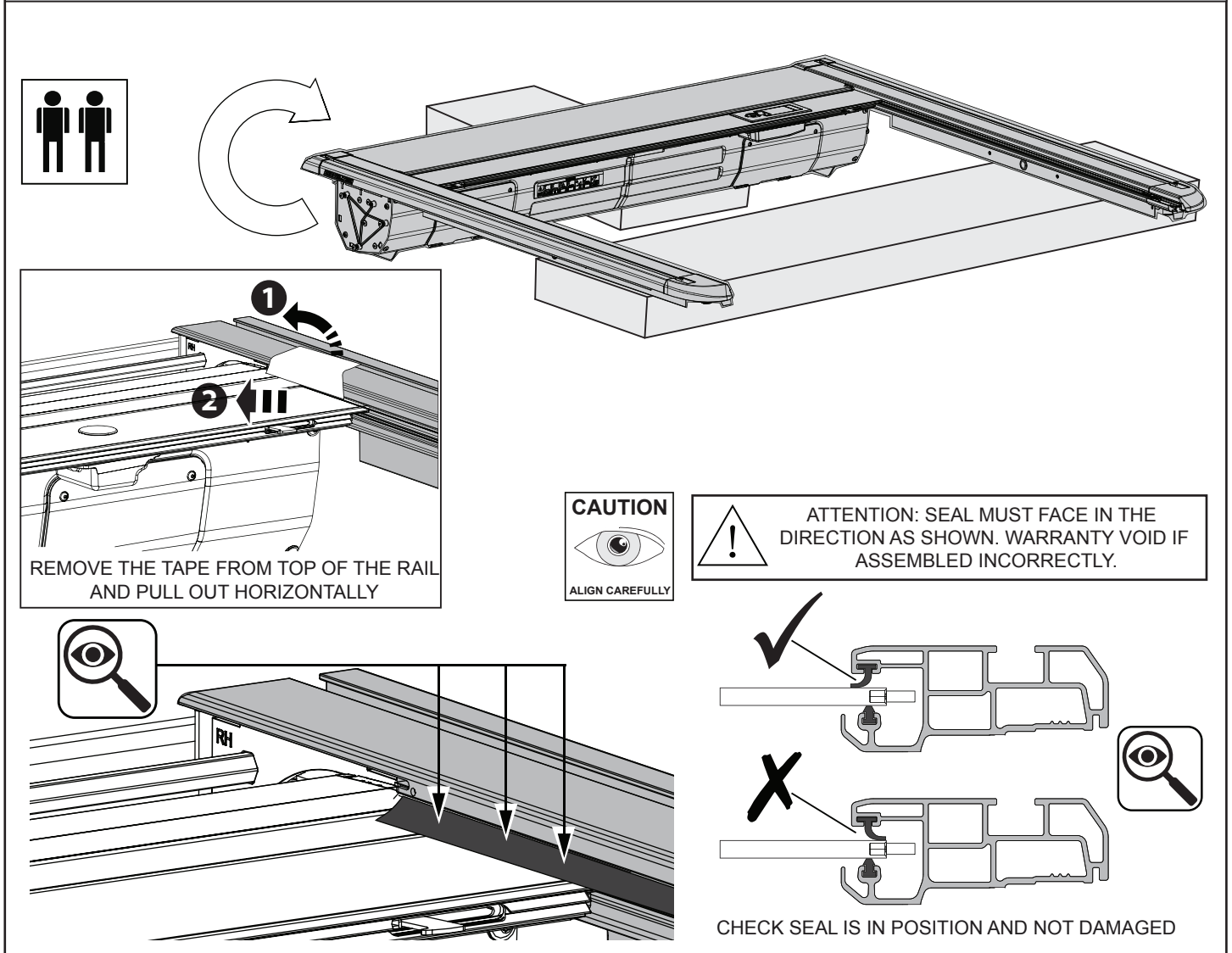

3 Carefully lay the assembly over onto a protected surface. Remove the tape holding the rubber seal and check the seal position as shown. Repeat for LHS Rail (4)

SIDE VIEW

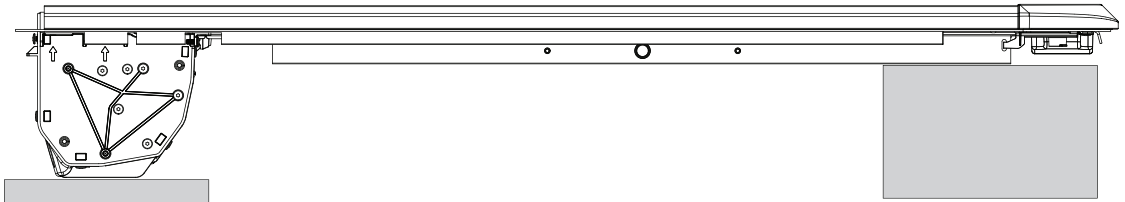
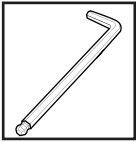

REAR VIEW

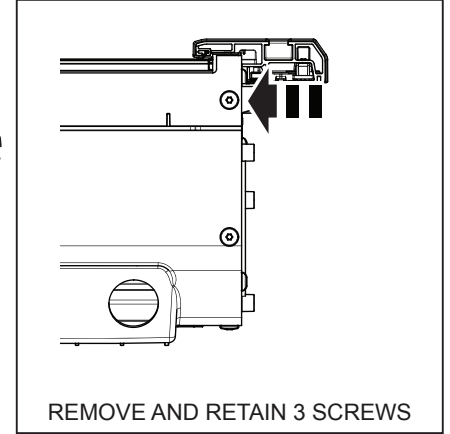
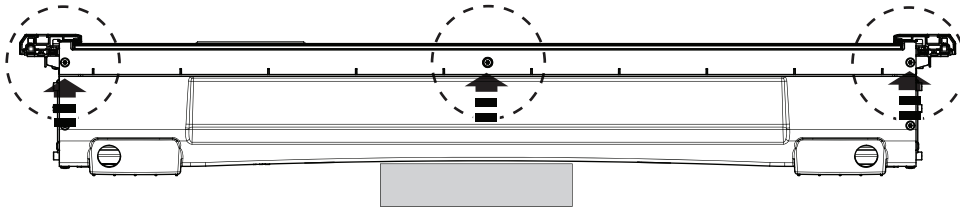

REMOVE AND RETAIN 3 SCREWS

- 4** Remove the 3 pre-fitted screws (11) from the rear of the EGR RollTrac which will be used to secure the Front Plate (1) to the assembly. Ensure the product is not scratched or damaged when laying flat.



CAUTION



DO NOT DAMAGE



ATTENTION: REMOVE FOAM TAPE END FROM THE SIDE RAIL BEFORE FITTING INTO FRONT COVER

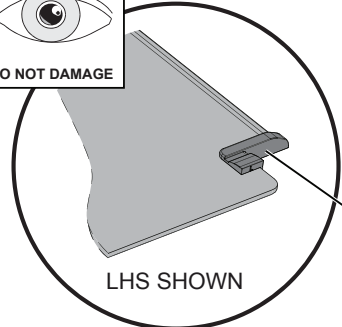

LHS SHOWN

REMOVE TAPE SECURING THE RUBBER CORNER SEAL

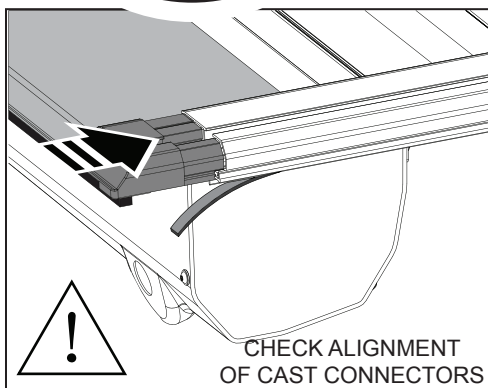

CHECK ALIGNMENT OF CAST CONNECTORS

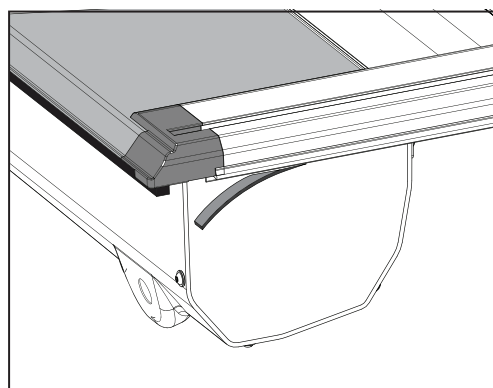

- 5** Slide the Front Plate (2) over the canister and into the side rail channels ensuring that the foam side rail tape is pulled out of side rail and the small rubber corner seal on the RHS and LHS of the front plate are not damaged. **IMPORTANT:** Spray the front cover edge with soapy water to allow it to slide easily into the sides, twisting side rails outwards will also help.

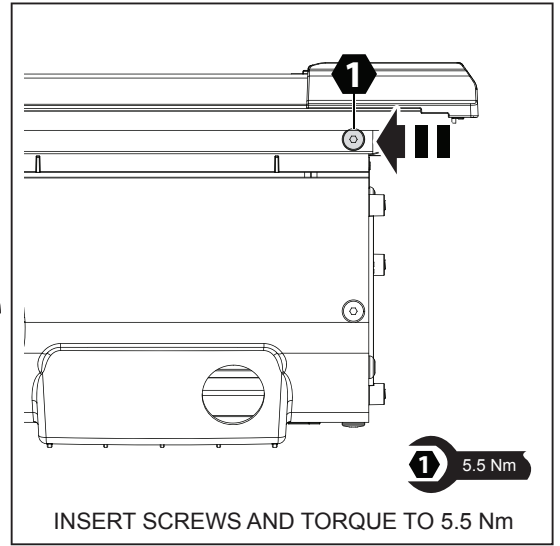
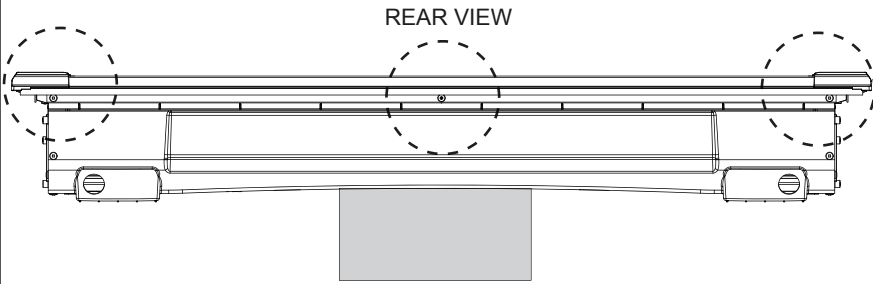
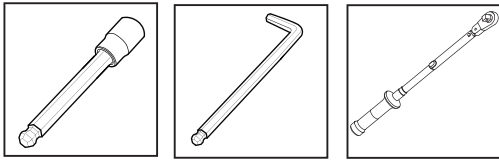

6 Using the 3 screws removed from Step 4, screw the Front Plate (2) to the Canister Assembly (1) and torque to 5.5 Nm.

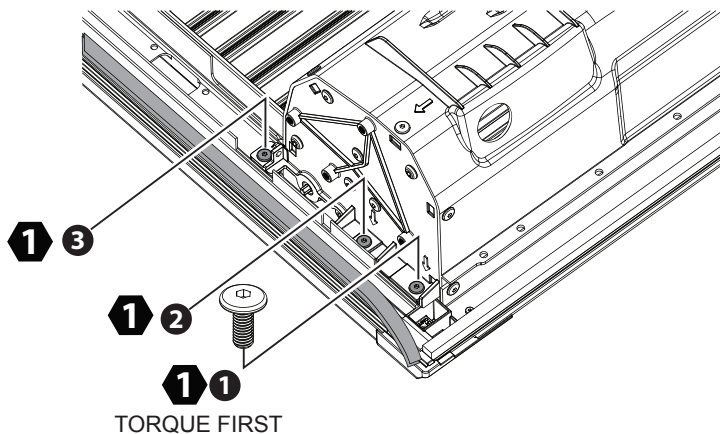
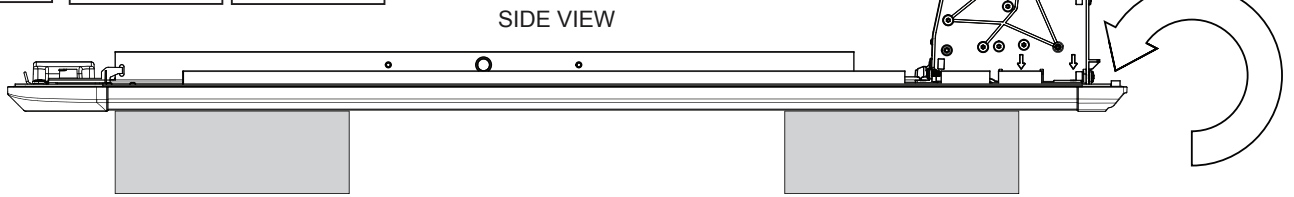
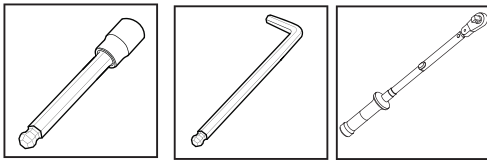

LHS SHOWN - RHS IS A MIRROR IMAGE

7 Carefully flip the assembly over onto a flat protected surface which will not damage the EGR RollTrac or scratch the paint work. Install the 2 screws (11) at the most rearward position first through the front cover to the side rails and torque to 5.5Nm followed by the remaining 4 screws (11) and torque to 5.5Nm.

LHS SHOWN - RHS IS A MIRROR IMAGE

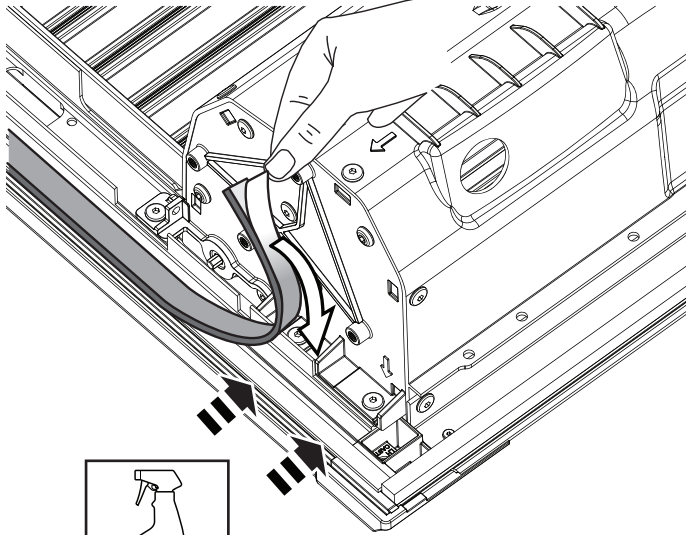

CLEAN WITH ALCOHOL FIRST

LHS SHOWN - RHS IS A MIRROR IMAGE

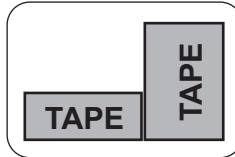
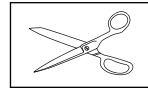
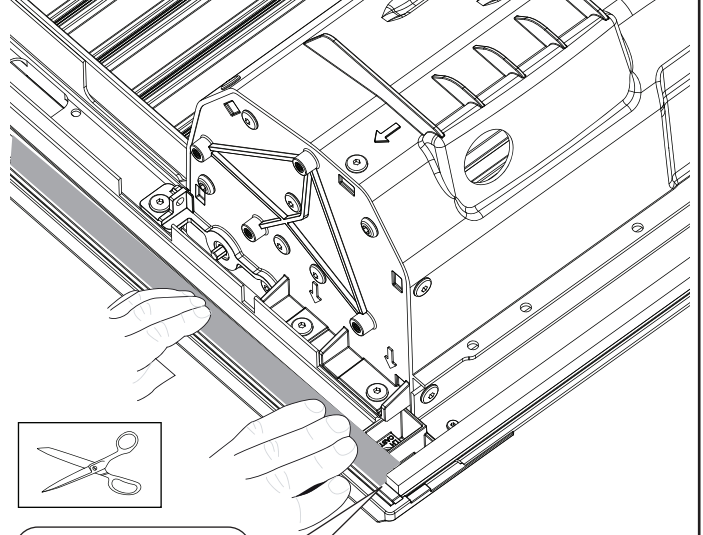

TAPES MUST CONTACT

8 Clean powder coated surface first with alcohol spray. Trim foam tape length to ensure the end will butt against front cover seal - avoiding any gap. Peel the protective liner from the foam tape, adhere to the channel in the side rail, Press down firmly to secure. Repeat on RH side rail.

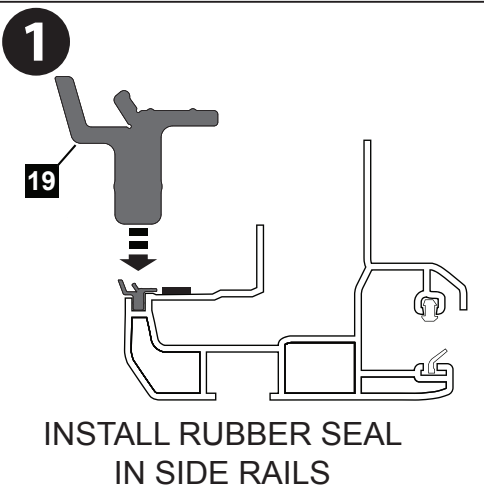

INSTALL RUBBER SEAL IN SIDE RAILS

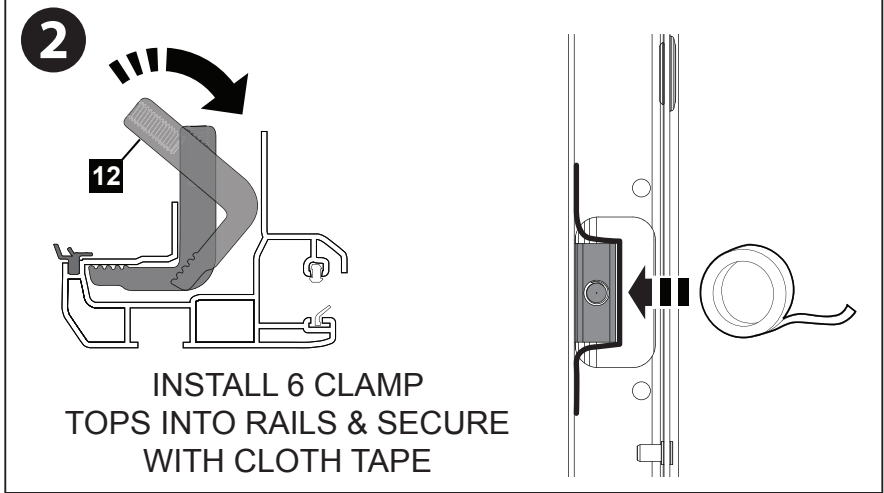

INSTALL 6 CLAMP TOPS INTO RAILS & SECURE WITH CLOTH TAPE

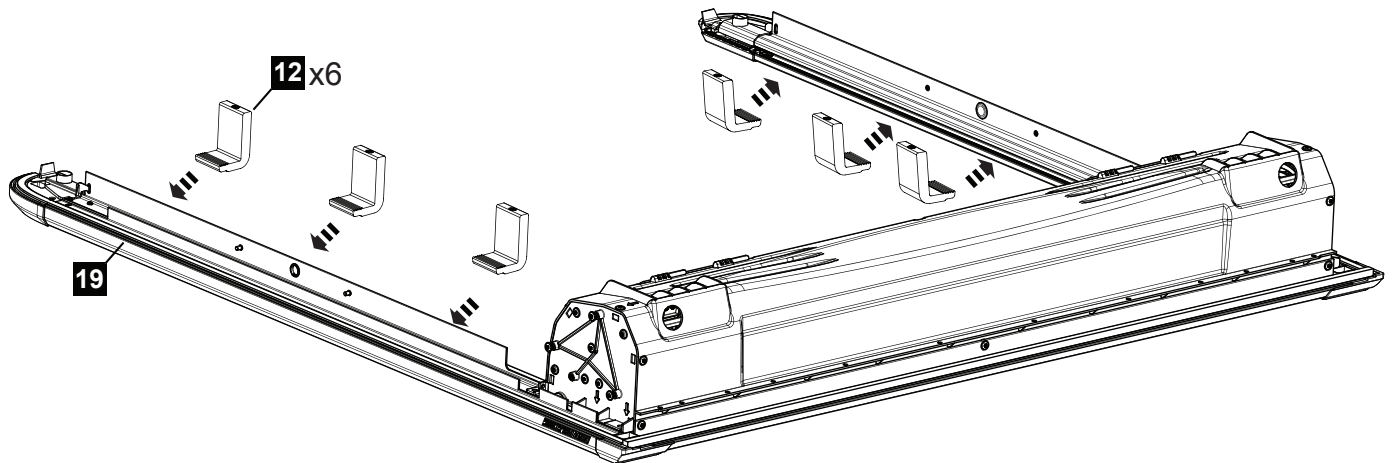

9 1) Install the six Clamp Tops (12) into the LHS and RHS side rails and secure with cloth tape to temporarily hold in position.
2) Install the Rubber Perimeter Seal into each side rail and ensure seal is firmly seated (note the seal orientation).

1 (VIEW INSIDE)

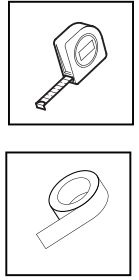
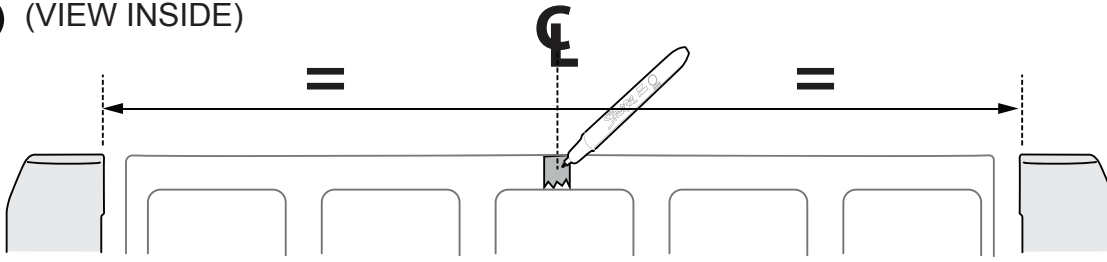

MARK CENTRELINE ON THE TAILGATE
(MEASUREMENTS TAKEN FROM INSIDE TUB AS SHOWN)

2 (TOP VIEW)

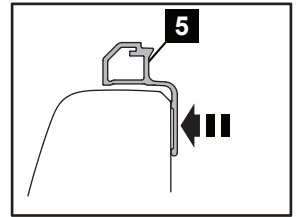
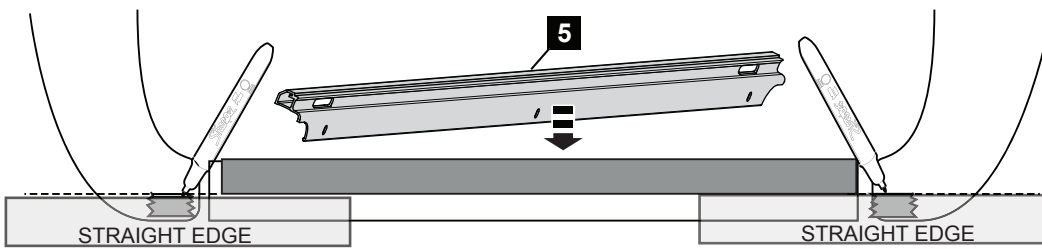

MARK LINE ON LHS AND RHS

- 1** Measure the tailgate opening distance, determine the centre point and mark on a strip of tape placed on the tailgate as shown. Install and centralise the Tailgate Rail (5) in position, ensuring the rail is sitting flush up against the tailgate. Place a straight edge as shown and mark a line on each side of the tub on the masking tape. Remove the Tailgate Rail (5).



HEAVY

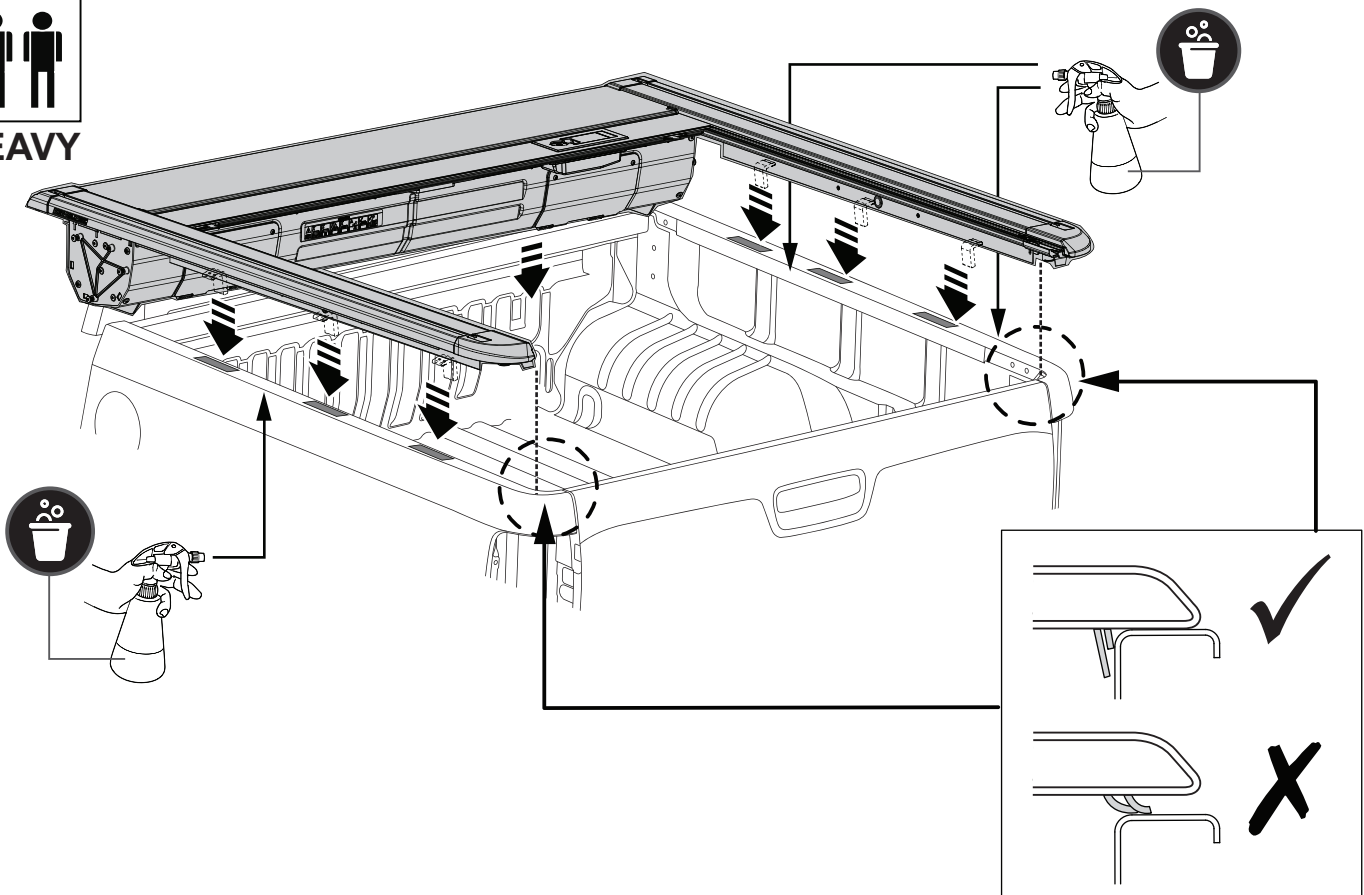

- 2** Spray the top surface of the tub liberally with a soapy water solution to enable the EGR RollTrac to slide easily. Using two people to lift the EGR RollTrac from both sides and carefully lower it onto the tub. **NOTE:** You may have to lift the LHS of the EGR RollTrac and use packer to aid connection. Ensure rear seals are sitting vertically as illustrated.

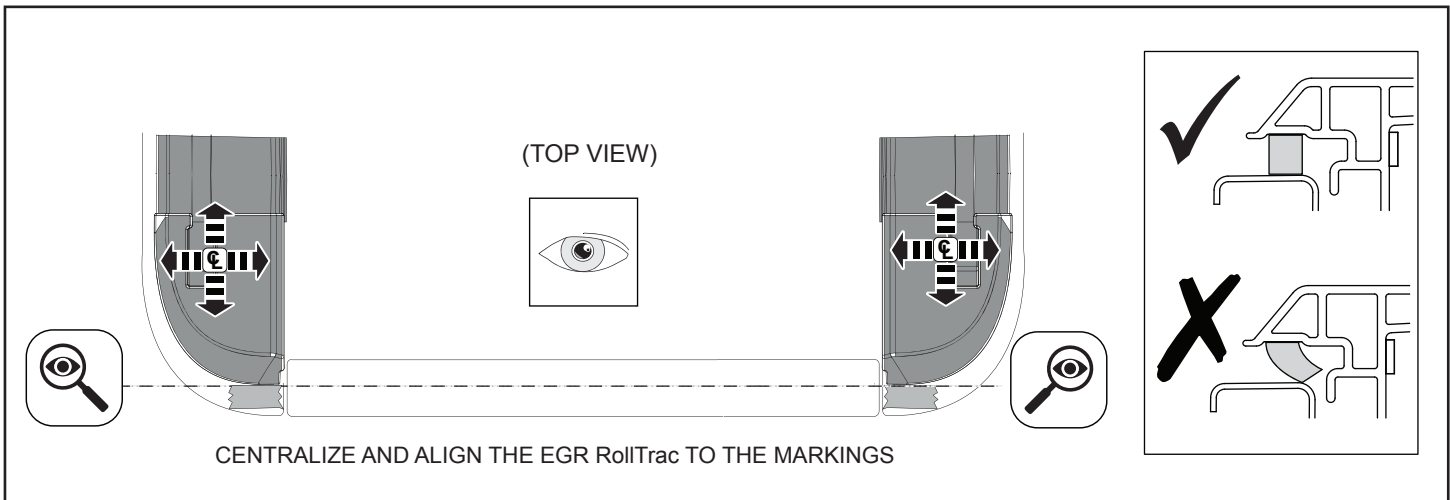

3 Adjust the EGR RollTrac so that it is aligned with the previous markings as shown. Ensure seals are not deformed by lifting EGR RollTrac and dropping vertically on tub.

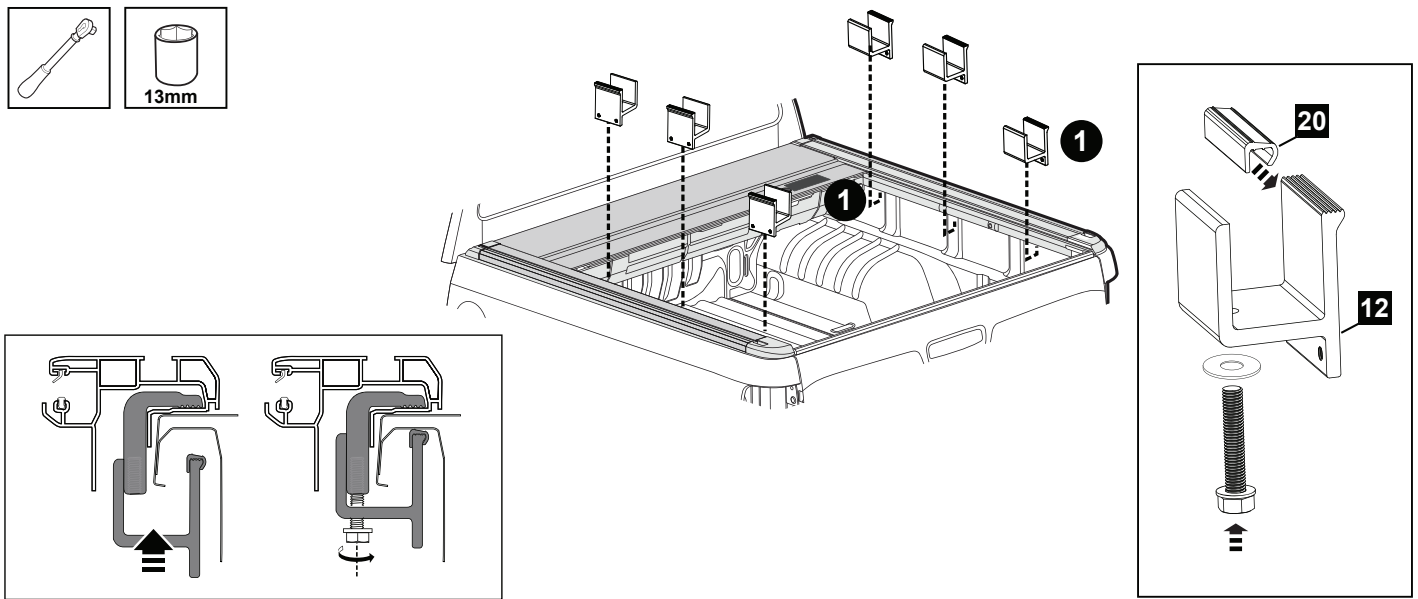

4 Slide the clamp feet (20) onto the clamp base and loosely install the LHS and RHS clamp bases (12). DO NOT TIGHTEN. IMPORTANT: Ensure to install washers as supplied in the kit.

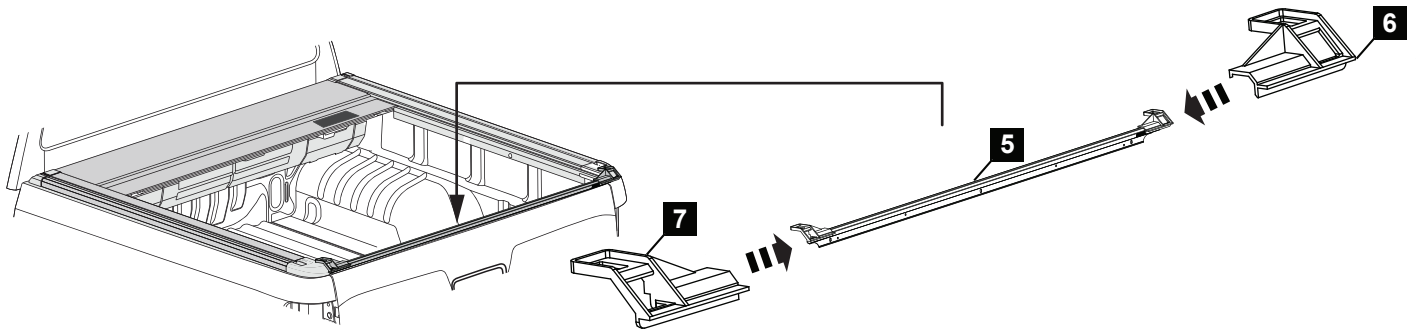

5 Open the tailgate. Assemble jigs to the tailgate rail, position on rear corners of the cover. Gently close tailgate.

REAR TOP VIEW

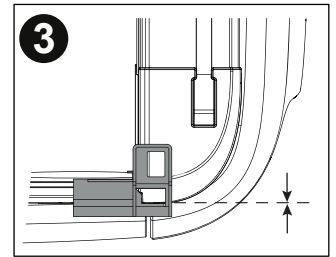
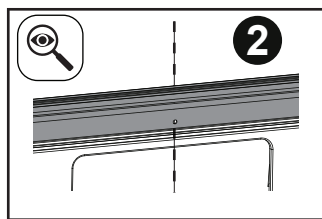
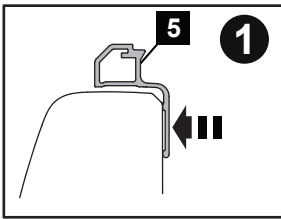
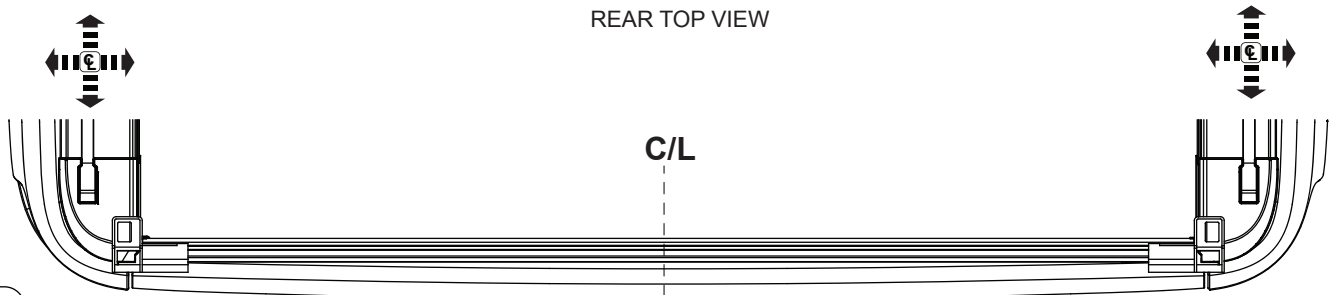

6 Press tailgate rail firmly against the tailgate. Check and adjust side to side by aligning the centre slot of the tailgate rail with pre marked center line. Check front to back position of EGR RollTrac on tub using jigs as a guide.

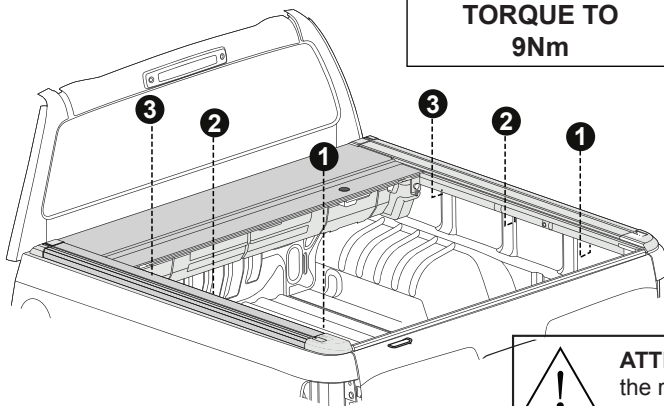
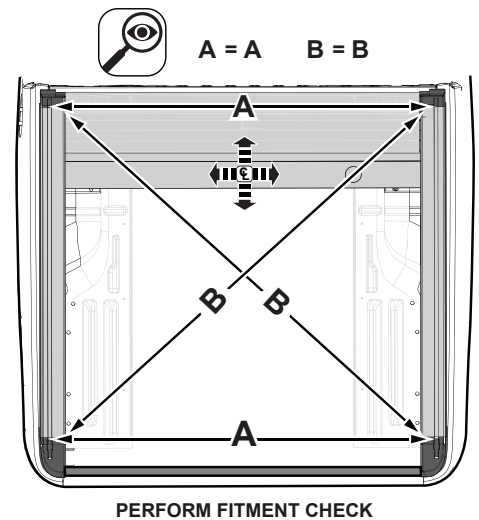
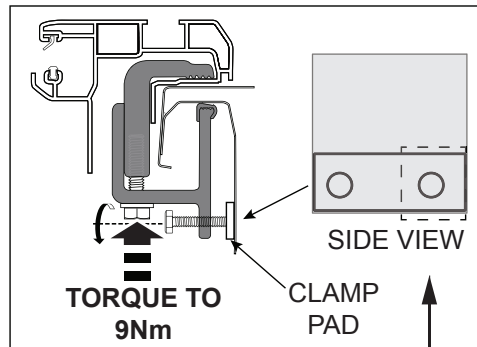
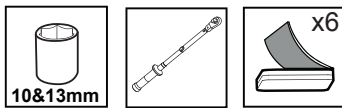

ATTENTION: The side M6 bolts should be tightened until it contacts with the rectangular clamp pad. The bolts should not be tightened any further.

7 Torque (9Nm) the rear set of cover clamp bolts, ensuring cover does not move after tightening. Perform diagonal fitment check (bolts may need loosening for adjustment). At this stage the clamp bolts should be tightened from tailgate to the cab to 9Nm.

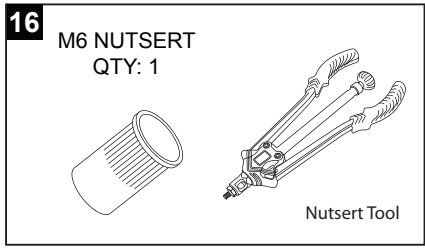
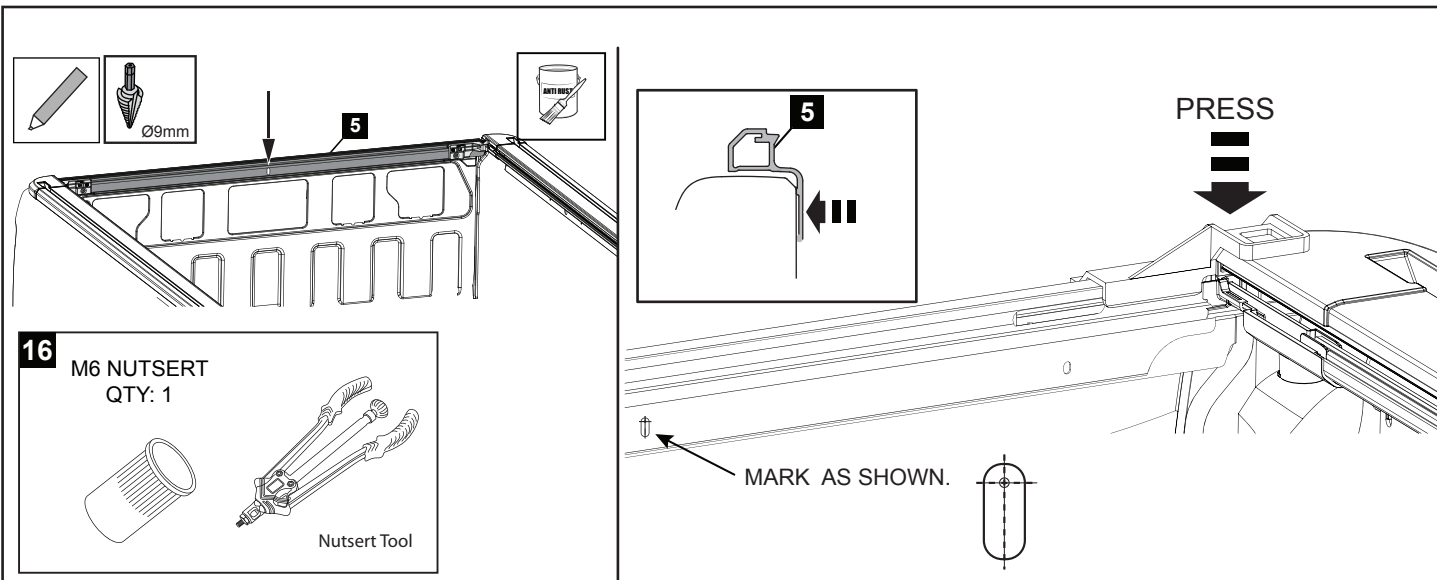

8 Ensure the Tailgate Rail (5) is pushed down and flush with the tailgate. Mark and centre punch the centre slot as shown. Remove tailgate rail and jigs. Drill marked location with 9mm Step Drill. Apply rust inhibitor to the hole in the tailgate. Using Nutsert tool fit 1 Nutserts to the tailgate.

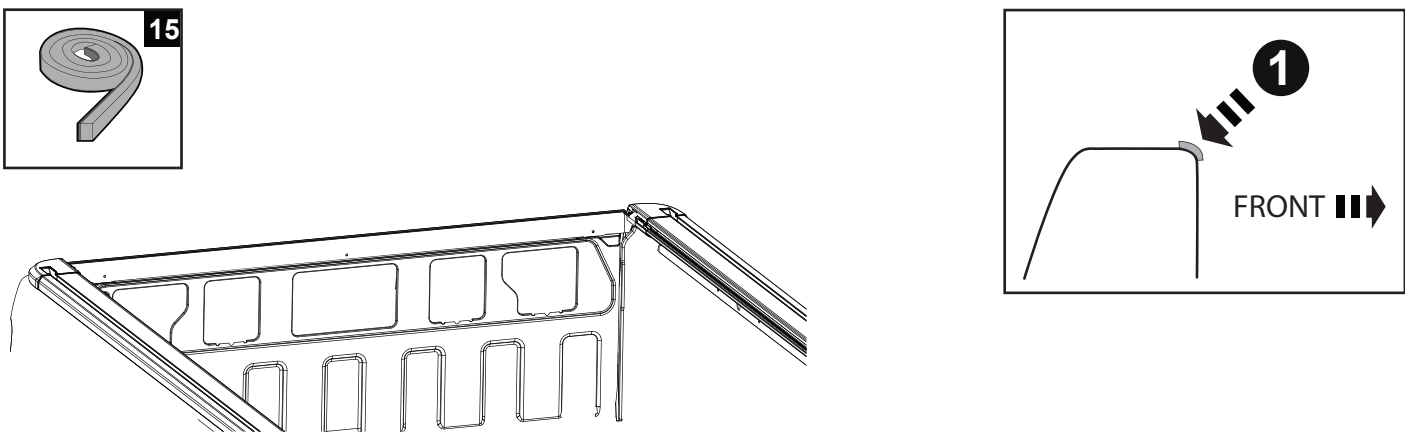

9 Clean tailgate with isopropyl alcohol (50/50), apply primer and let dry. Apply foam tape (15) to the tailgate inside top edge as shown in detail.

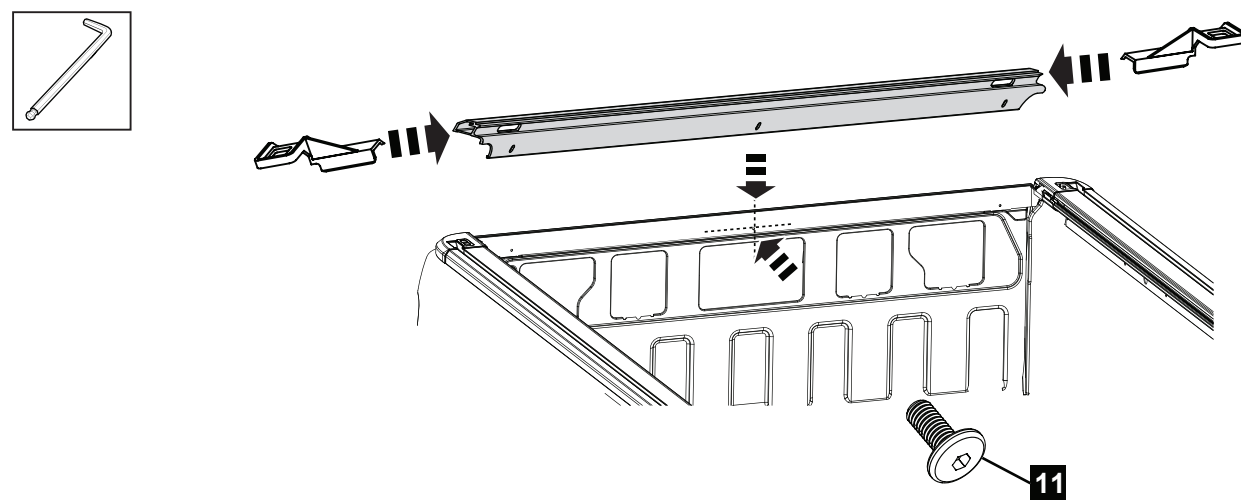

10 Refit the tailgate rail with the jigs to the tailgate. Push down hard in the centre above the bolt fixing onto the tailgate rail and secure with the centre bolt as shown. Torque to 5.5Nm. Remove the jigs.

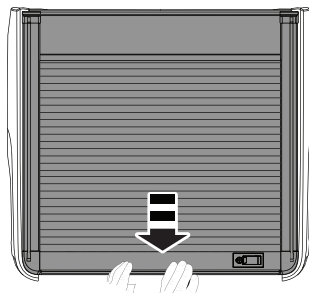
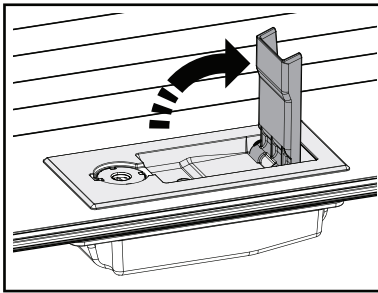
1

NOTE: LIFT HANDLE TO DISENGAGE BRAKE AND MOVE THE ROLLTRAC TO CHECK IF IT IS ROLLING FREELY

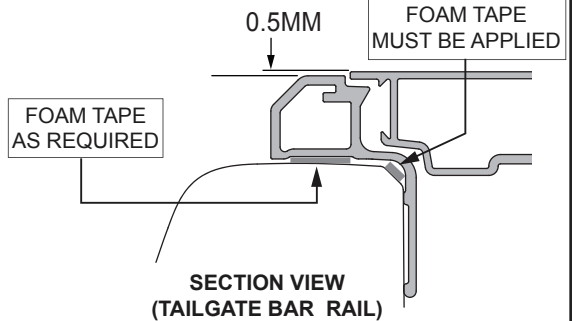
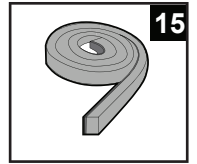
2

11 Pull the EGR RollTrac rearward to check it is rolling freely and the alignment is 0.5mm above the tailgate rail as shown in detail. **NOTE: At this stage tape may need to be applied to the tailgate rail in order to lift the tailgate rail to the 0.5mm level as required.**

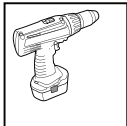
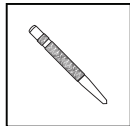

Ø 9mm

16

M6 NUTSERT
QTY: 2

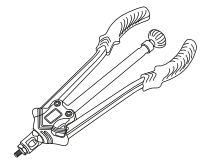
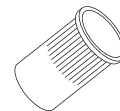

Nutsert Tool

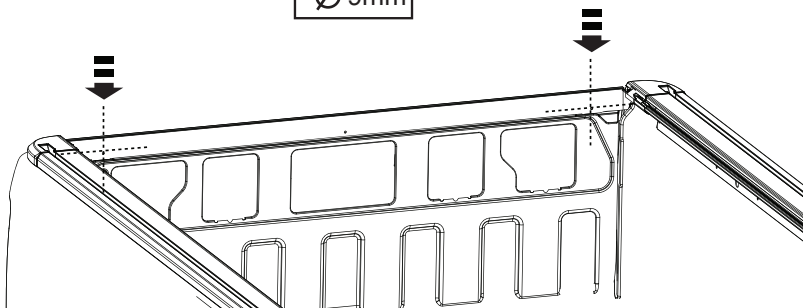

MARK THE CENTRE OF THE SLOT AS SHOWN ON THE 2 OUTSIDE HOLES

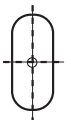

12 Mark the two outside slot holes. Remove the tailgate rail. Centre punch and drill the 2 marked slot positions with 9mm Step Drill. Apply rust inhibitor to the holes in the tailgate. Using Nutsert tool fit 2 Nutserts to the tailgate.

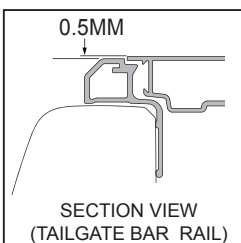
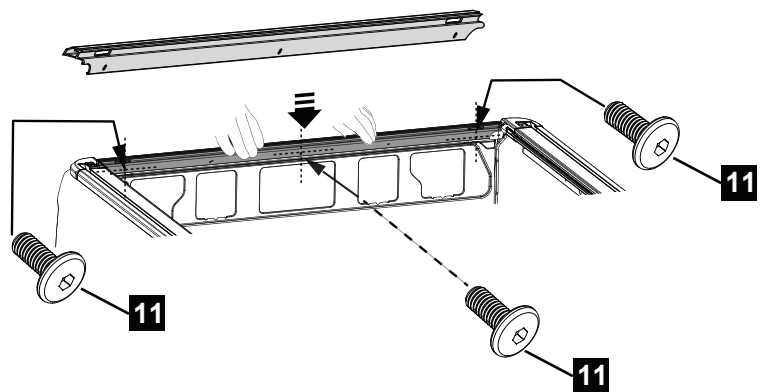
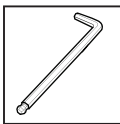

13 Fit tailgate rail, push down to previous position and tighten with 3 M6 screws (11). Check 0.5mm alignment prior to torquing the screws to 5.5Nm.

FIT FRONT DRAIN TUBES TO THE CANISTER

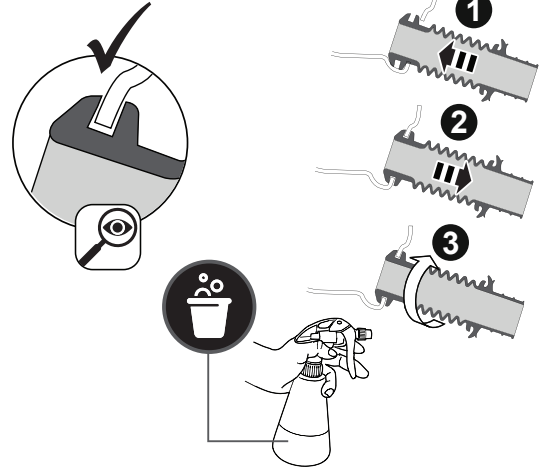
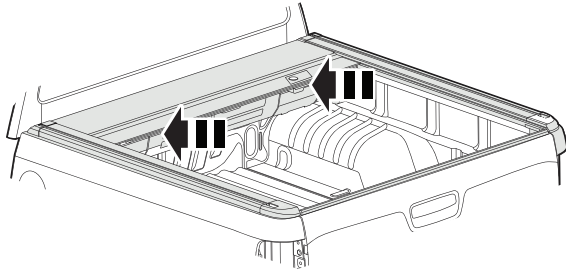

INSTALL REAR DRAIN TUBES TO TUB

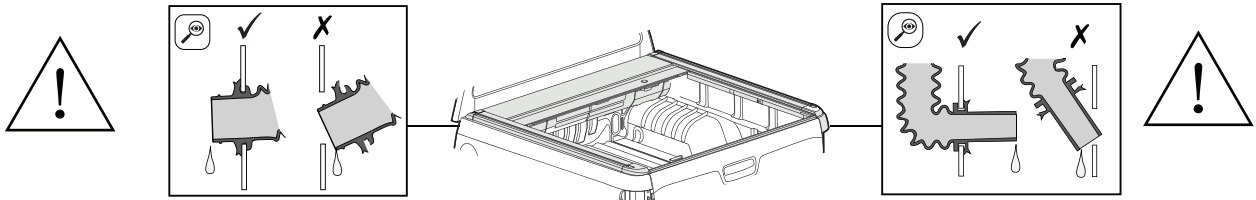
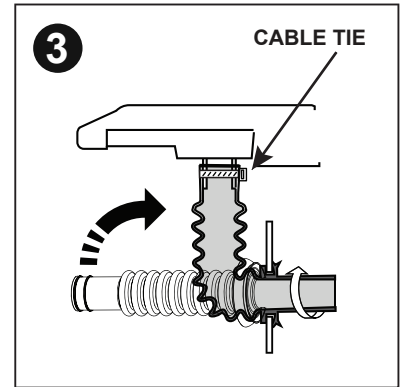
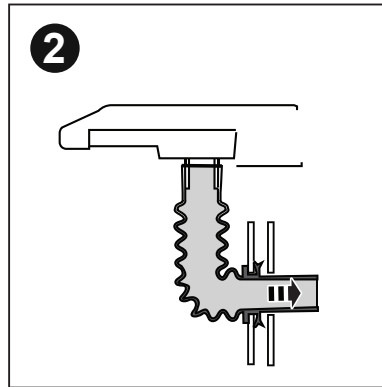
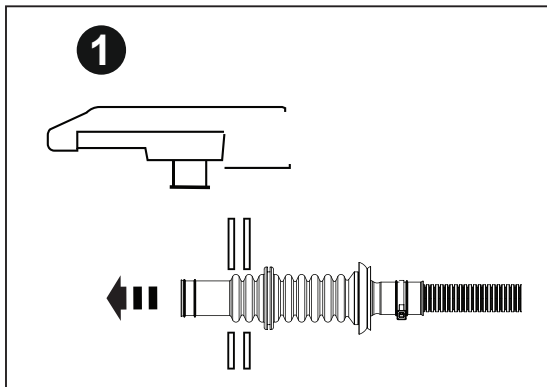

14 Connect the front drain tubes (13) to the canister cover. Connect rear (14) drain tubes to the vehicle tub, making sure that both tubes engage over the wall of the tub. Leakage will occur if they are not properly installed.

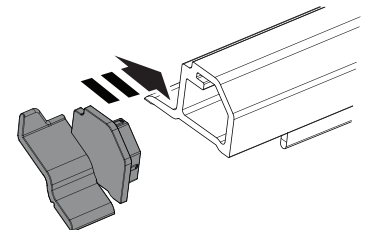
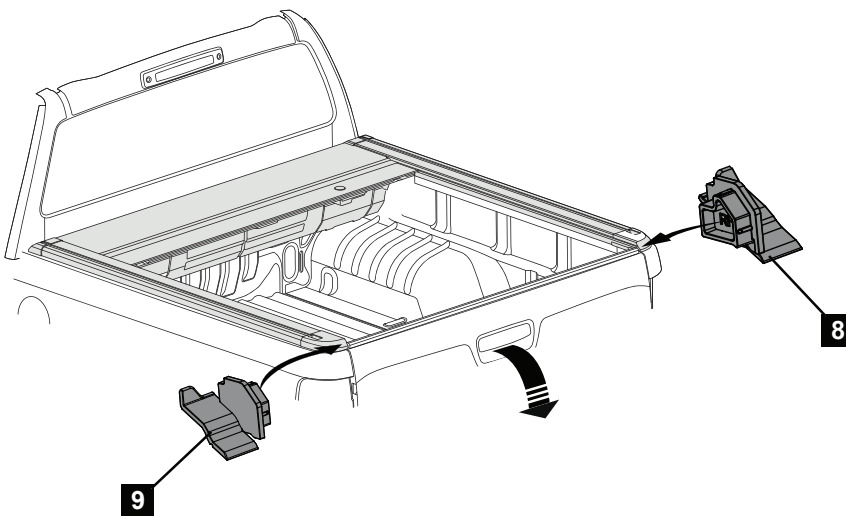

LHS SHOWN RHS IS A MIRROR IMAGE

15 Open the tailgate and install the LHS (9) and RHS (8) Wiper Seals into the Tailgate Rail (3).

SILICONE LUBRICATION TO THE SPIRALS (MODELS MAY VARY, IMAGES FOR REFERENCE ONLY)

- 1** Open tailgate and EGR RollTrac

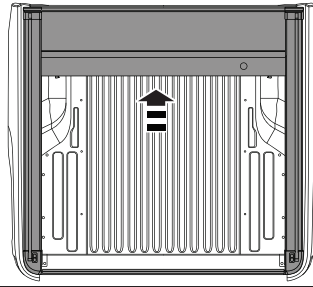
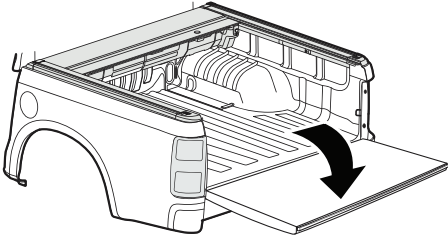

TOOLS REQUIRED:

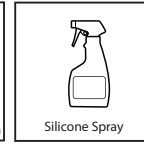
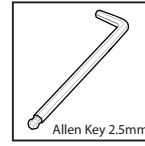

- 2** Using a 2.5mm Allen Key remove the 4 screws and open the inspection covers.
WARNING: Keep clear of moving parts and avoid unnecessary operation of the EGR RollTrac while inspection covers are open.

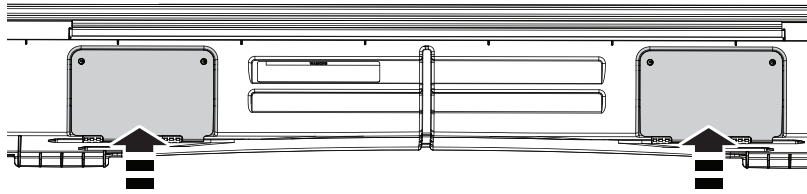

INSPECTION COVER

INSPECTION COVER

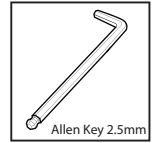

- 3** Close the EGR RollTrac to access canister internals

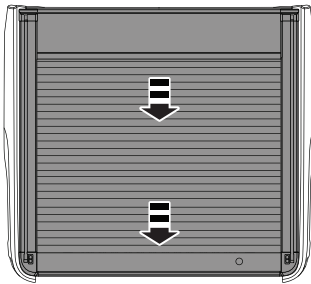

- 4** To avoid water leaks, look into the inspection points and check that the flanges of both front drain tubes are correctly engaged to the canister cover (without any kinking etc.), readjust if required.

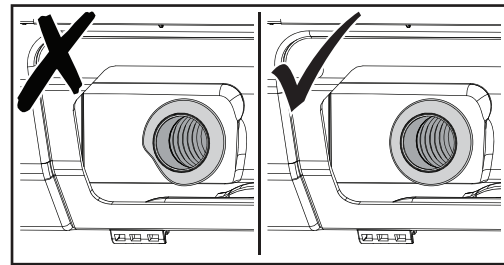

- 5** Using plastic compatible 100% Silicone Spray (ONLY) spray onto the spirals on both ends of the canister through the inspection points.

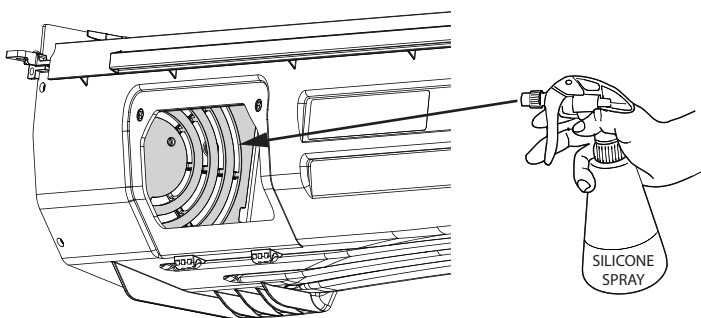

- 6** Open the EGR RollTrac

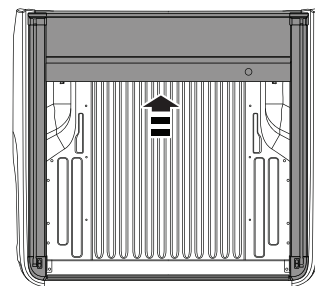

- 7** Close the inspection covers and secure with retained screws. Open and close the EGR RollTrac to distribute lubricant and check operation.

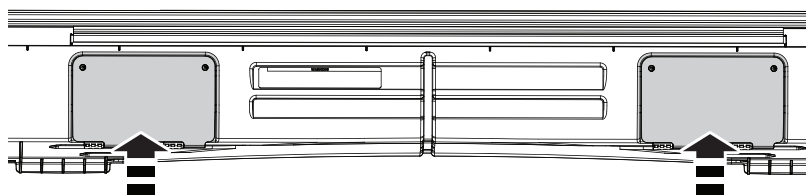

INSPECTION COVER

INSPECTION COVER

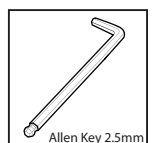

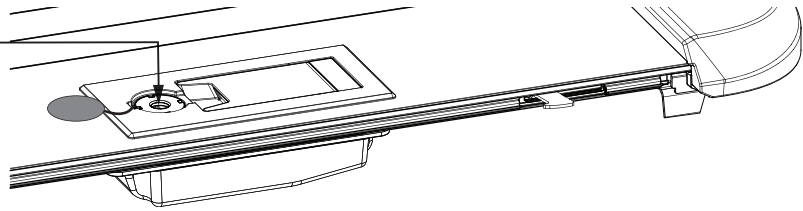
Locking / unlocking using key:

1. Ensure the EGR RollTrac handle is down.
2. Open the rubber cap covering the lock and using the provided key turn LEFT (CCW) to lock and RIGHT (CW) to unlock the hand rail.
3. Check latch engagement by opening the tailgate, if lock does not engage recheck EGR RollTrac installation. Ensure the lock cap is pushed down to seal the lock.

Note: handle must be folded down prior to locking / unlocking with key. Ensure the lock cap is pushed down to seal the lock after every use.

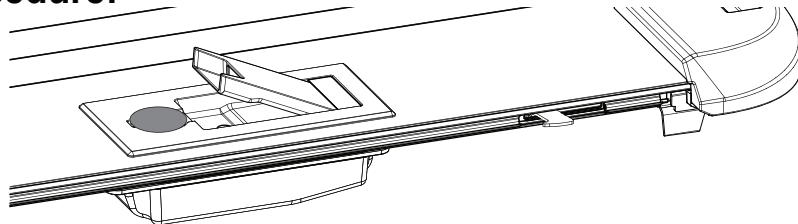
Opening & Closing Procedure:

Ensure the EGR RollTrac is unlocked. Lift the handle approx 30 degree up, in order to release the latches from the tailgate rail and open the vehicle tailgate.

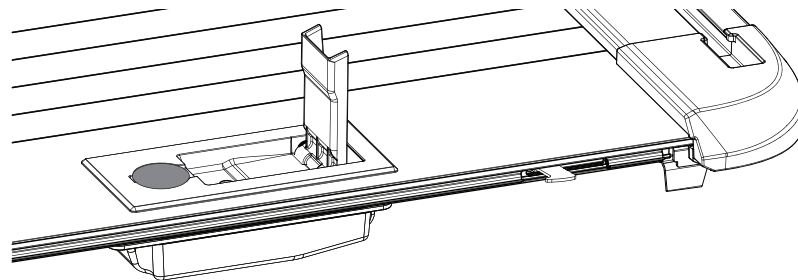

Lift the handle up to 90 degree, in order to disengage brake and slide the hand rail.

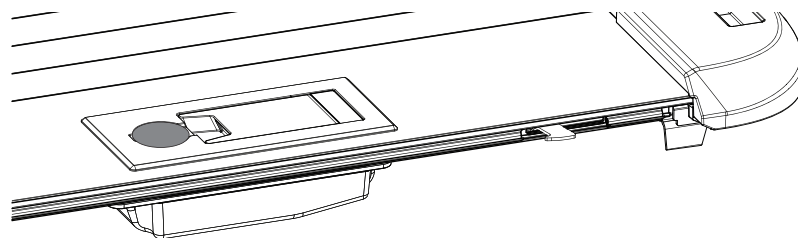

Set the hand rail to desired position and fold the handle down.

NOTE: Cover should open and close smoothly. If cover does not lock or open correctly, please refer to the trouble shooting section in the Owners Manual.

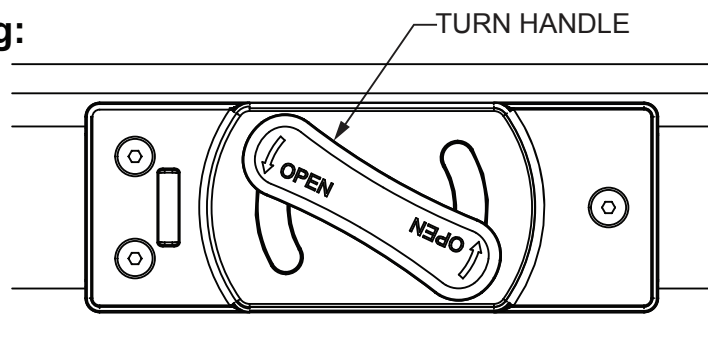
Emergency Opening:

Turn the emergency release handle located on the centre of the hand rail assembly and retract the EGR RollTrac.

FINAL NOTES

Dispose of all packaging and waste according to local regulations.
Retain your Owners Manual, Fitting Instructions and fitting jigs for future reference.
Refer to Owners Manual for operation, warranty, service and product care guidelines.
Complete the installation check list in Owners Manual and store keys safely.
Clean the EGR RollTrac using multi purpose cleaner to remove any residue from packaging and installation.