

SOFT TONNEAU COVER FITTING INSTRUCTIONS

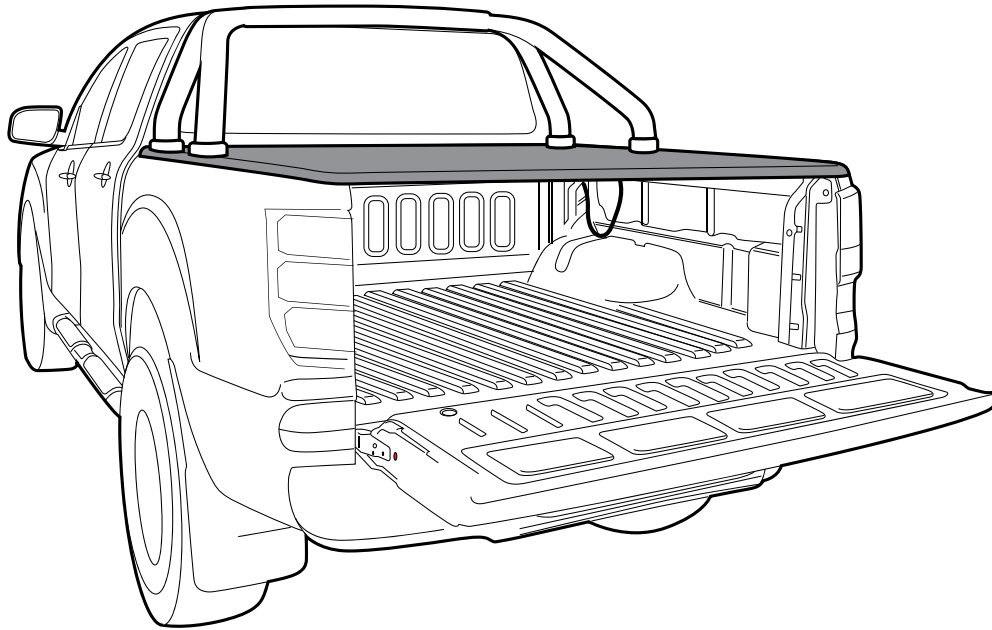

Care Instructions:



Clean Tonneau Cover with a mild detergent and water solution.

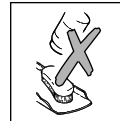

Do not use abrasive cleaners or solvents.

PLACE THESE INSTRUCTIONS IN VEHICLE'S GLOVE BOX AFTER INSTALLATION IS COMPLETE.

IMPORTANT

WARNING!

Securely lock Tonneau Cover or Draw Back and Securely Tie Back before operating vehicle! Failure to do so could result in unexpected opening of the Tonneau Cover from sudden wind gusts, which could cause damage to the vehicle and/or your Tonneau Cover!

MAINTENANCE

Your Tonneau Cover only requires periodic cleaning with water, neutral car wash soap and sponge or flannel. Never use any chemicals or abrasive products to clean your Tonneau Cover. Always use the Central Crossbars to give support and facilitate water drainage. The latch mechanisms only require occasional lubrication with Graphite Powder. Using alternative lubricants or oils, will void warranty. All installation Clamps must be regularly checked and tightened if required.

IMPORTANT!

Read instructions carefully before installation. It is strongly recommended that installation is conducted by an authorized dealer.

- This product must be installed exactly as specified in these instructions. Failure to do so may result in improper fit and/or retention.
- Do not stand/sit or rest heavy objects on Tonneau Cover.
- Do not carry Sharp or Pointed Material, or Material that exceeds Bed Height with Tonneau Cover closed.
- Humans or animals are not to be under the closed Tonneau Cover at any time.
- Securely lock Tonneau Cover before operating vehicle.
- Do not carry open volatile chemicals with Tonneau Cover installed.
- If contact with volatile chemicals occurs clean Tonneau Cover with mild detergent and water solution.
- This product is water resistant, but may not be fully waterproof.

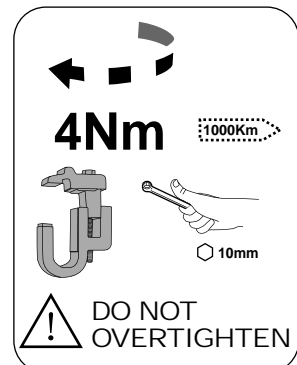
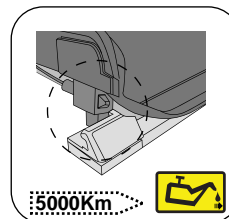

COMPONENTS LIST

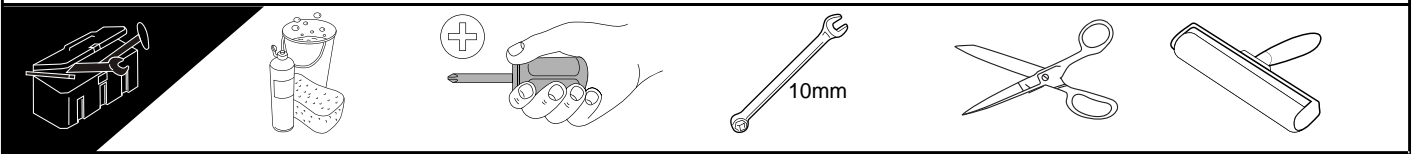
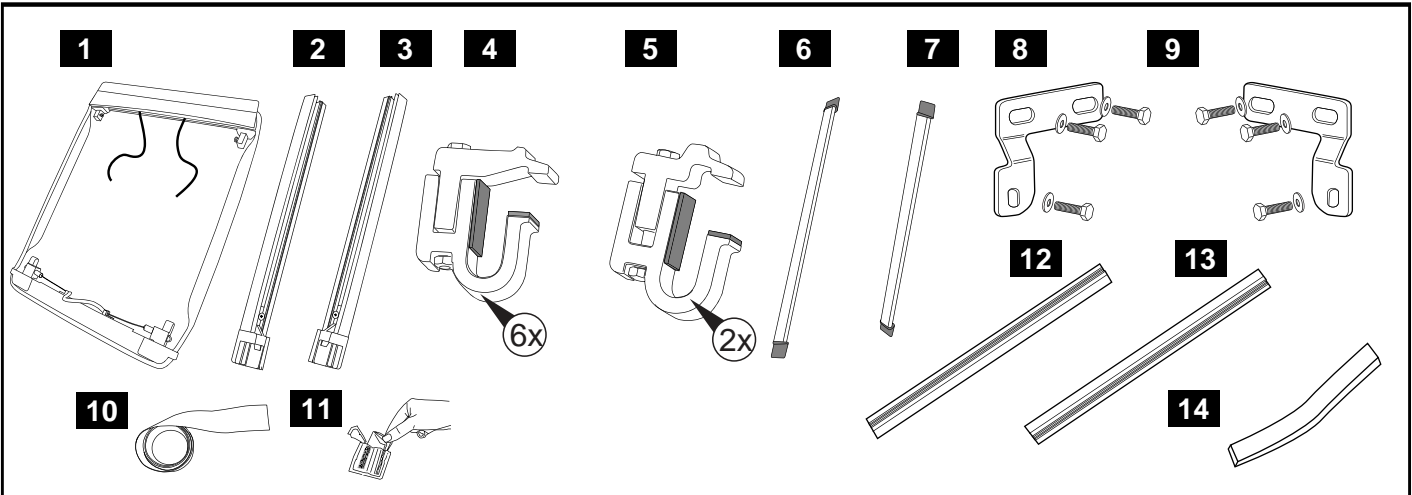

No.	PART NAME	QTY.
1	Front Rail, Cover, Corner Assembly	1
2	Side Rail LH Rear	1
3	Side Rail RH Rear	1
4	Front Side Clamp (Long Arm)	6
5	Rear Side Clamp (Short Arm)	2
6	Front Support Rail	1
7	Rear Support Rail	1
8	Front Rail Tab Clamps LH and M6 Bolts	1
9	Front Rail Tab Clamps RH and M6 Bolts	1
10	Paint Protection Tape	1
11	Alcohol Wipes	2
12	Side Rail LH Front	1
13	Side Rail RH Front	1
14	EPDM Seal	1

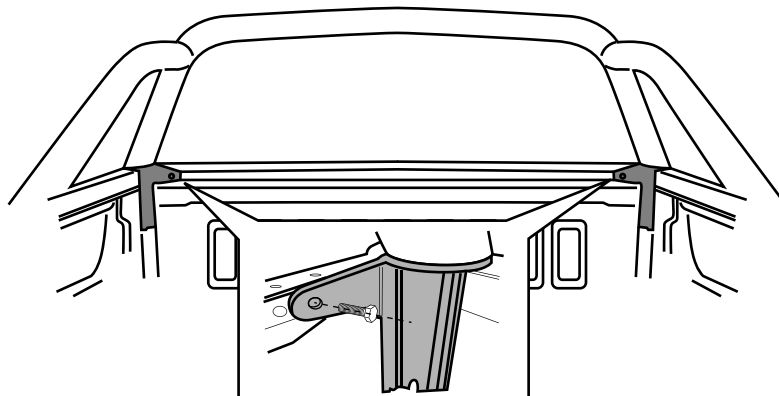

1. Remove the existing sportsbar bracket front screw (2 off). Note: Do not remove the sportsbar bracket screws on the sides.

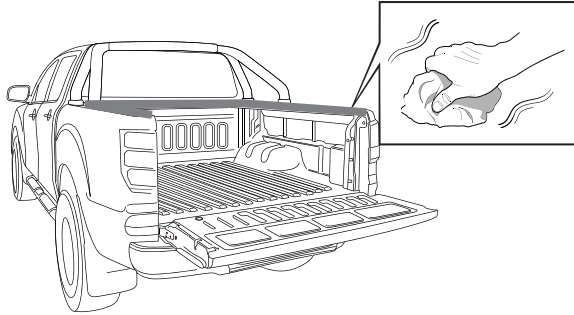
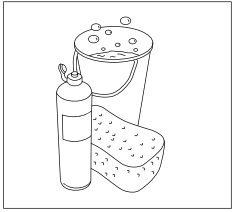

1 OPEN REAR TAILGATE
CLEAN AND DRY
INSTALLATION AREAS

2. Open the rear tail gate. Thoroughly clean and dry the installations areas.

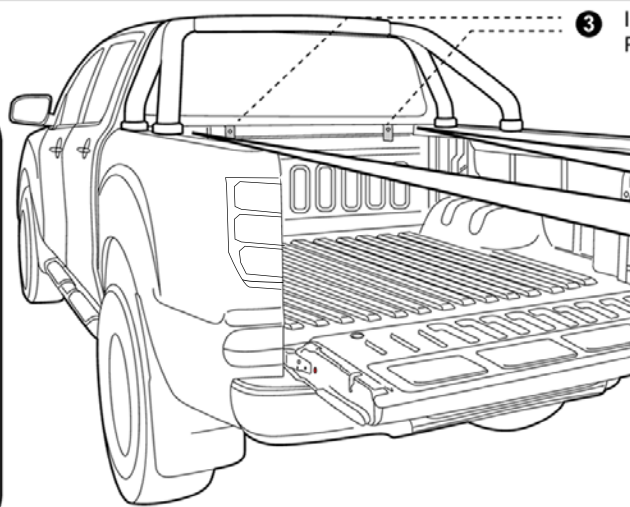
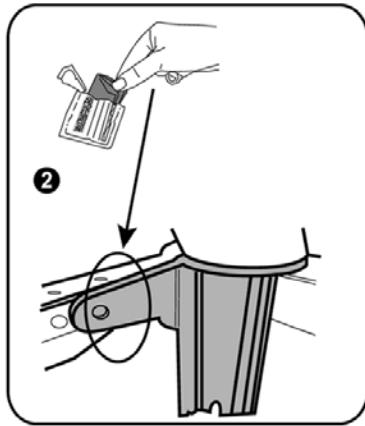

3 INSTALL 2 OFF PAINT
PROTECTION TAPE

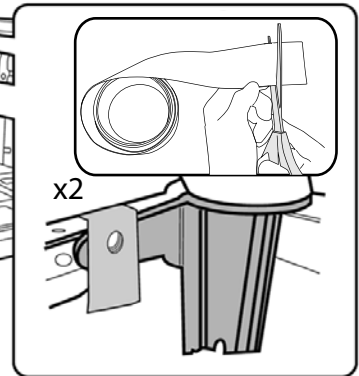

3. Cut out 2 sections (each of width 30 mm) of paint protection tape from the roll. Make a clearance hole in the 2 tapes. Clean the tub/ sportsbar bracket area with alcohol wipes, align the holes in the paint protection tape with holes in the sportsbar bracket as shown in diagram above and apply tape.

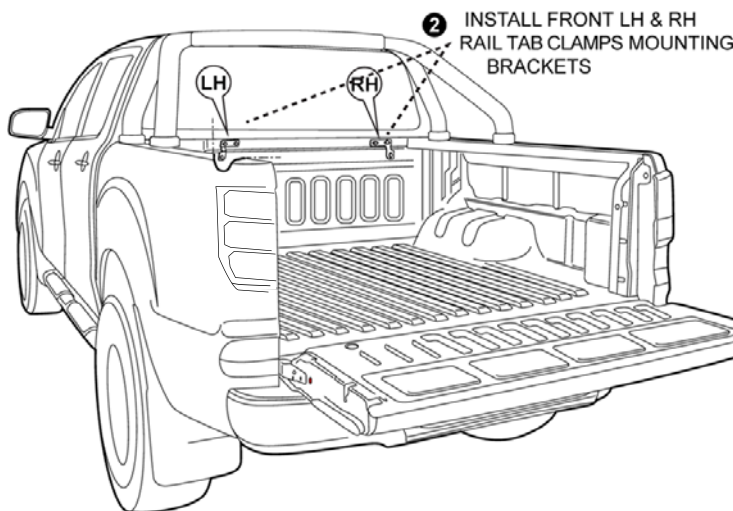

2 INSTALL FRONT LH & RH
RAIL TAB CLAMPS MOUNTING
BRACKETS

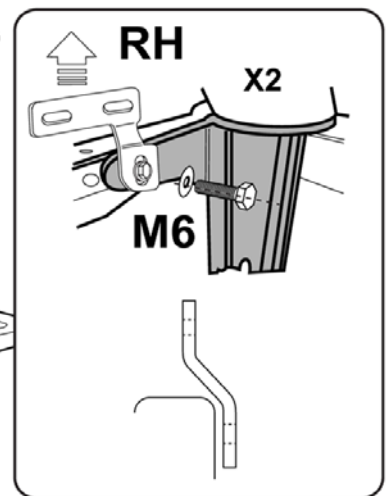

4. Install front rail tab clamps mounting brackets LH & RH into existing holes in sportsbar bracket / tub using M6 screws and washers provided. Do not tighten fully.

Note: Top bend area of clamps to be towards front of the vehicle.

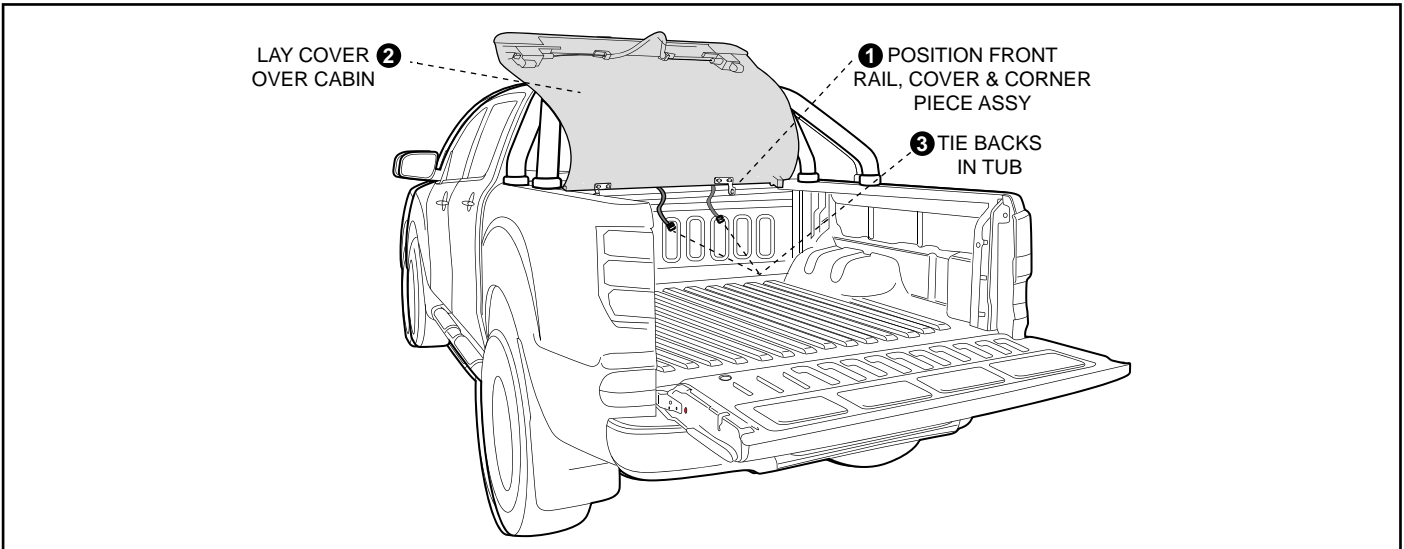

5. Position the front rail at the front of the tub. Carefully lay the cover over the vehicle cabin. Ensure tie backs are in the tub.

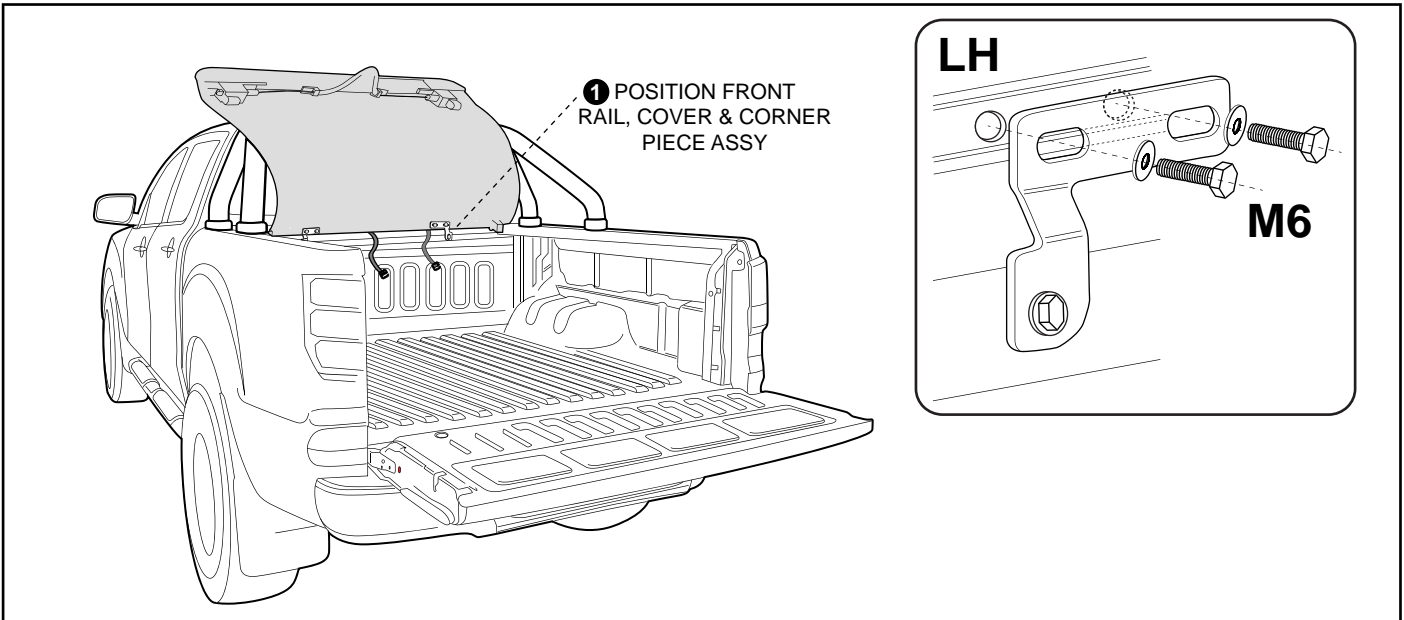

6. Align the threaded inserts in the front Soft Tonneau Cover Rail with the top holes of the Front Rail Tab Clamps and insert M6 Bolts and Washers and hand tighten.

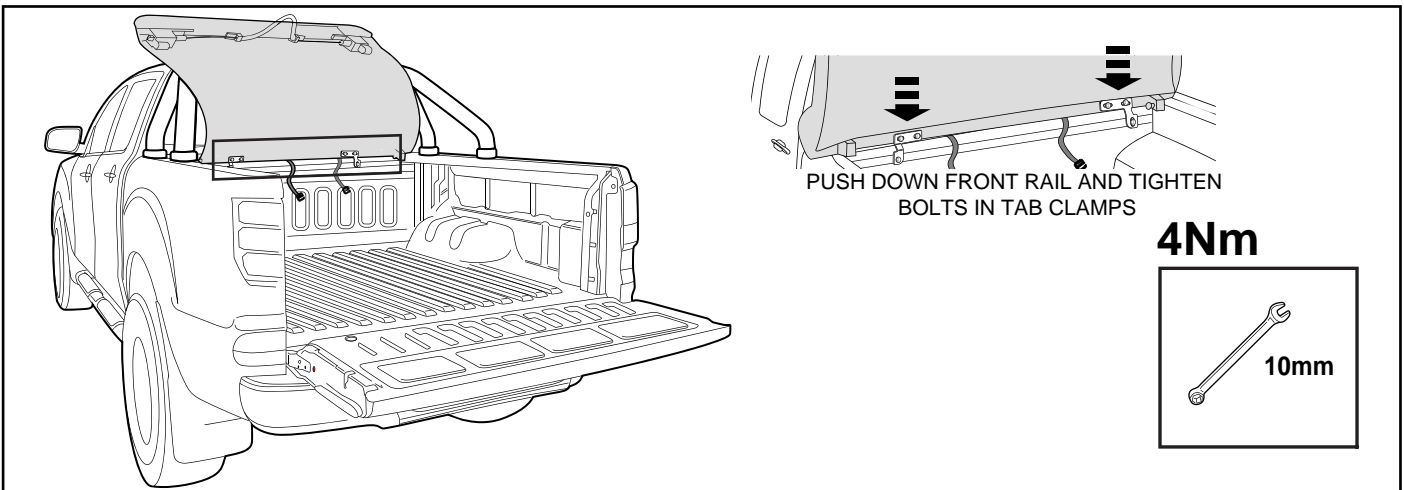

7. Align the Tonneau with the sports bar front legs, push down the front rail and tighten bolts in tab clamps.

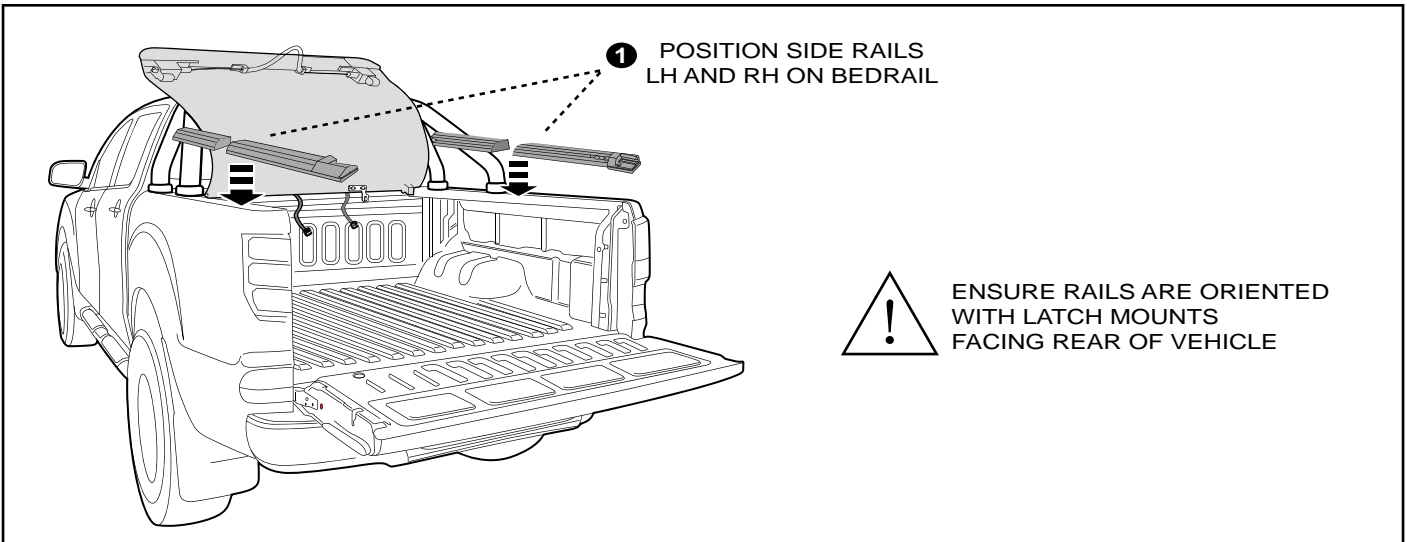

8. Position Side Rails on the tub sides ensuring latch mounts are orientated to the rear of the vehicle.

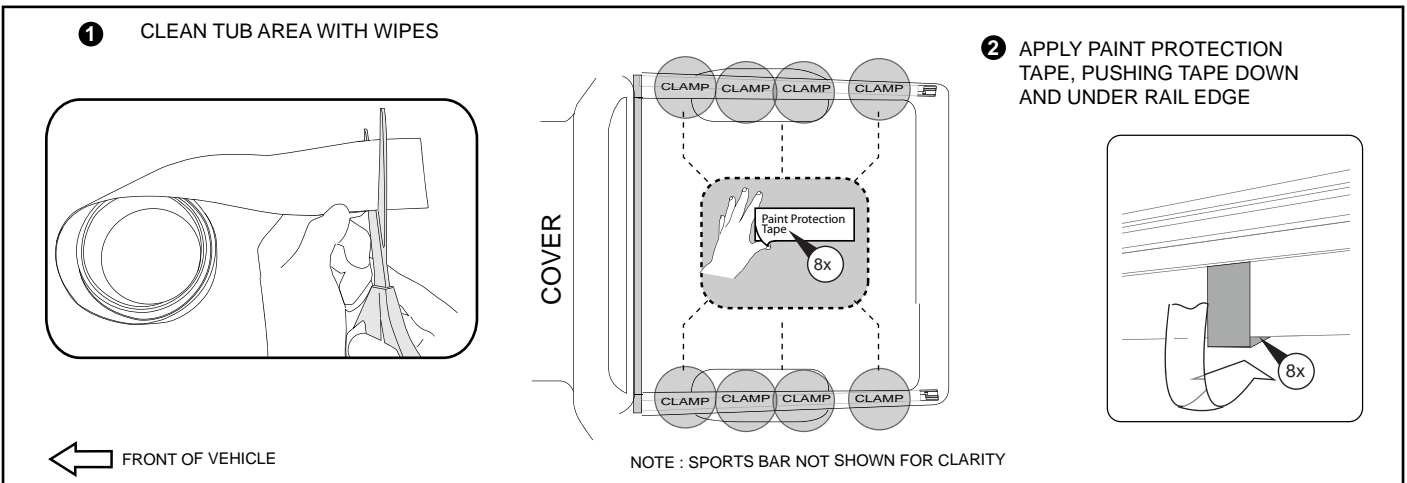

9. Clean the tub areas with alcohol wipes in the location marked 'CLAMP' on the side rails. Cut out 8 sections (each of width 30 mm) of Protection Tape from the roll and apply it on the tub in the location marked 'CLAMP' on side rail.

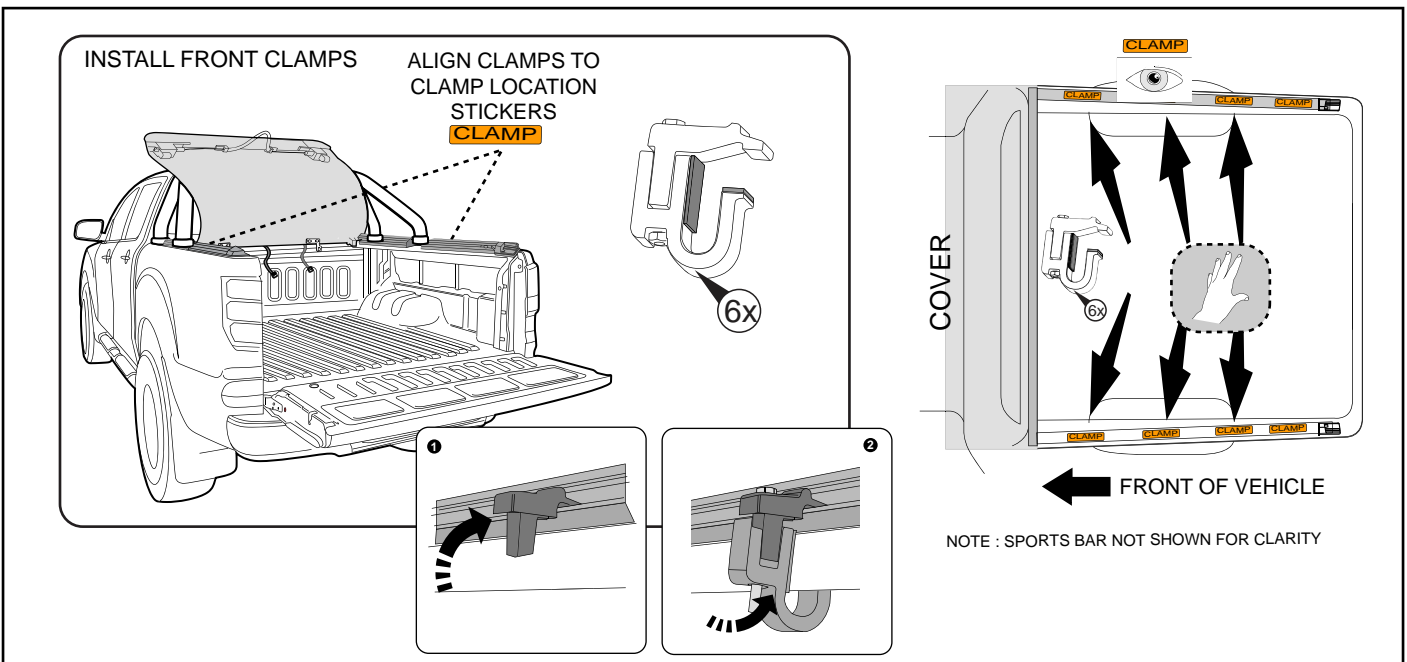

10. Using the clamp location stickers on the side rails, mount front clamps to the tub body ensuring that the side rails are flush with the outside of the tub body.

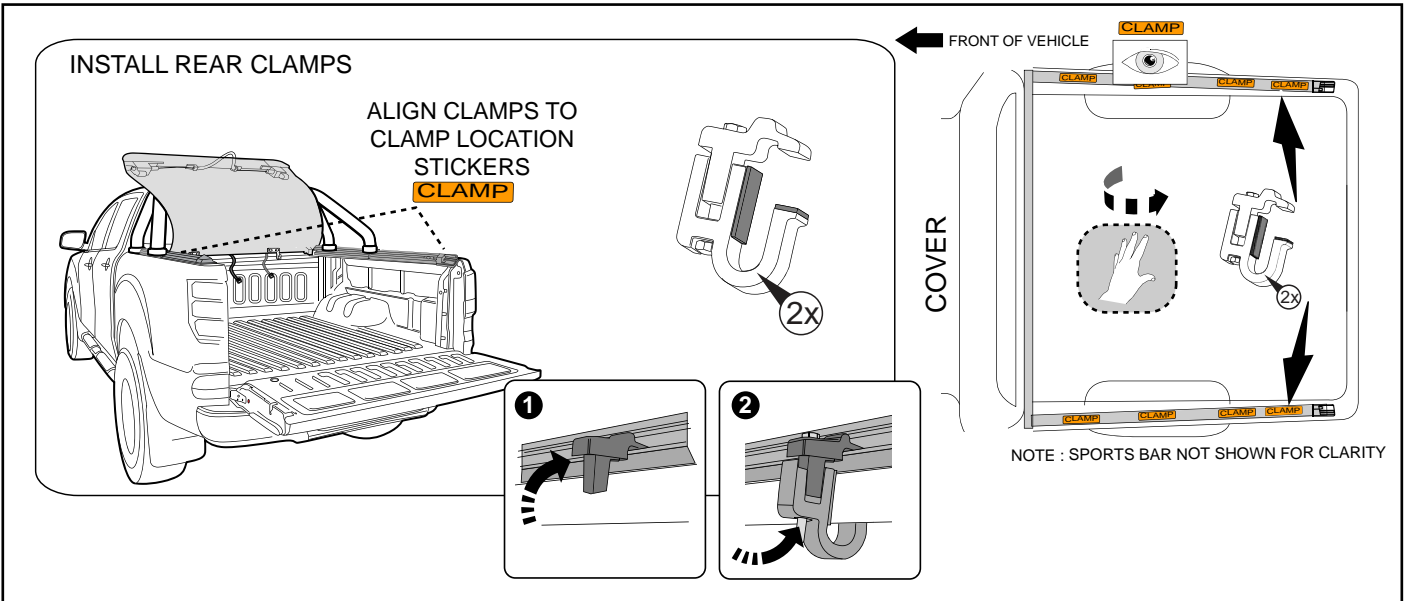

11. Repeat process and install Rear clamps the side rails and tub ensuring that the side rails are flush with the outside of the tub body.

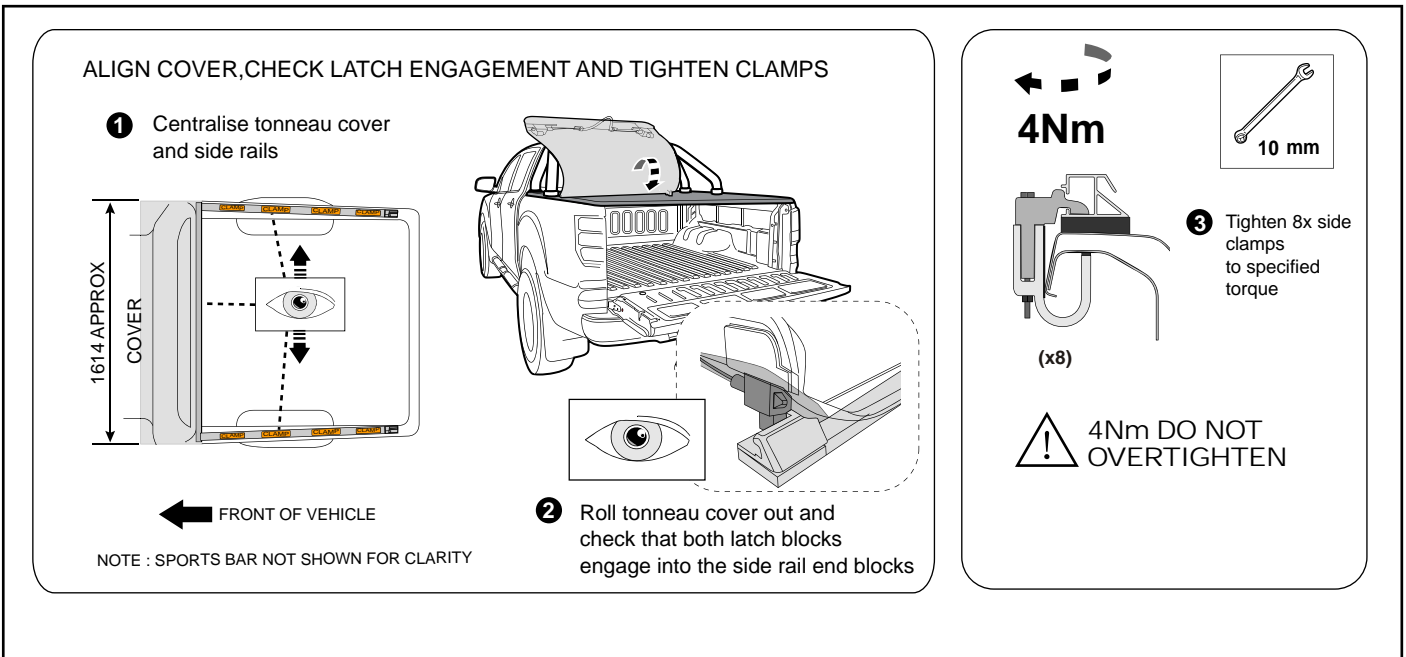

12. Centralise and align tonneau cover and rails. Check position of side rails by rolling tonneau cover out and ensuring that side latched engage into side rail end blocks on the rear of tonneau cover. The tension of the tonneau is controlled by the positioning of the side rails. If the tonneau is too tight length wise, it may create gap in the tailgate area which can be controlled by moving the rear side rail forward and releasing the tension. When correctly aligned lay cover back on the vehicle roof and tighten side clamps to the torque specified.

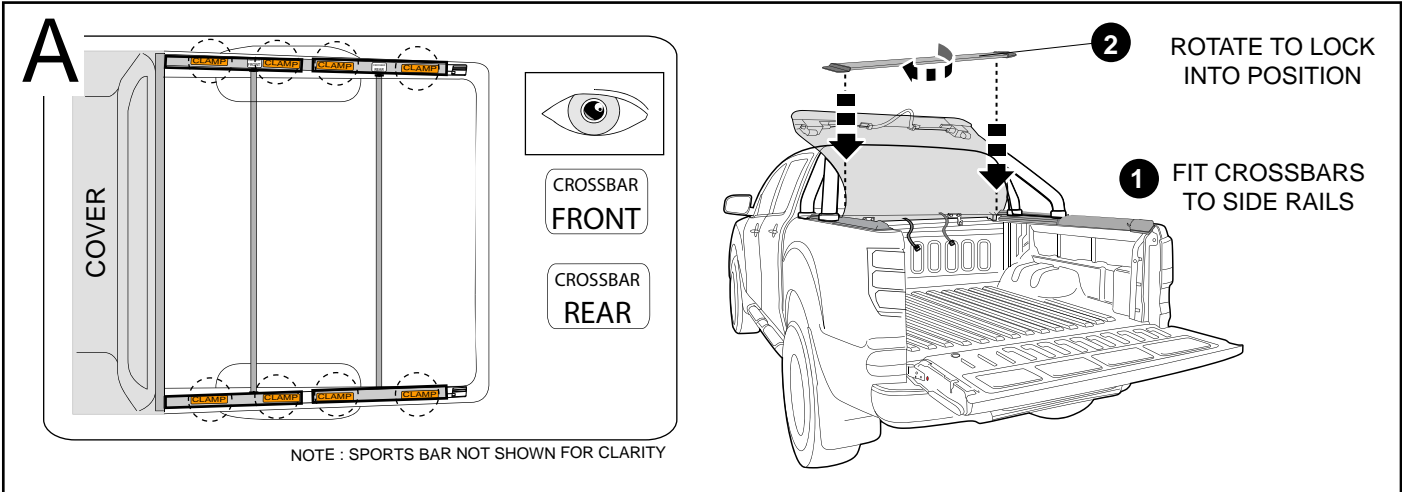

13. Fit the Cross Bar marked 'Front' closest to the Cabin & the Cross Bar marked 'Rear' closest to the Tailgate. Refer identification stickers on side rails showing positions.
NOTE: Crossbars must be fitted as instructed to assist Water Drainage. Failure to fit Crossbars may result in Damage and void Warranty.

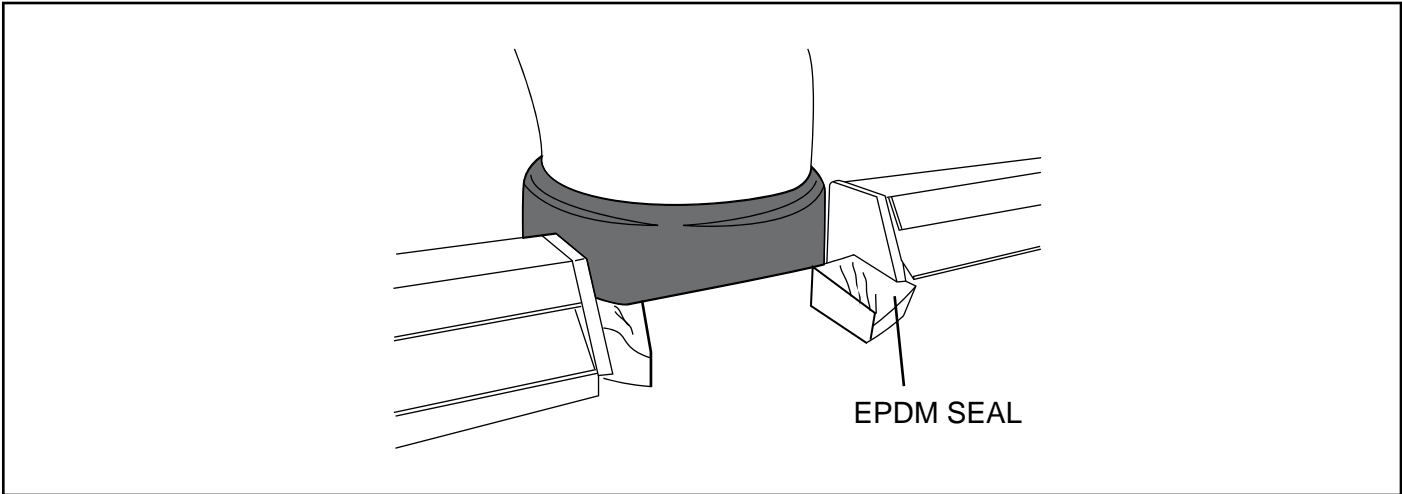

14. Cut the EPDM seal to required length and seal the gaps near the sports bar foot.

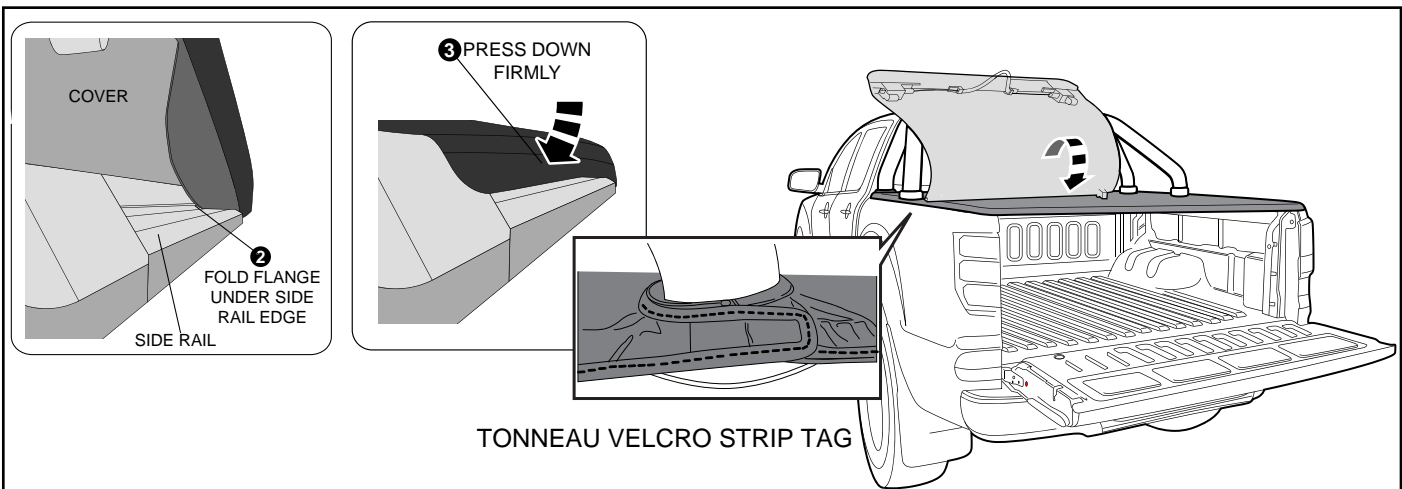

15. Roll cover over tub towards the rear of the vehicle. Fix the cover to the side rails by folding the flexible flanges on the cover outward and rolling them in under the edge of the side rails. To lock them in press firmly on the outside of the cover. Wrap the tonneau velcro strip tag around the sportsbar foot and seal it.

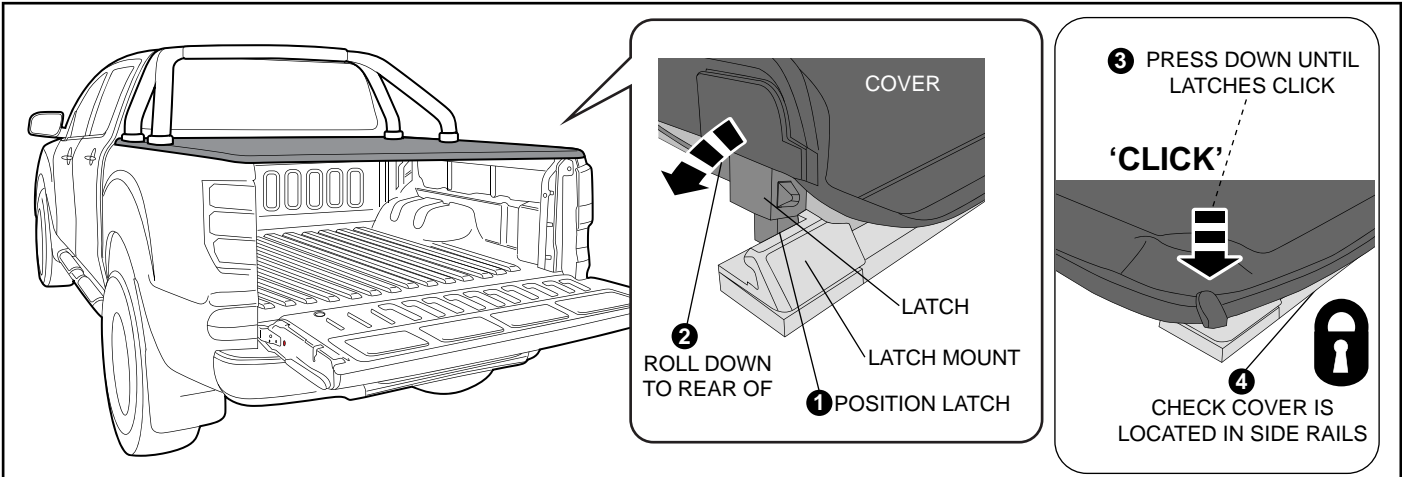

16. Position latches into stretch mounts. Holding the cover rail at the rear, roll towards the rear of the vehicle and down until latches click and are both locked into position. Ensure the flexible side flanges are fully seated into the side rails.

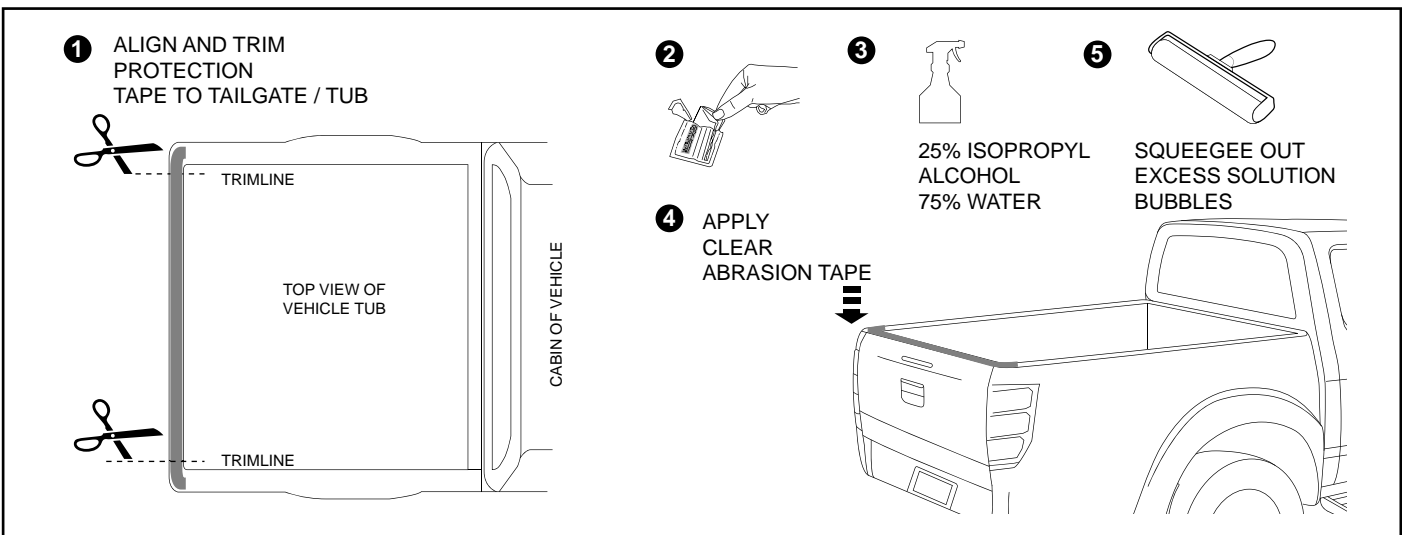

17. Open the tonneau. Align and trim the Paint Protection Tape so that it covers the tub / tailgate area where the tonneau rear rubber seal comes in contact. Clean the area with alcohol wipes. Using a solution of 25% isopropyl alcohol and 75% water in a spray bottle (not supplied) thoroughly spray along the top of tub/tailgate. After removing the liner from the Paint Protection Tape, place it on the tub (The tape wont stick since it is in contact with the solution). Align the tape. When in position use a squeegee to push out the excess solution and bubbles. You may need to squeegee a few times. When finished the tape is virtually invisible.

INSTRUCTIONS TO ROLL BACK SOFT TONNEAU COVER

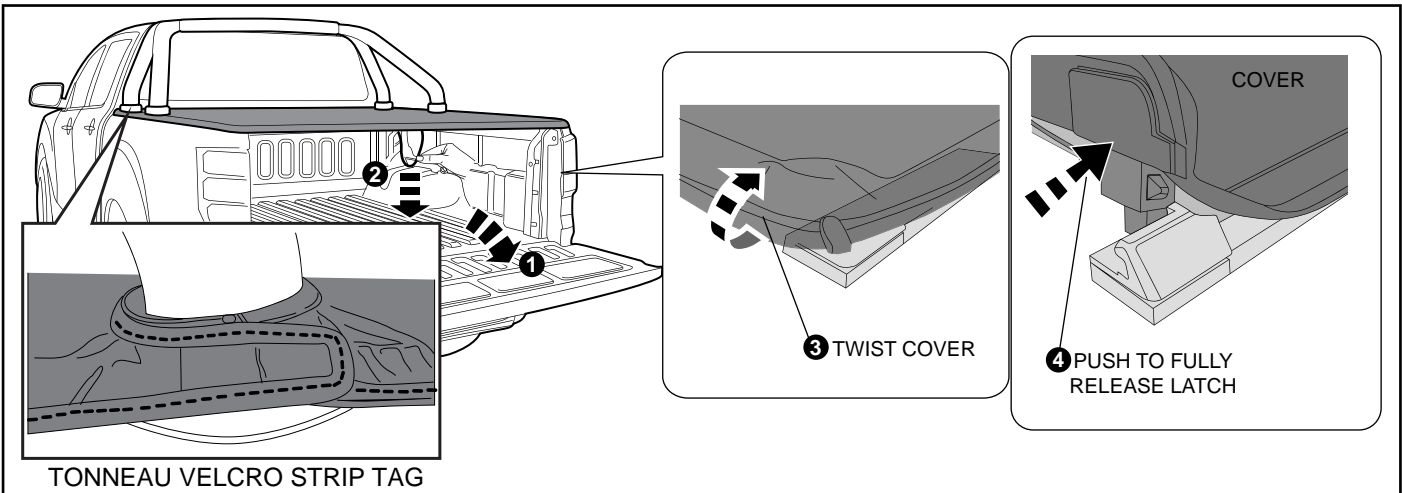

1. Open rear tailgate. Release the tonneau velcro strip tags from the Sports Bar foot. Locate latch release tab under the centre rear of the cover and pull in a downward direction to disengage the latches. Twist the rear rail upward to completely release the latches.

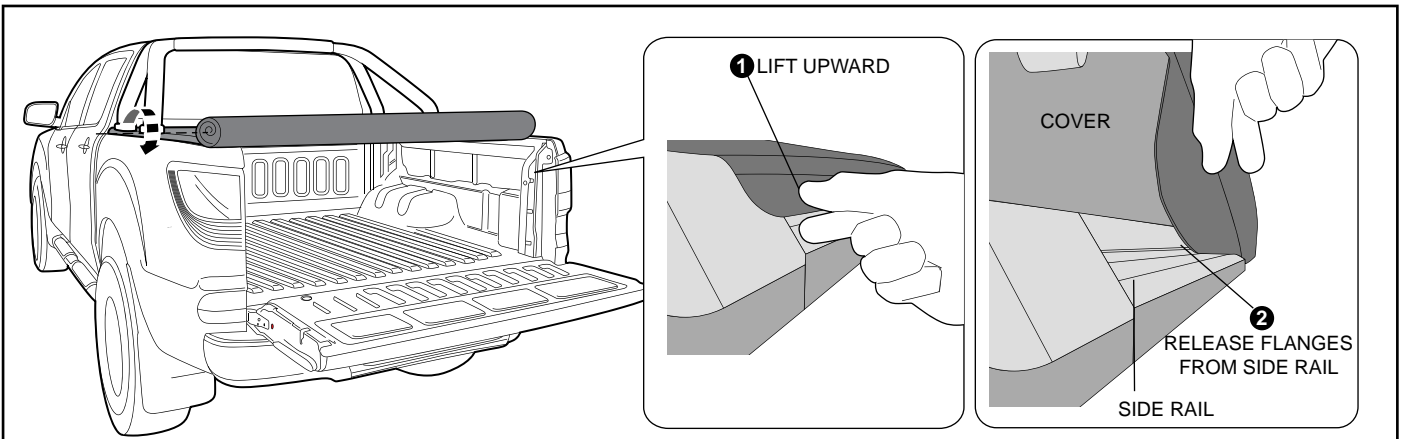

2. Working from the Rear to the Front of the Vehicle, Grip & Lift in an upward direction the Sides of the Cover to Release the Flexible Flanges from the Side rails.
IMPORTANT: Ensure that the flanges are released prior to rolling the tonneau, otherwise they may get damaged.

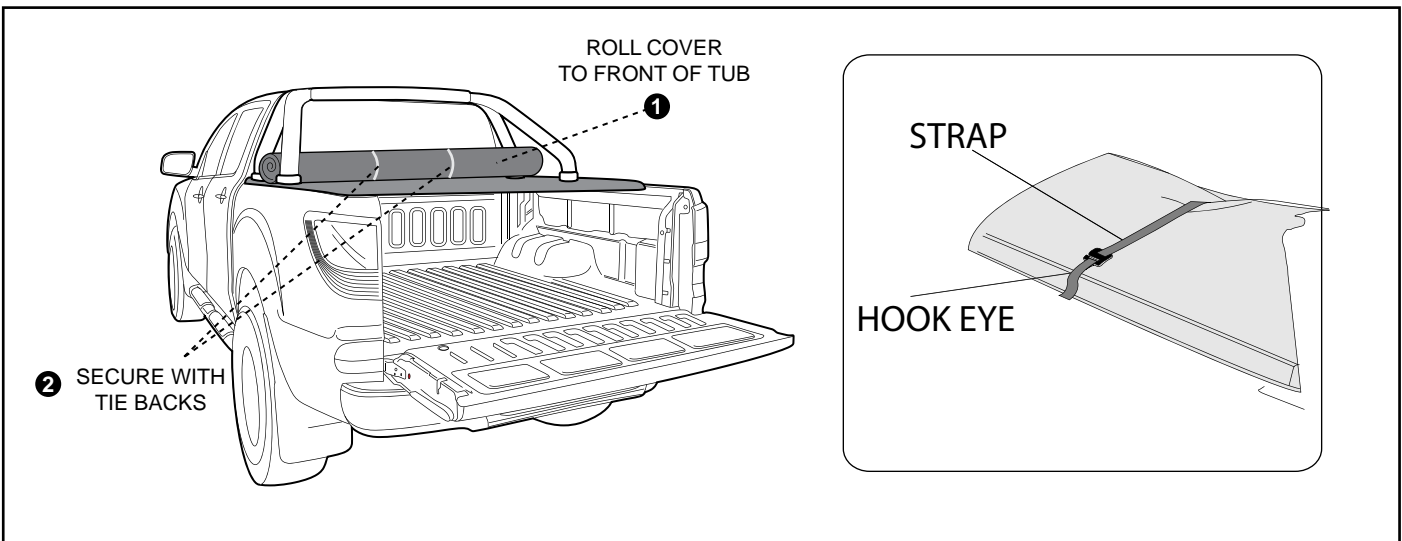

3. Roll the cover to the front of the vehicle and secure with the tie backs.

IMPORTANT

DO NOT CLOSE THE REAR TAILGATE WHEN TONNEAU COVER LATCHES ARE ENGAGED.

When Closing the Vehicle Tailgate Ensure the Tonneau Cover Latches are Dis-engaged First, then close the Tailgate.

Re-engage the Latches and ensure that the entire length of the Cover Side Flexible Flanges are firmly located into the Side Rails as per step 10.

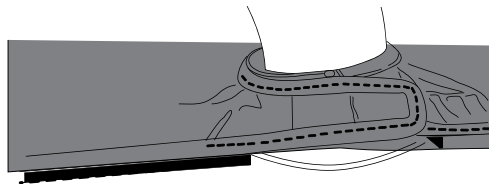
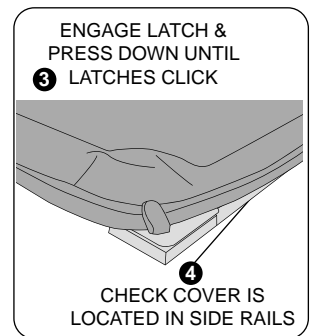
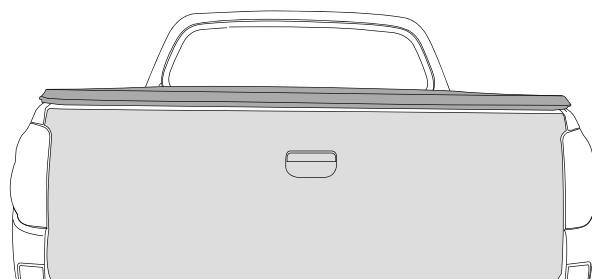
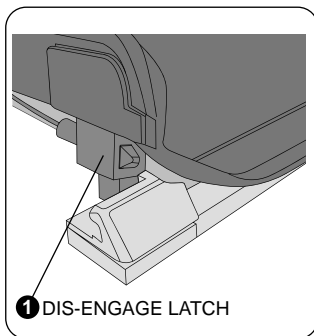

Ensure during installation/removal to gently dis-engage the plastic flange from the side rail prior to pulling the velcro tab across past the rail.

