

SOFT TONNEAU COVER FITTING INSTRUCTIONS

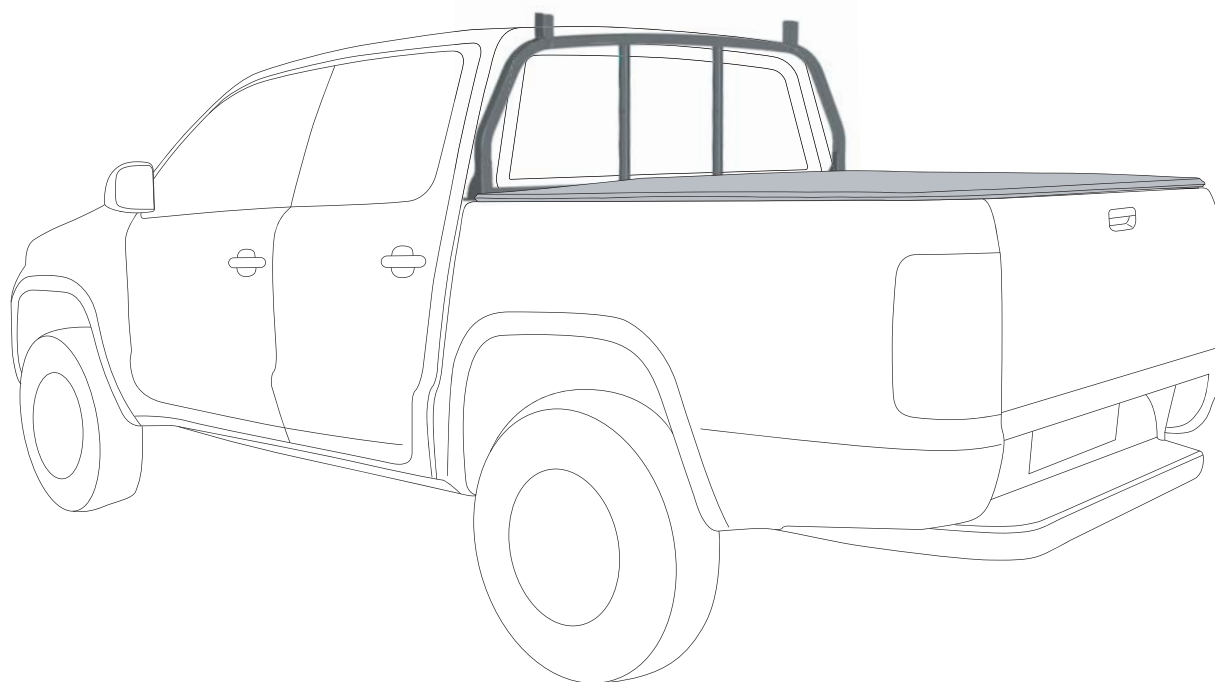

Care Instructions:



Clean Tonneau Cover with a mild detergent and water solution.



Do not use abrasive cleaners or solvents.

PLACE THESE INSTRUCTIONS IN VEHICLE'S GLOVE BOX AFTER INSTALLATION IS COMPLETE.

IMPORTANT

WARNING!

Securely lock Tonneau Cover or Draw Back and Securely Tie Back before operating vehicle! Failure to do so could result in unexpected opening of the Tonneau Cover from sudden wind gusts, which could cause damage to the vehicle and/or your Tonneau Cover!

MAINTENANCE

Your Tonneau Cover only requires periodic cleaning with water, neutral car wash soap and sponge or flannel. Never use any chemicals or abrasive products to clean your Tonneau Cover. Always use the Central Crossbars to give support and facilitate water drainage. The latch mechanisms only require occasional lubrication with Graphite Powder. Using alternative lubricants or oils, will void warranty. All installation Clamps must be regularly checked and tightened if required. Contact area between cabinguard and tonneau front rubber extrusion should be cleared of grit build-up regularly.

IMPORTANT!

Read instructions carefully before installation. It is strongly recommended that installation is conducted by an authorized dealer.

- This product must be installed exactly as specified in these instructions. Failure to do so may result in improper fit and/or retention.
- Do not stand/sit or rest heavy objects on Tonneau Cover.
- Do not carry Sharp or Pointed Material, or Material that exceeds Bed Height with Tonneau Cover closed.
- Humans or animals are not to be under the closed Tonneau Cover at any time.
- Securely lock Tonneau Cover before operating vehicle.
- Do not carry open volatile chemicals with Tonneau Cover installed.
- If contact with volatile chemicals occurs clean Tonneau Cover with mild detergent and water solution.
- This product is water resistant, but may not be fully waterproof.

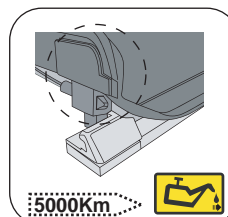

COMPONENTS LIST

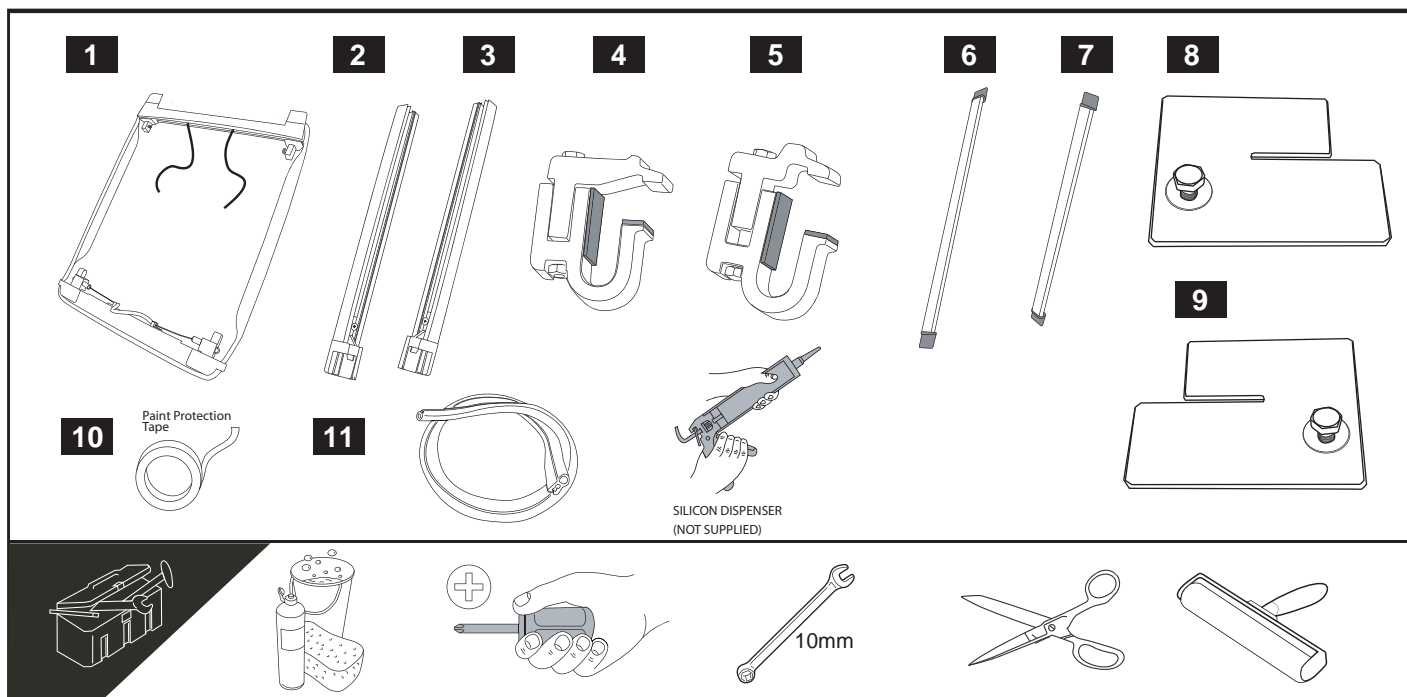

No.	PART NAME	QTY.
1	Front Rail, Cover, Corner Assembly	1
2	Side Rail Assy LH	1
3	Side Rail Assy RH	1
4	Front Side Clamps (Long Arm)	4
5	Rear Side Clamps (Short Arm)	2
6	Front Crossbar	1
7	Rear Crossbar	1
8	Front Bracket LH and M6 Bolts	1
9	Front Bracket RH and M6 Bolts	1
10	Paint Protection Tape 1	1
11	Cabin Guard Seal	1

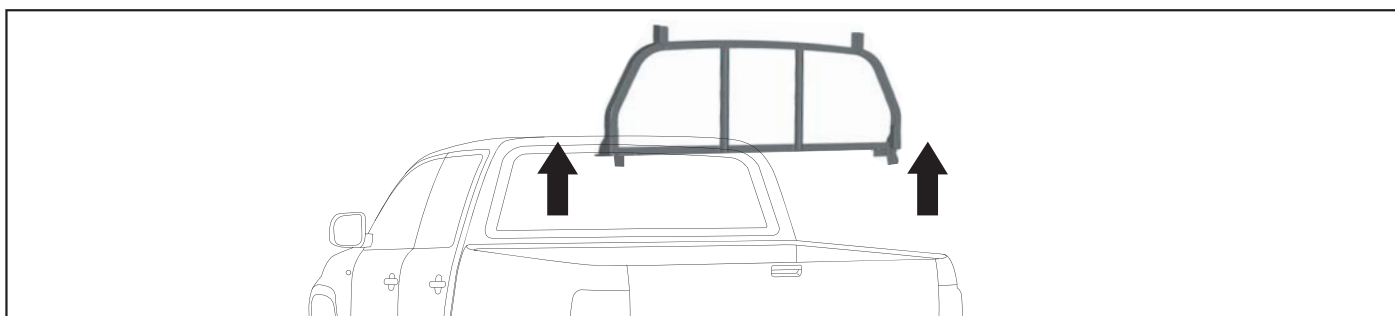

1. Remove the cabin guard from the tub.

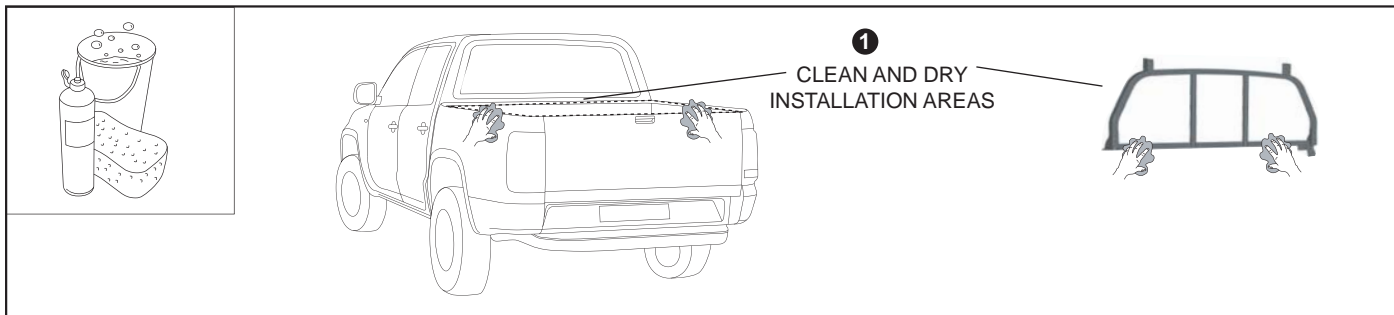

2. Thoroughly clean and dry the installations areas of the tub and cabin guard.

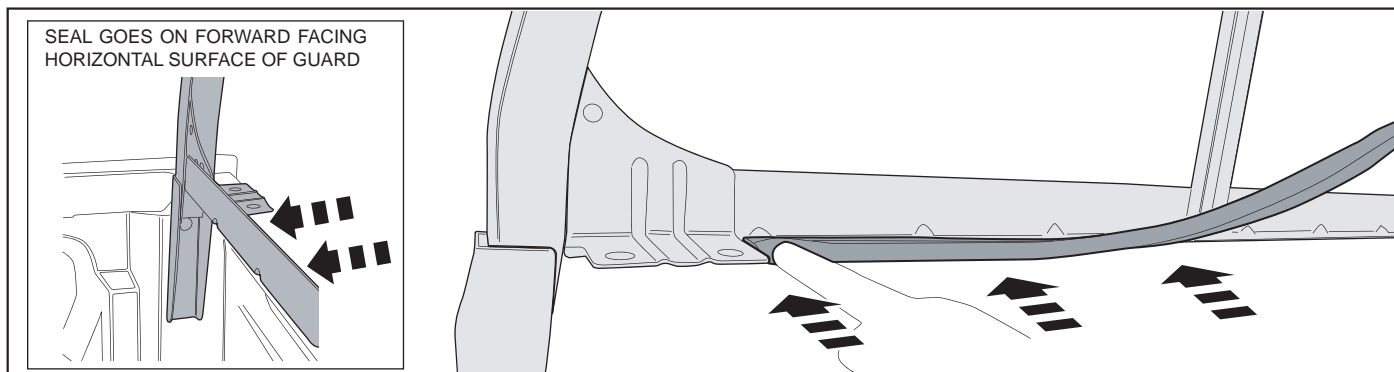

3. Install the cabin guard seal on to the cabin guard front area.

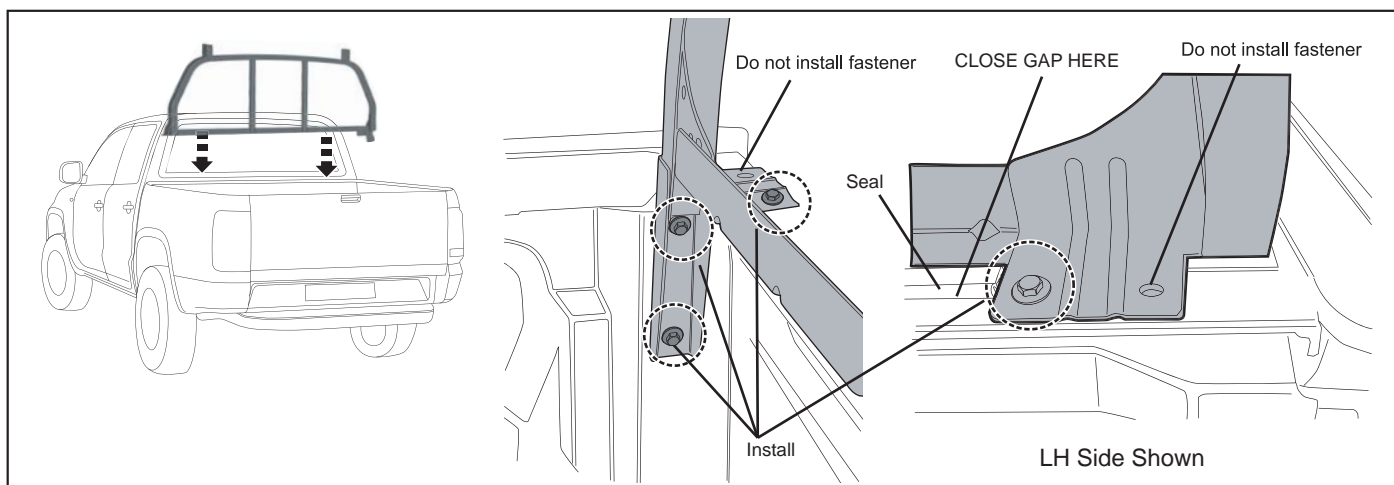

4. Install the cabin guard back on to the tub. (Ensure that the front gaps between the tub front board and the cabin guard are eliminated). **NOTE: Only install the screw on the inside of the cabin guard.**

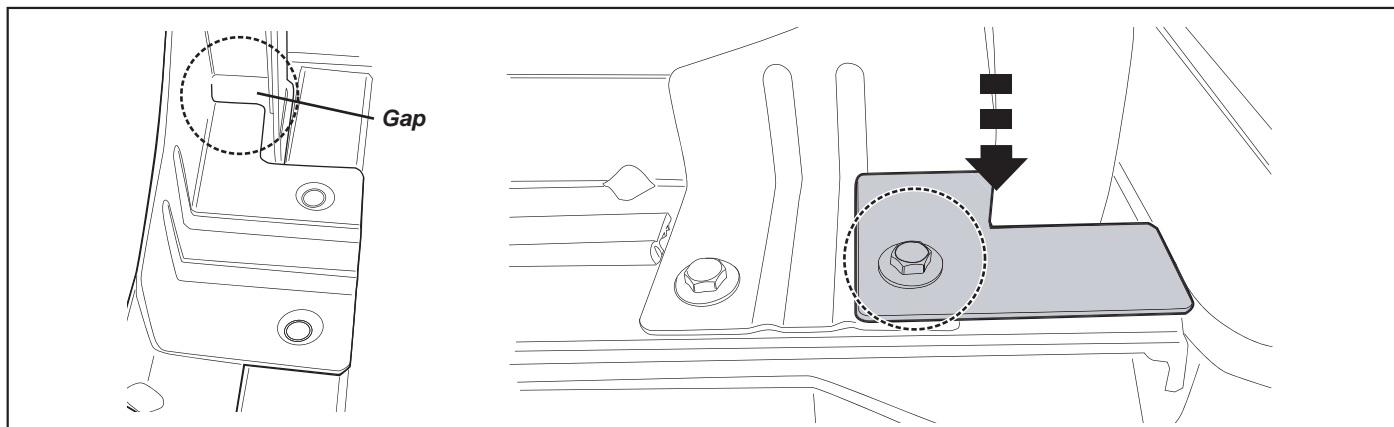

5. Place the front brackets in the corresponding pockets of the cabin guard. Align the brackets to close the gap and tighten them.

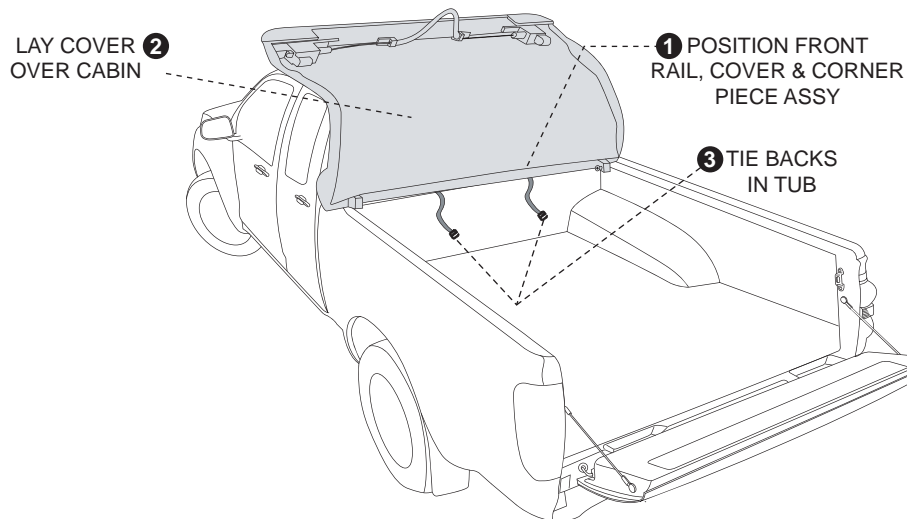

- 6.** Position the front rail at the front of the tub. Carefully lay the cover over the vehicle cabin. Ensure Tie Backs are in the tub.

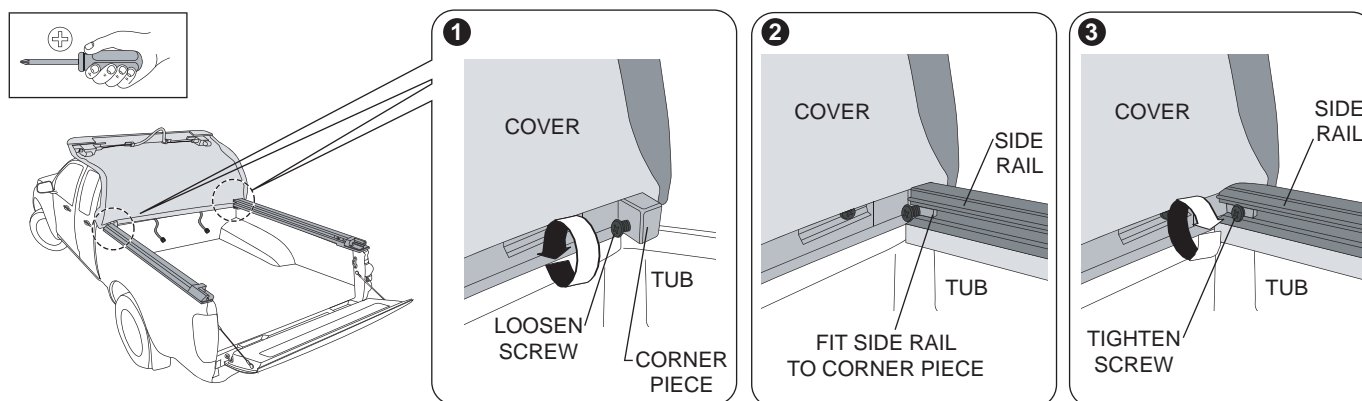

- 7.** Loosen screws (ensuring they do not disengage from the backing nuts) on each side of the front rail corners. Engage the side rails into the front rail corner pieces ensuring they are fully seated. Tighten screws on both sides to firmly clamp the side rails to the front rail.

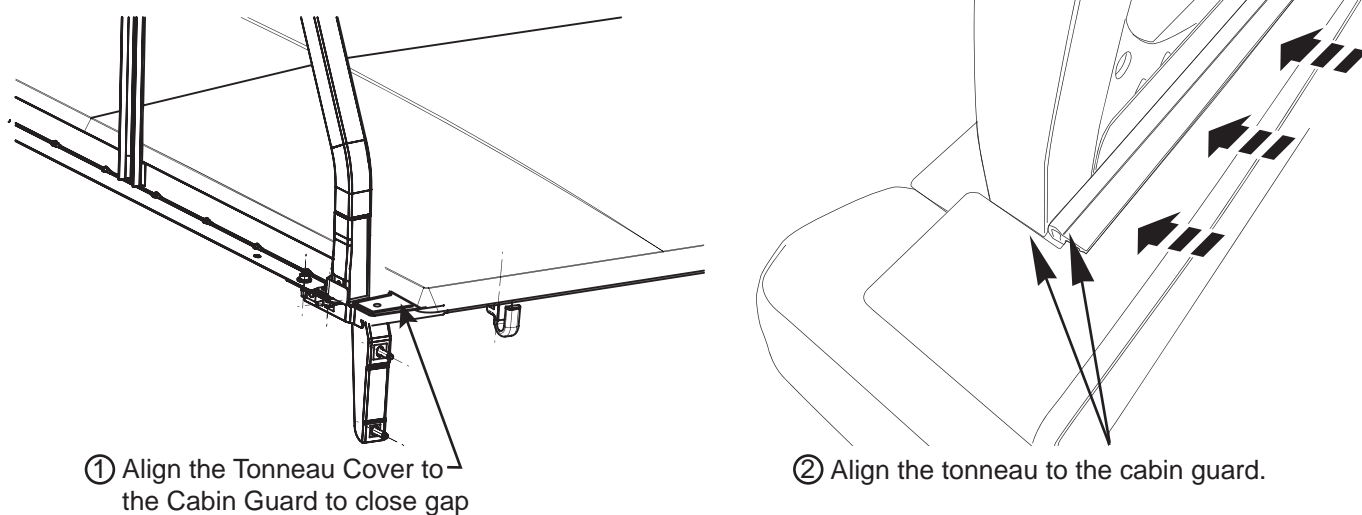

- 8.** Align the Tonneau to the cabin guard legs to close the gaps.

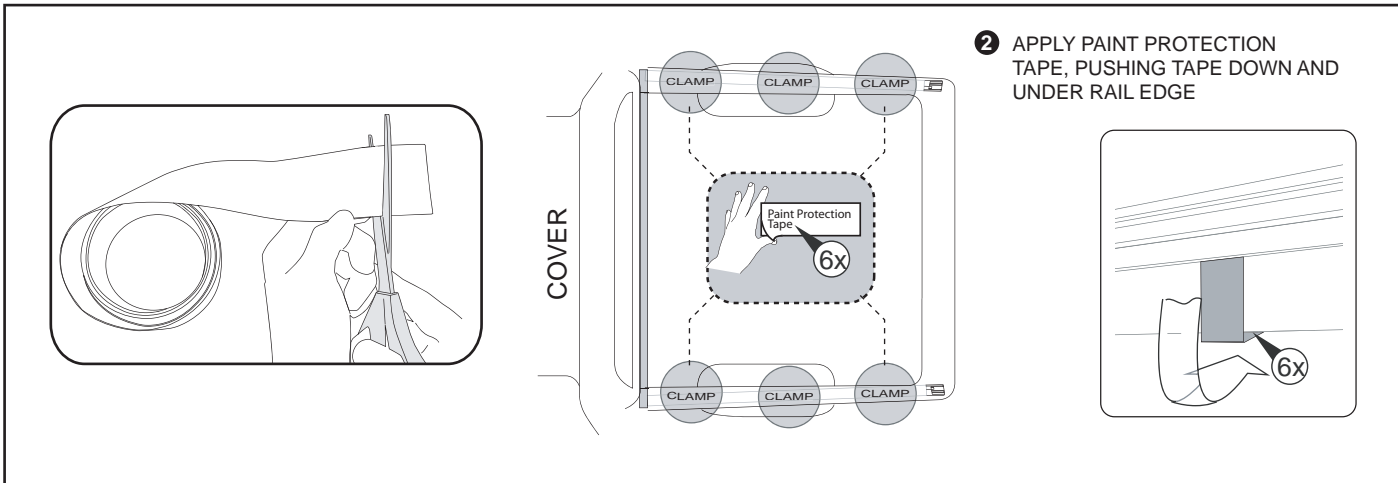

2 APPLY PAINT PROTECTION TAPE, PUSHING TAPE DOWN AND UNDER RAIL EDGE

9. Cut out 4 sections (each of width 30mm) of Protection tape from the roll and apply it on the tub in the location marked 'CLAMP' on the side rail.

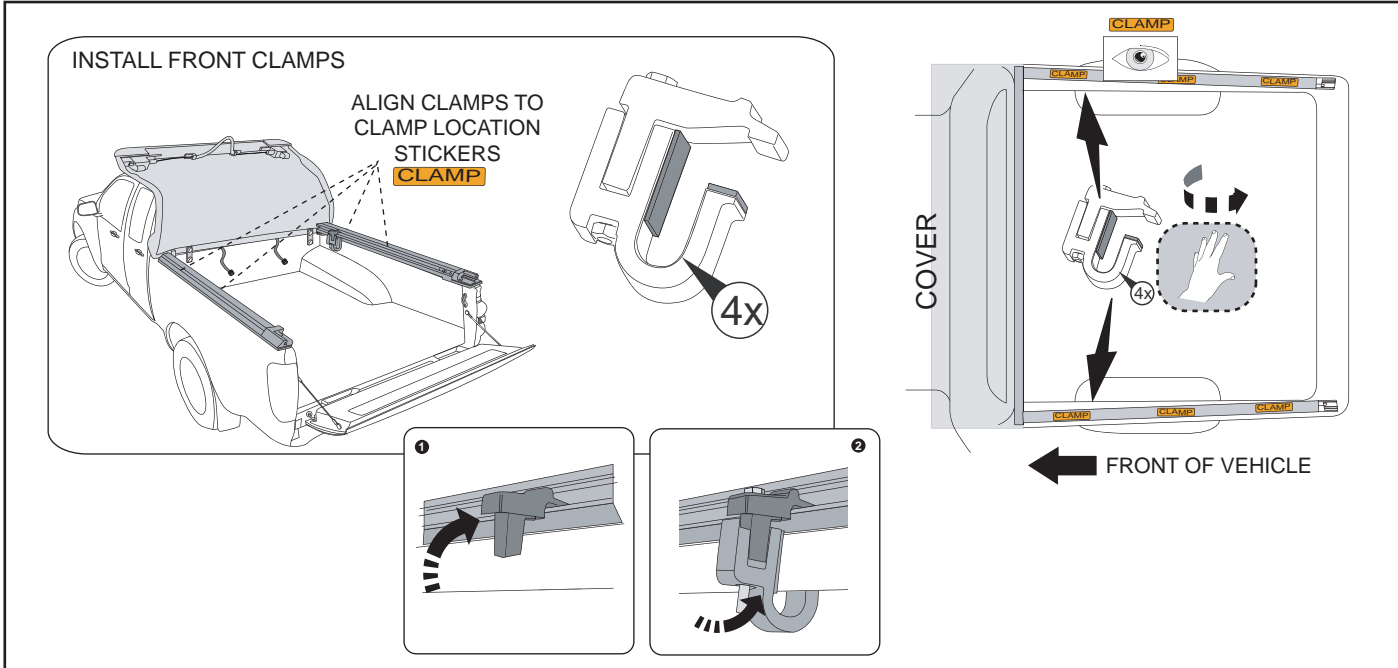

10. Using the clamp location stickers on the side rails, mount Front Clamps to the tub body ensuring that the side rails are flush with the outside of the tub body.

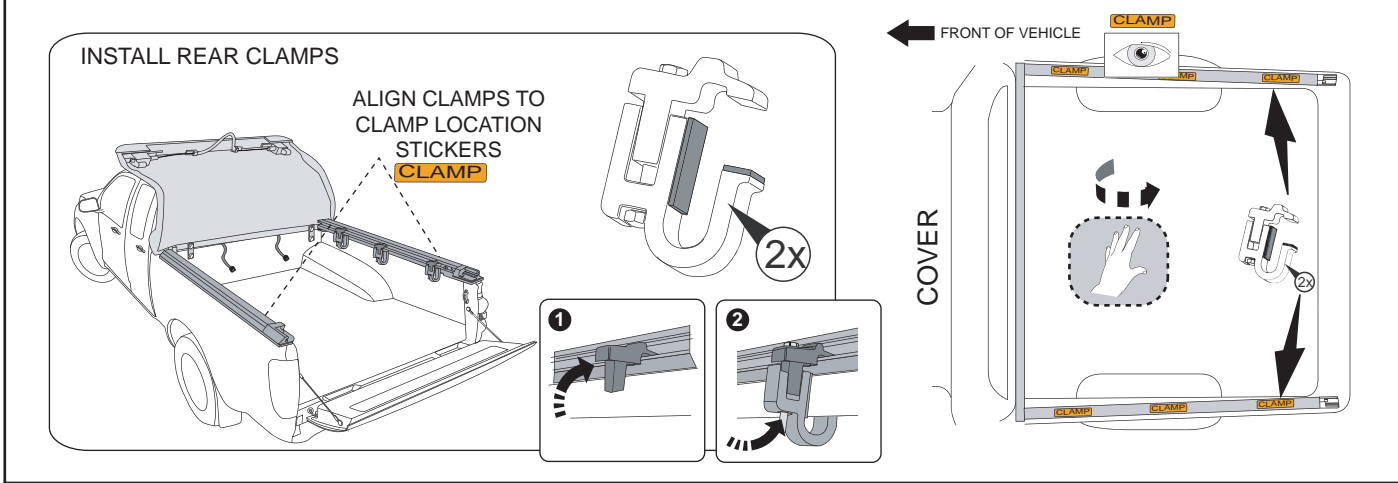

11. Repeat process and install Rear clamps the side rails and tub ensuring that the side rails are flush with the outside of the tub body.

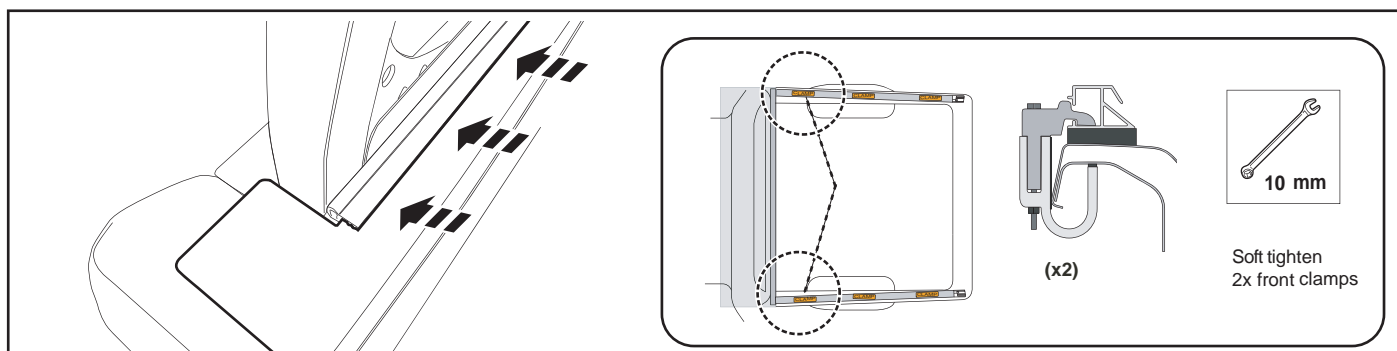

- 12.** Push the SFTC Front plate / siderails forward against the cabinguard to close any gap between them. Soft tighten the Front clamps.

ALIGN SIDE RAILS, CHECK LATCH ENGAGEMENT AND TIGHTEN CLAMPS

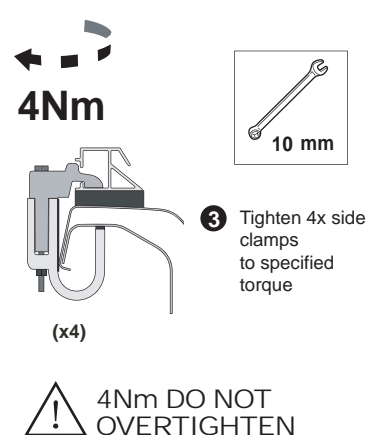
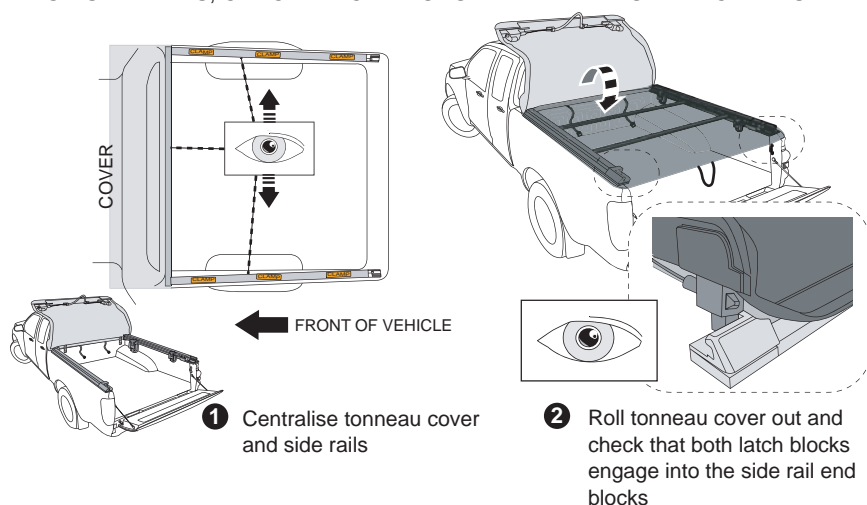

- 13.** Centralise and align side rails. Check position of side rails by rolling Tonneau Cover out and ensuring that the side latches engage into side rail blocks on rear of Tonneau Cover. When correctly aligned lay cover back on the vehicle roof and tighten both front and rear side clamps to the torque specified.

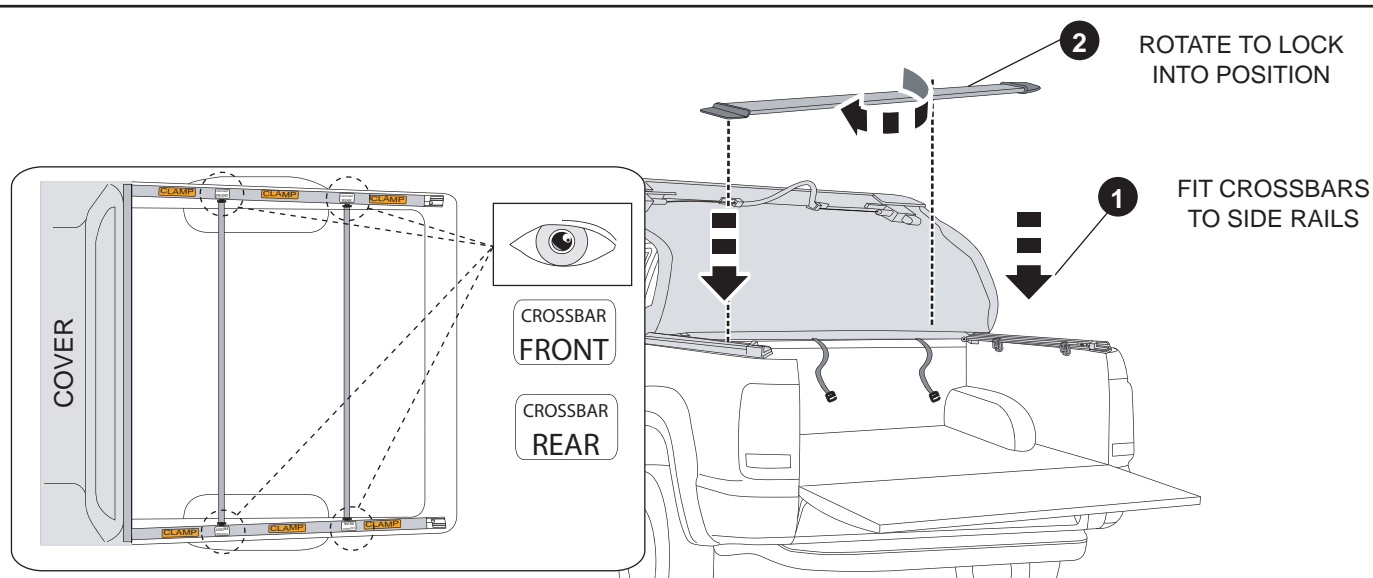

- 14.** Fit the Cross Bar marked 'Front' closest to the Cabin & the Cross Bar marked 'Rear' closest to the Tailgate. Note identification stickers on side rails showing positions.
NOTE: Crossbars must be fitted as instructed to assist Water Drainage. Failure to fit Crossbars may result in Damage and void Warranty.

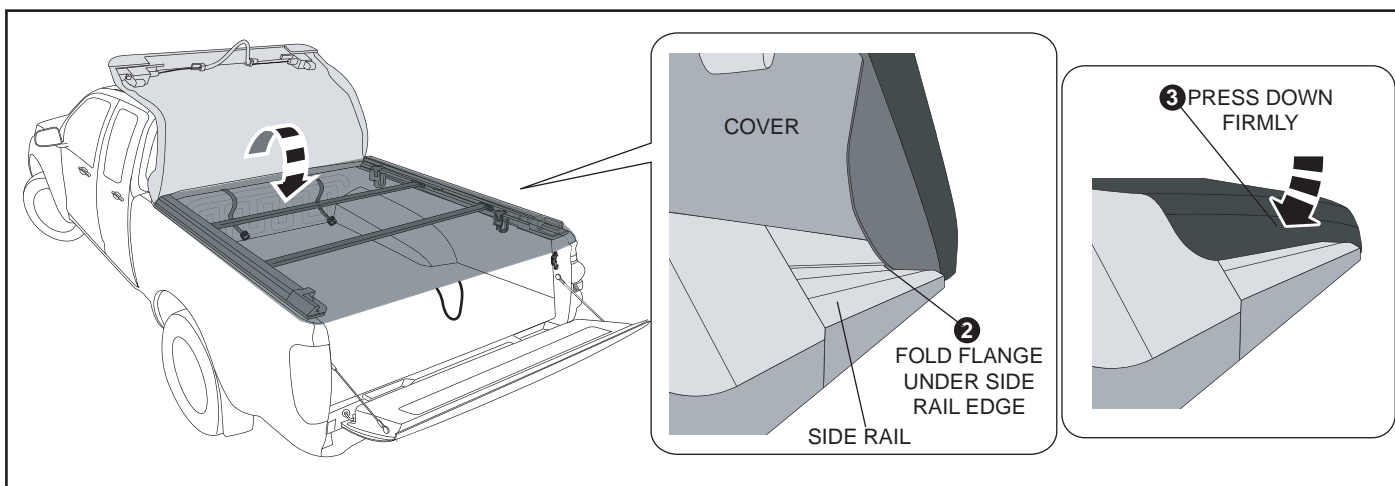

- 15.** Roll cover over tub towards the rear of the vehicle. Fix the cover to the side rails by folding the flexible flanges on the cover outward and rolling them in under the edge of the side rails. To lock them in press firmly on the outside of the cover.

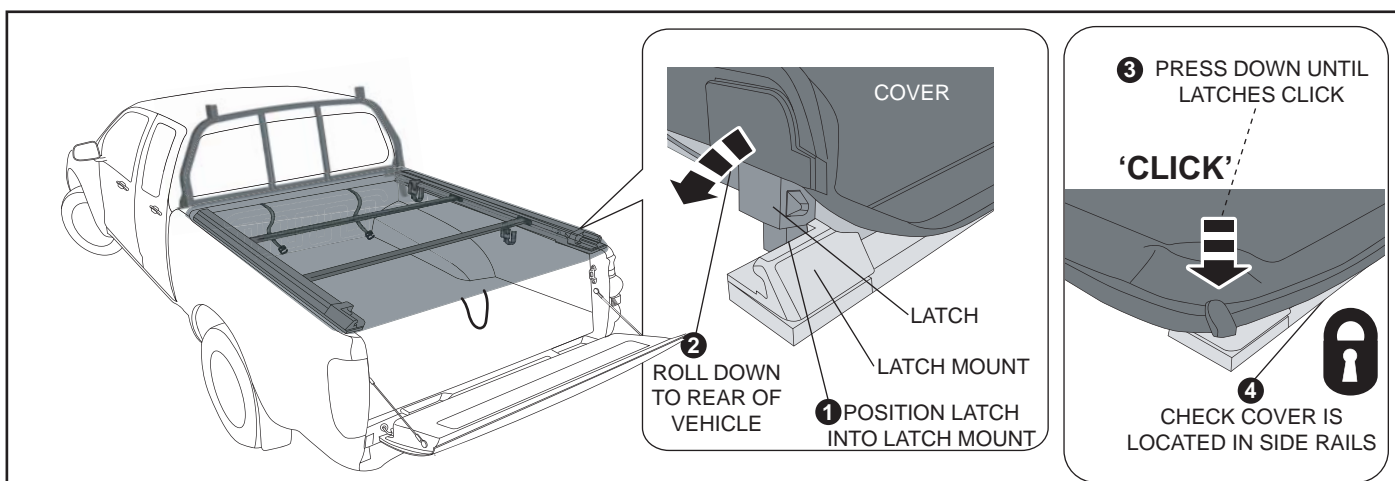

- 16.** Position latches into stretch mounts. Holding the cover rail at the rear, roll towards the rear of the vehicle and down until latches click and are both locked into position. Ensure the flexible side flanges are fully seated into the side rails.

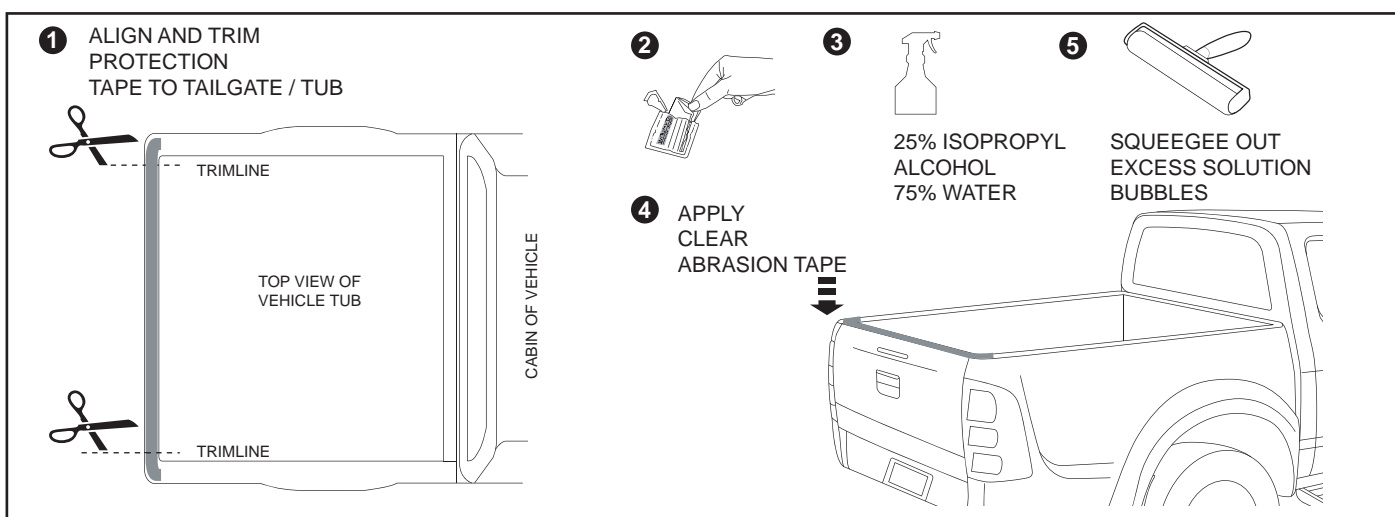

- 17.** Open the tonneau. Align and trim the Paint Protection Tape so that it covers the tub / tailgate area where the tonneau rear rubber seal comes in contact. Clean the area with alcohol wipes. (Not supplied) Using a solution of 25% isopropyl alcohol and 75% water in a spray bottle (not supplied) thoroughly spray along the top of tub/tailgate. After removing the liner from the Paint Protection Tape, place it on the tub (The tape won't stick since it is in contact with the solution). Align the tape. When in position use a squeegee to push out the excess solution and bubbles. You may need to squeegee a few times. When finished the tape is virtually invisible.



IMPORTANT STEP FOR SEALING TONNEAU COVER

SEAL ANY GAPS

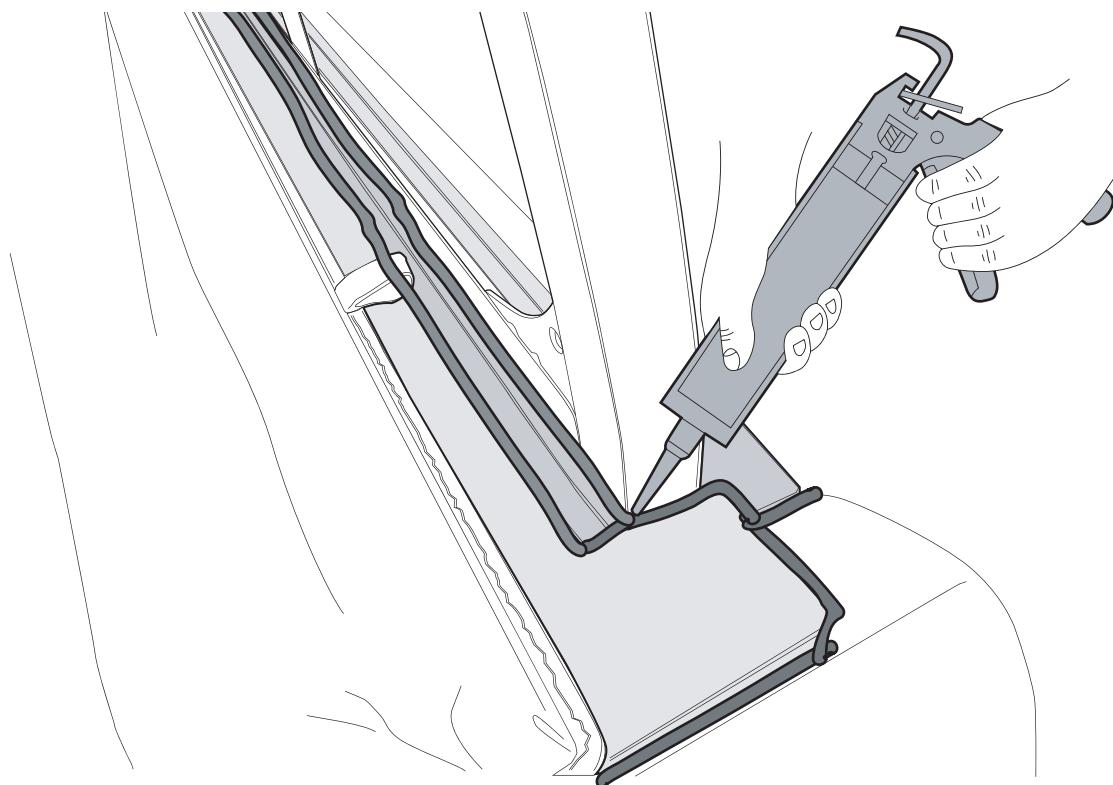
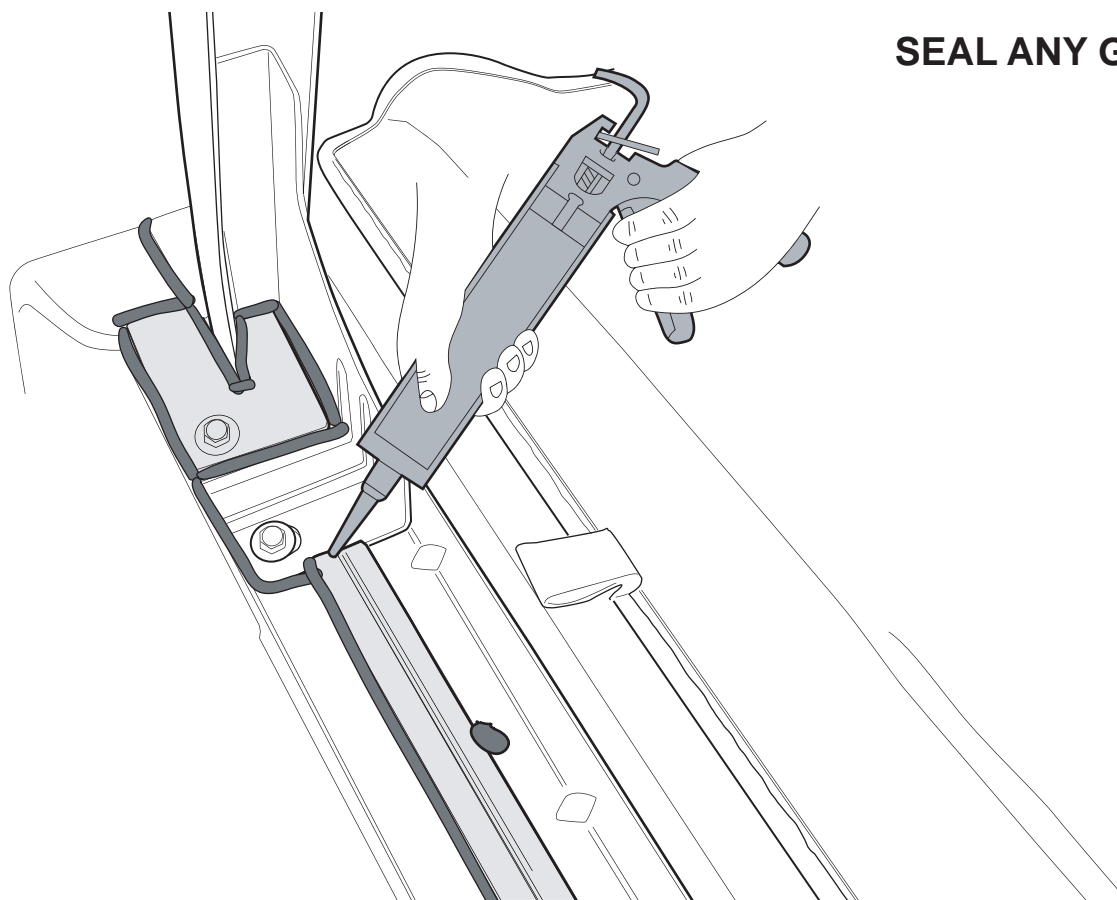

18. Seal all the gaps in and around cabin guard by applying Silicon gel (Not supplied). Allow the silicon gel to dry before any activity. This step is important, as it minimises leakage into the tray body in wet conditions.

INSTRUCTIONS TO ROLL BACK SOFT TONNEAU COVER

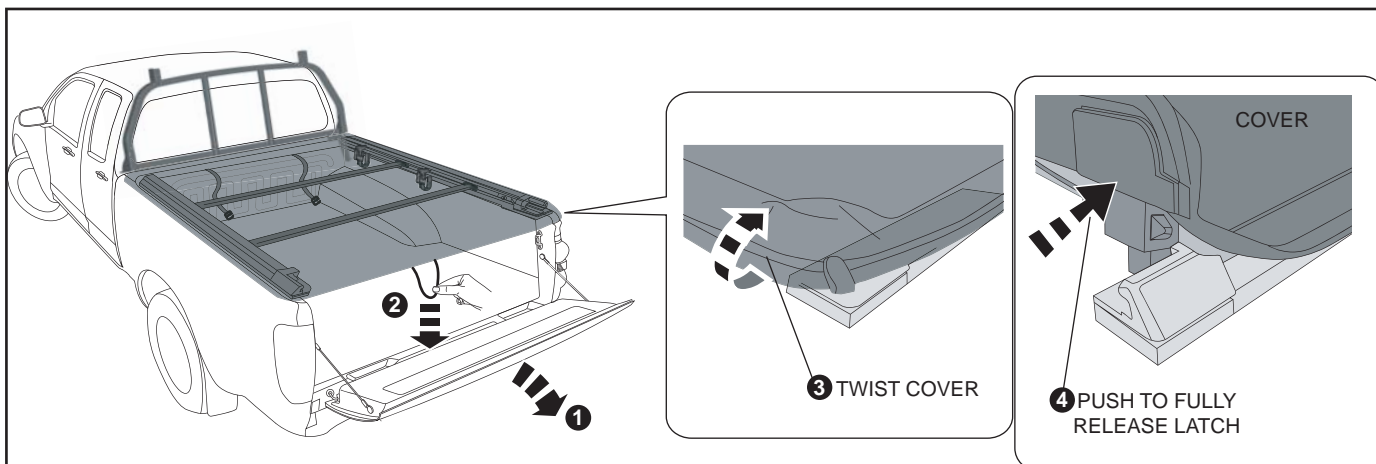

1. Open rear tailgate. Locate latch release tab under the centre rear of the cover and pull in a downward direction to disengage the latches. Twist the rear rail upward to completely release the latches.

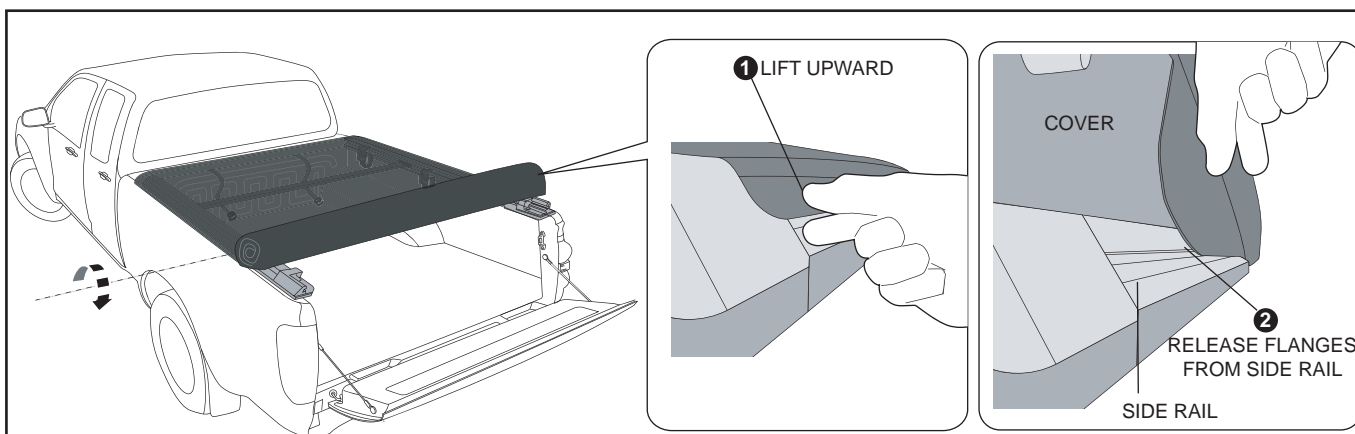

2. Working from the Rear to the Front of the Vehicle, Grip & Lift in an upward direction the Sides of the Cover to Release the Flexible Flanges from the Side rails.
IMPORTANT: Ensure that the flanges are released prior to rolling the tonneau, otherwise they may get damaged.

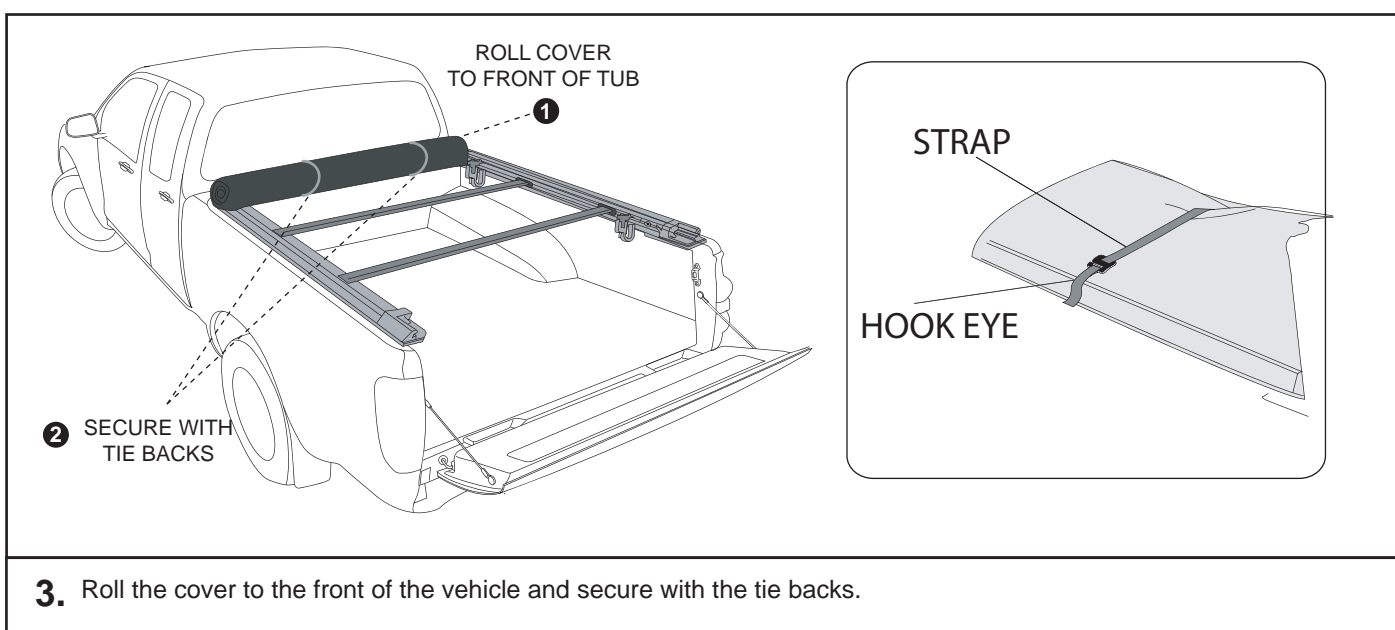

3. Roll the cover to the front of the vehicle and secure with the tie backs.

IMPORTANT

DO NOT CLOSE THE REAR TAILGATE WHEN TONNEAU COVER LATCHES ARE ENGAGED.

When Closing the Vehicle Tailgate Ensure the Tonneau Cover Latches are Dis-engaged First, then close the Tailgate.

Re-engage the Latches and ensure that the entire length of the Cover Side Flexible Flanges are firmly located into the Side Rails as per step 10.

