

VW AMAROK MY23 ➡

Installation Time: Approx. 60 Minutes

PERSONAL PROTECTIVE EQUIPMENT:



Mask



Rubber Gloves



Goggles



Hearing Protection

Care Instructions:



Clean with a mild detergent and water solution.



Do not use abrasive cleaners or solvents.

WARNING!

Securely lock Tonneau Cover or Draw Back and Securely Tie Back before operating vehicle! Failure to do so could result in unexpected opening of the Tonneau Cover from sudden wind gusts, which could cause damage to the vehicle and/or your Tonneau Cover!

MAINTENANCE

Your Tonneau Cover only requires periodic cleaning with water, neutral car wash soap and sponge or flannel. Never use any chemicals or abrasive products to clean your Tonneau Cover. Always use the Central Crossbars to give support and facilitate water drainage. The latch mechanisms only require occasional lubrication with Graphite Powder. Using alternative lubricants or oils, will void warranty.

IMPORTANT!

Read instructions carefully before installation. It is strongly recommended that installation is conducted by an authorized dealer.

- This product must be installed exactly as specified in these instructions. Failure to do so may result in improper fit and/or retention.
- Do not stand/sit or rest heavy objects on Tonneau Cover.
- Do not carry Sharp or Pointed Material, or Material that exceeds Bed Height with Tonneau Cover closed.
- Humans or animals are not to be under the closed Tonneau Cover at any time.
- Securely lock Tonneau Cover before operating vehicle.
- Do not carry open volatile chemicals with Tonneau Cover installed.
- If contact with volatile chemicals occurs clean Tonneau Cover with mild detergent and water solution.
- This product is water resistant, but may not be fully waterproof.

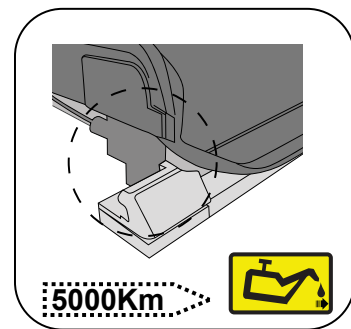

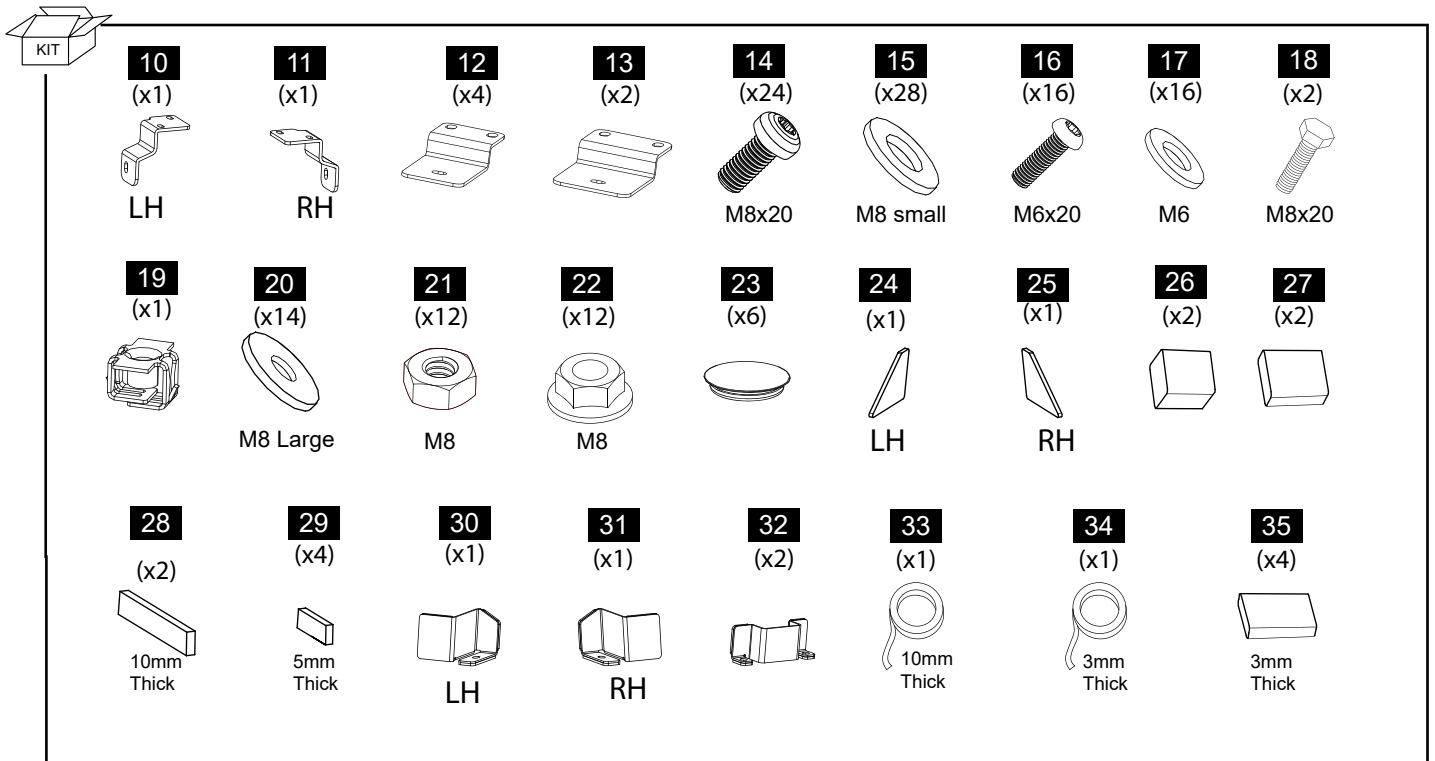
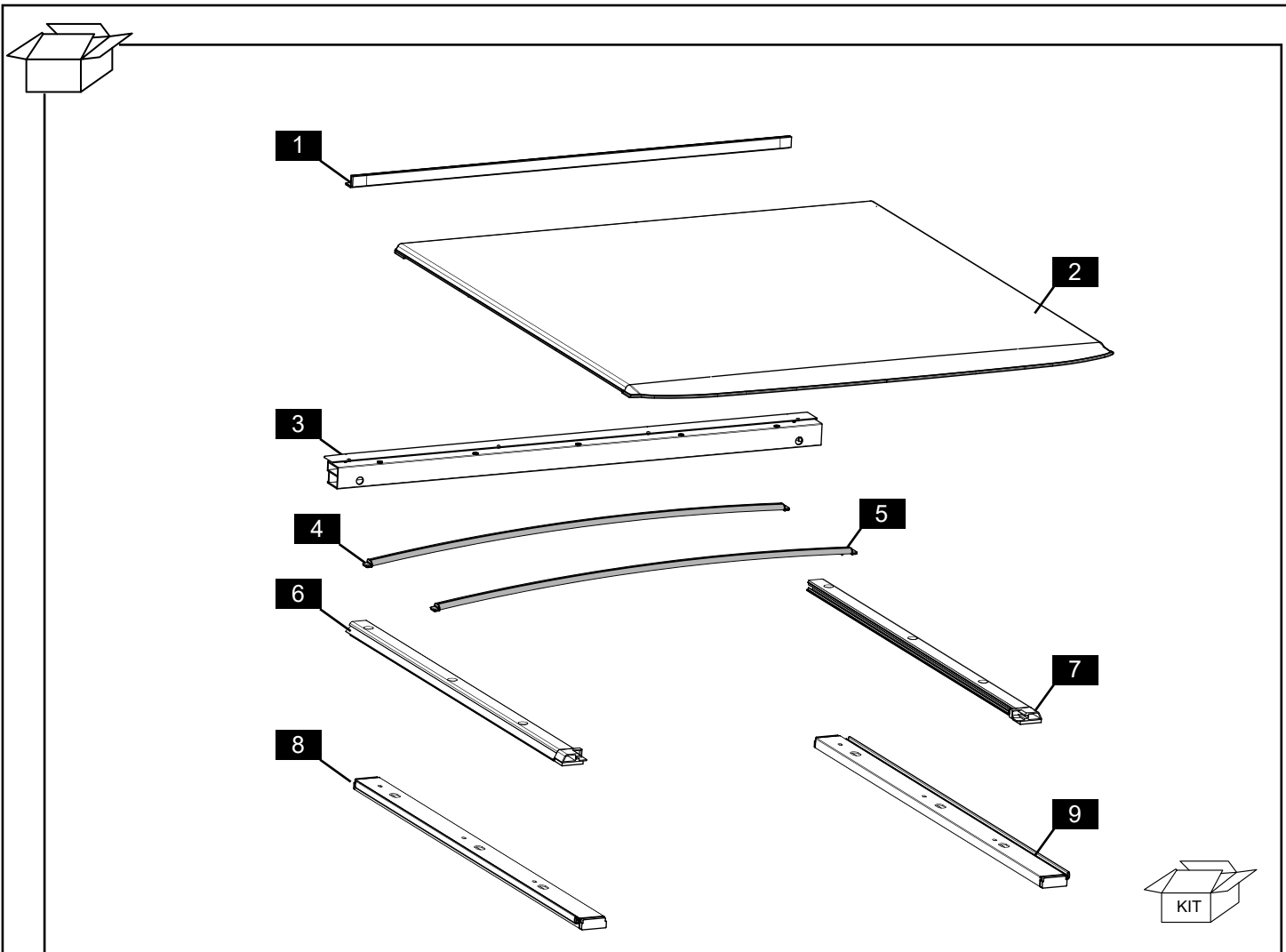

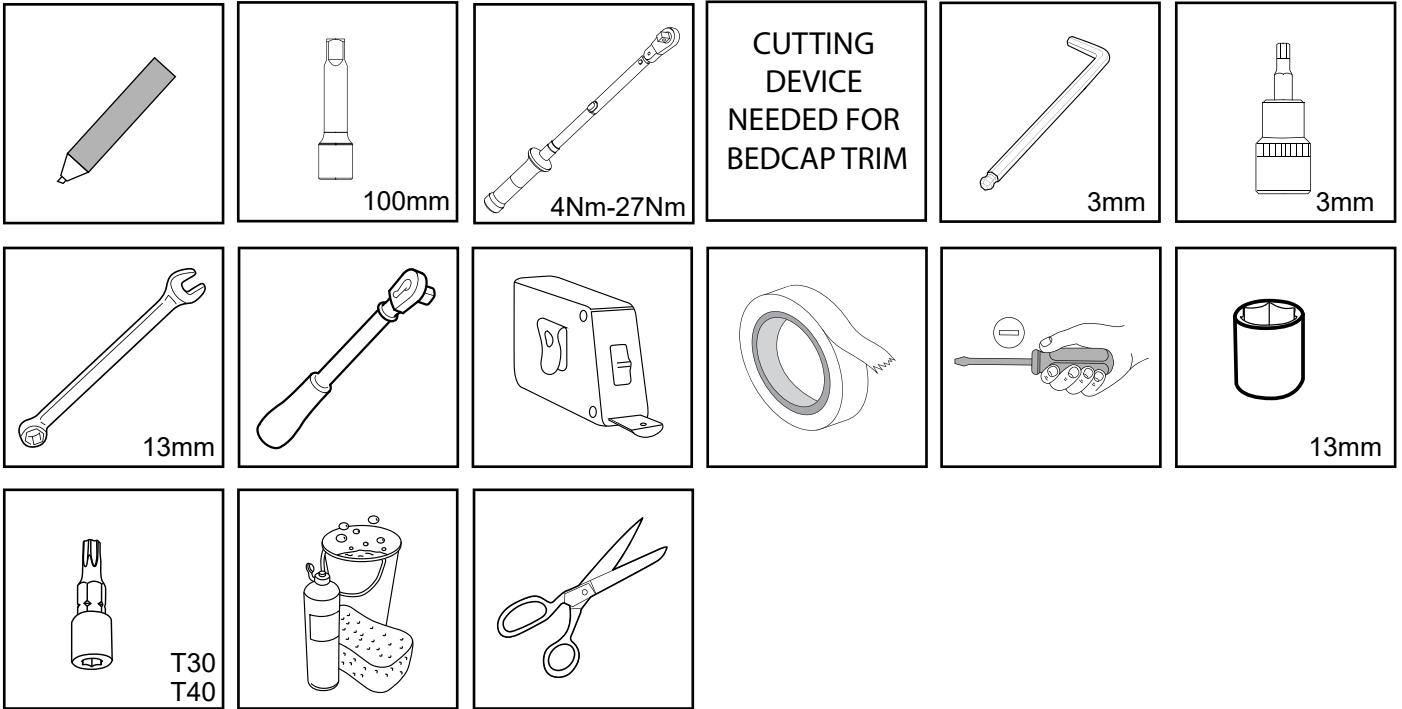
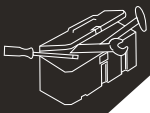

GLOSSARY

	: Vehicle Part		: Location
	: Sequence		: Loosen
	: Part Provided		: Adjust
	: Torque Setting		: Install / Remove
	: Even Space		: Equal
	: Reuse		: Disconnect
	: Discard		: Connect
	: Complete for Both Sides		: No Torque
	: Two People		: Lock
	: Check		: Unlock
	: Caution		
	: Clean		

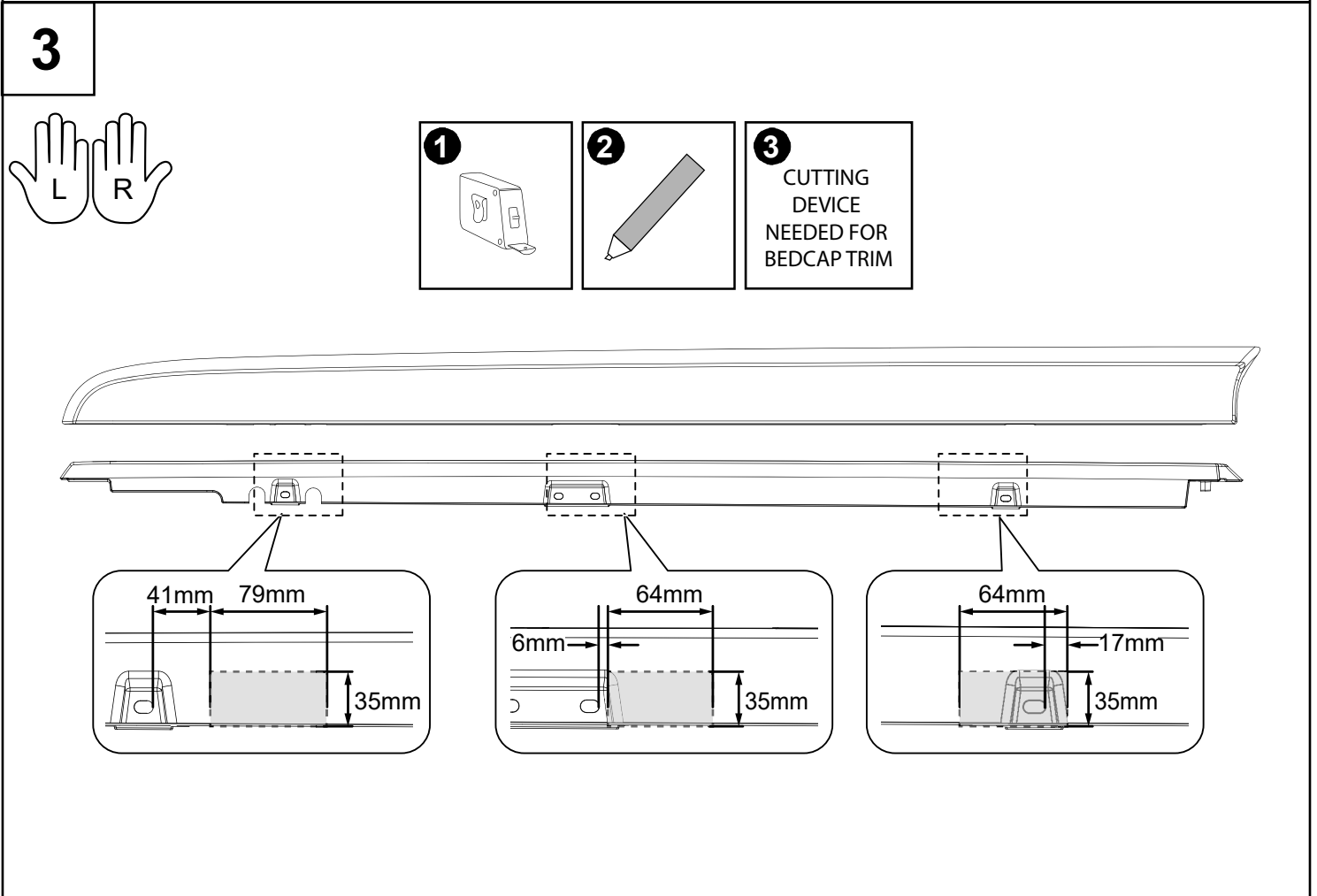
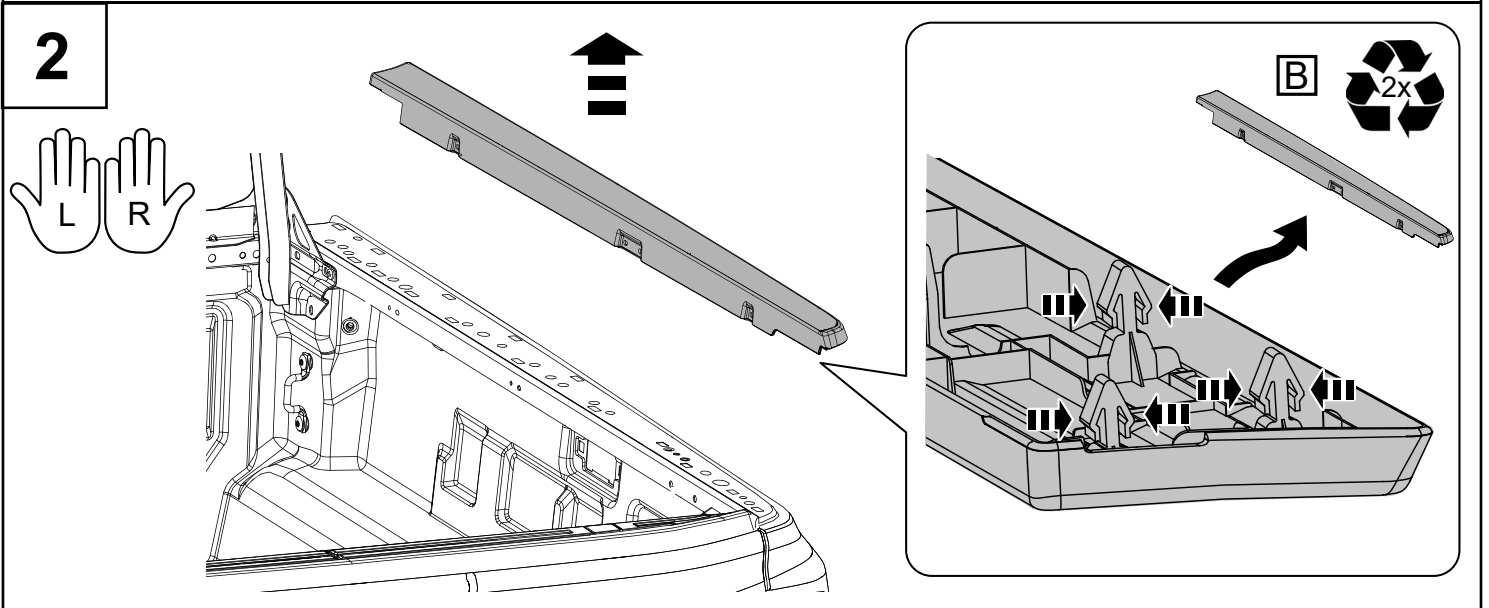
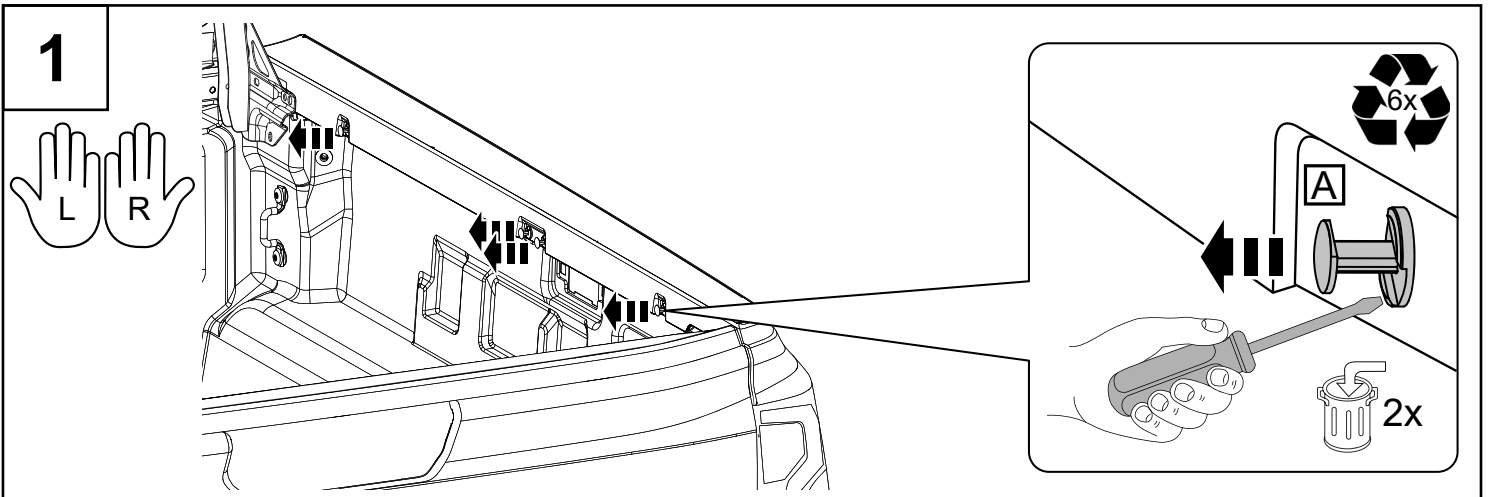

4

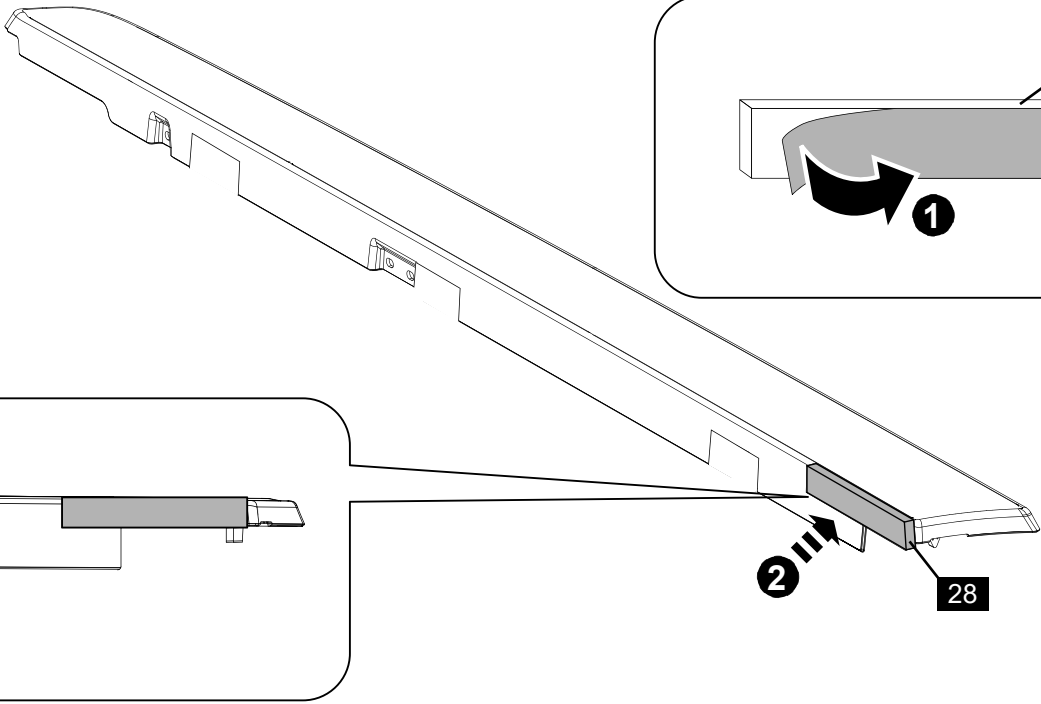
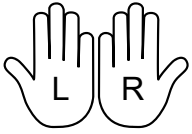

5

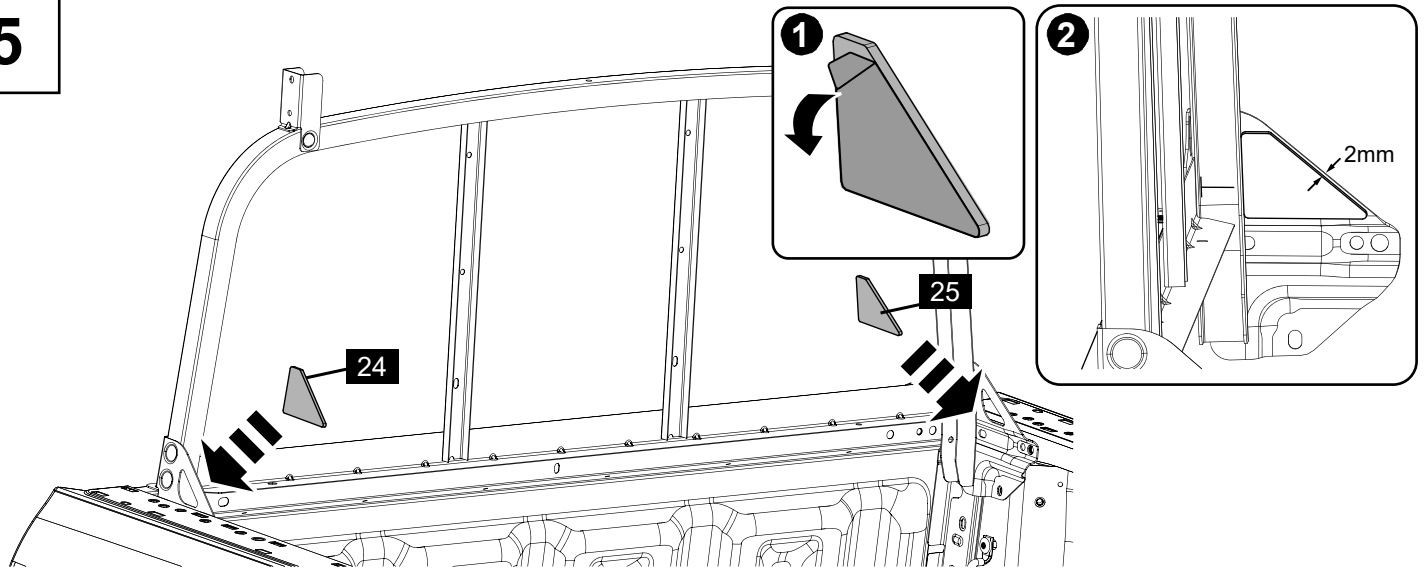

6

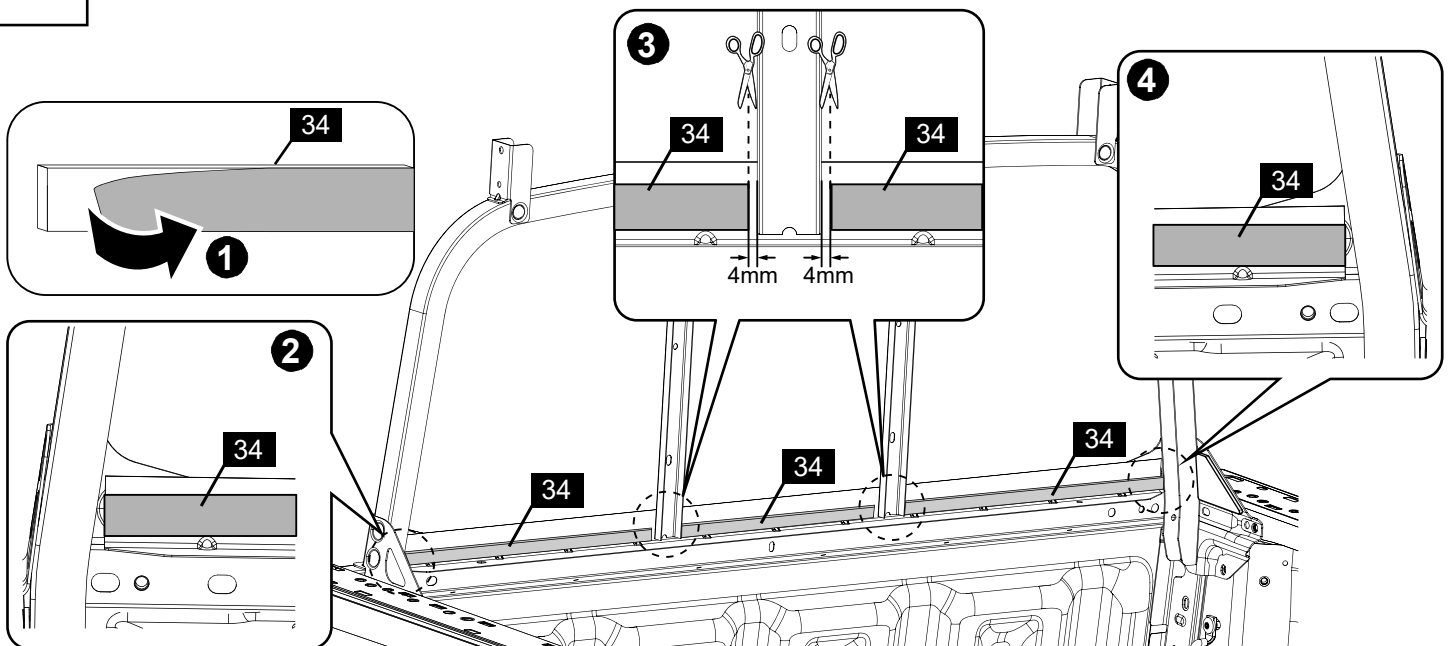

7

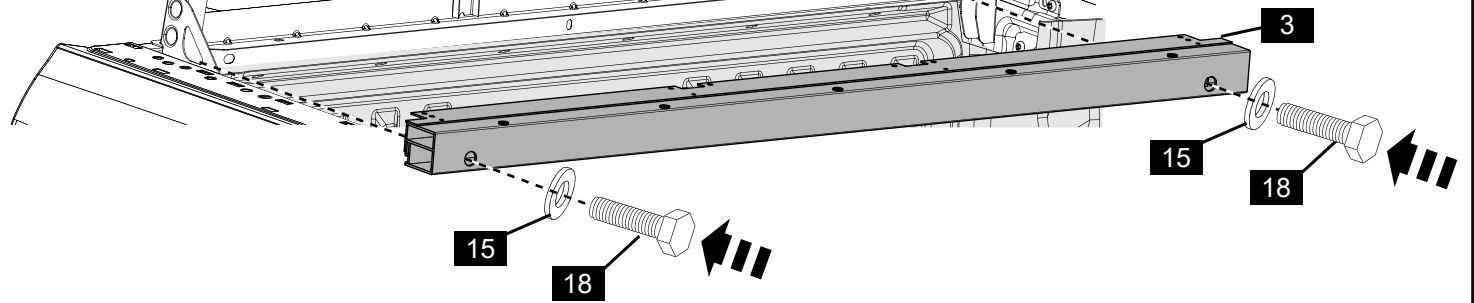
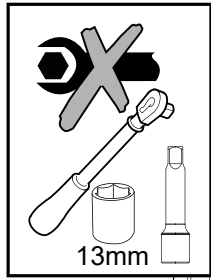

8

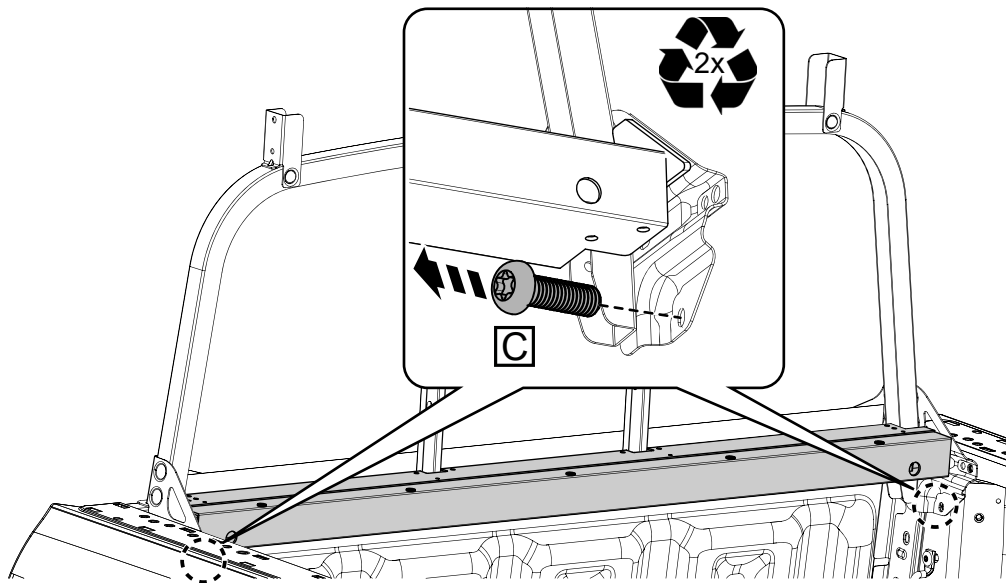
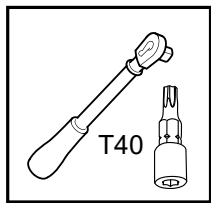

9

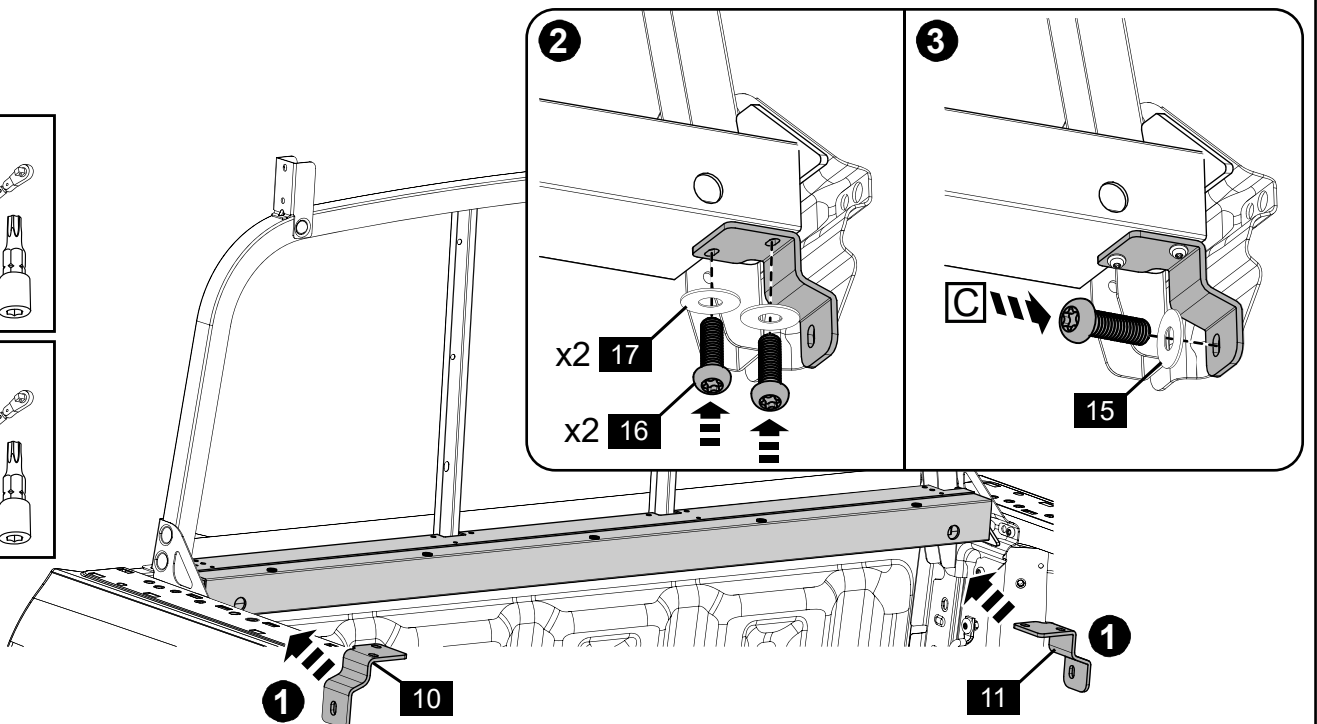
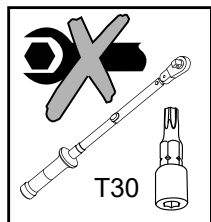
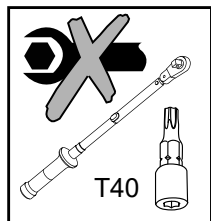

10

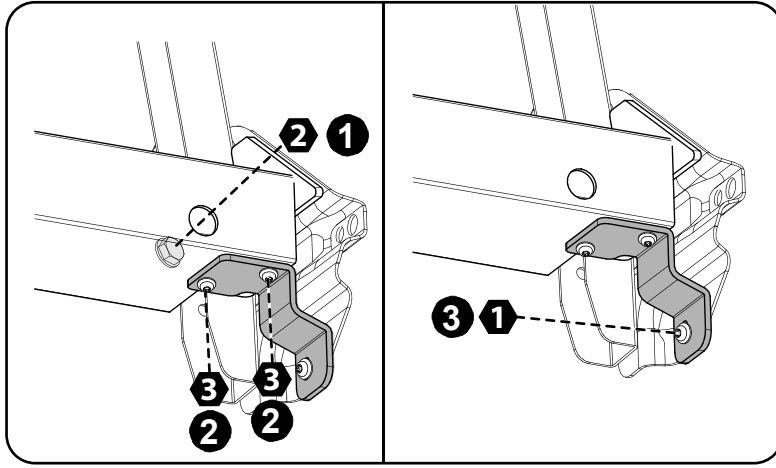
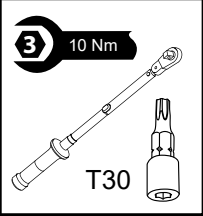
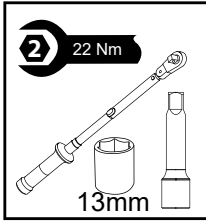
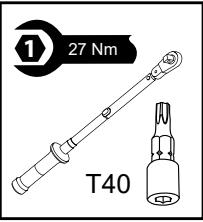

11

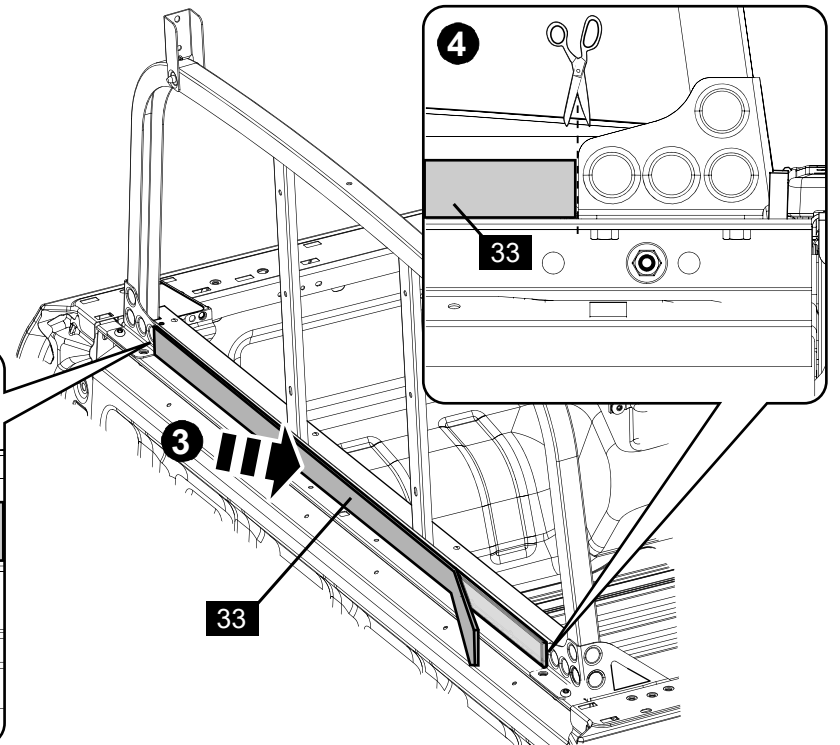
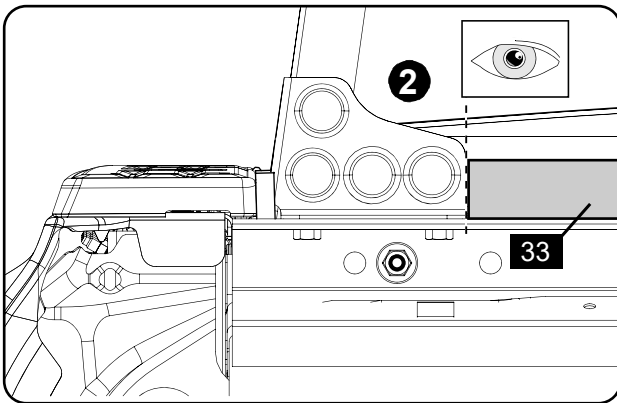
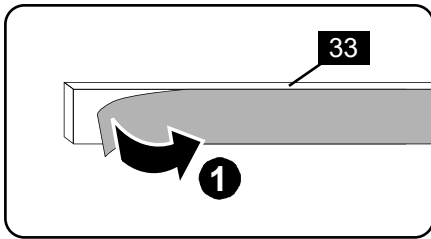

12

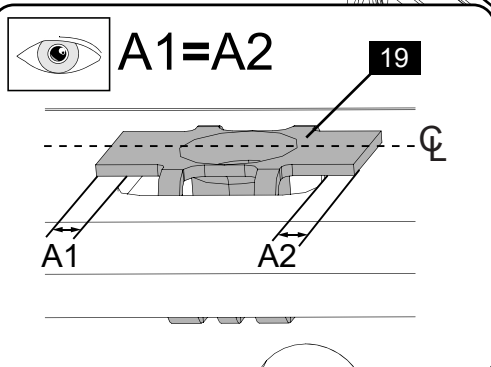
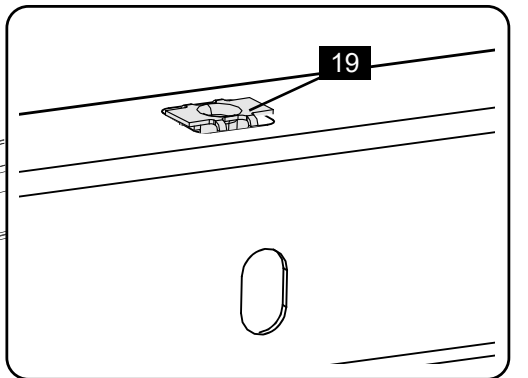
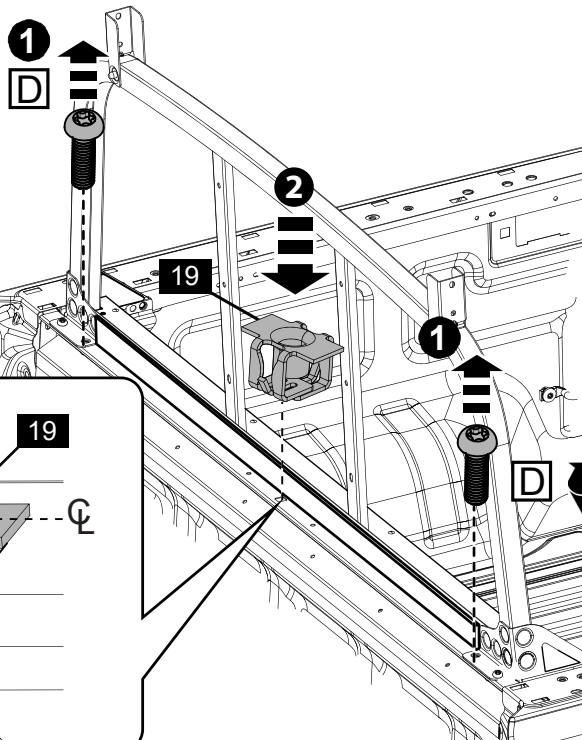
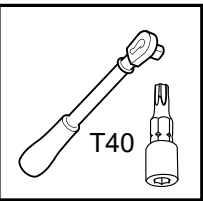

13

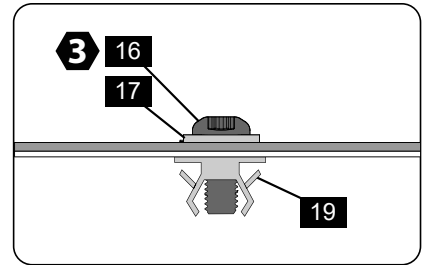
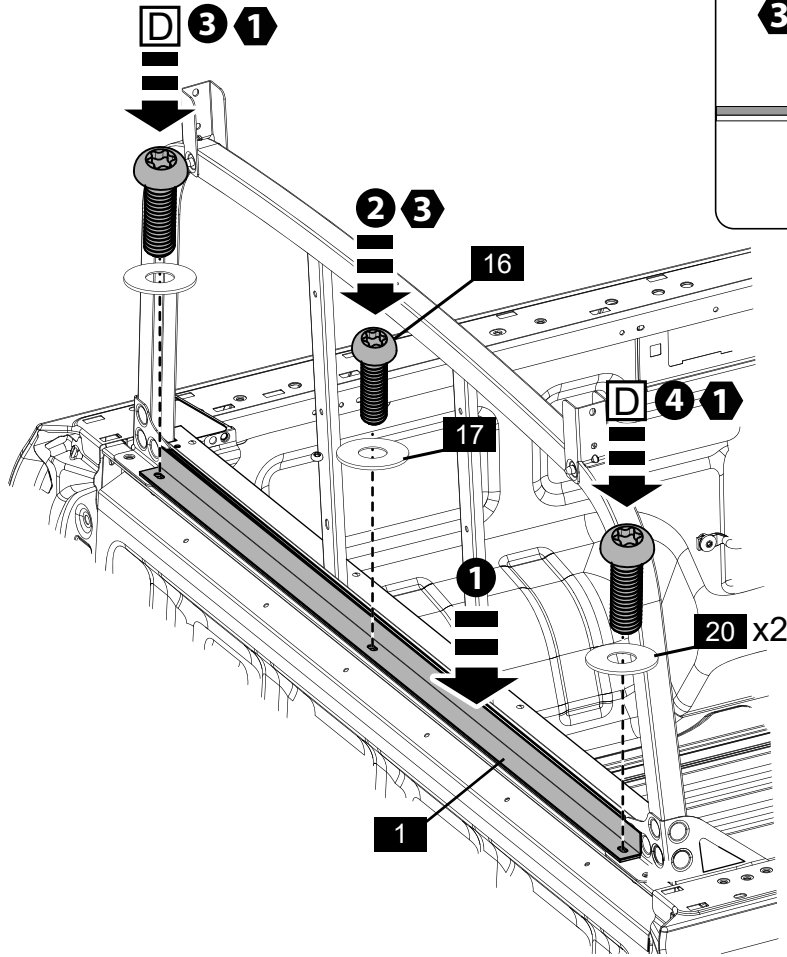
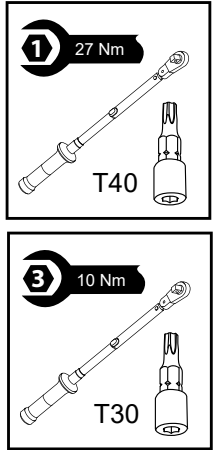

14

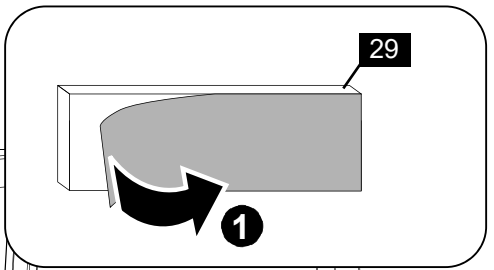
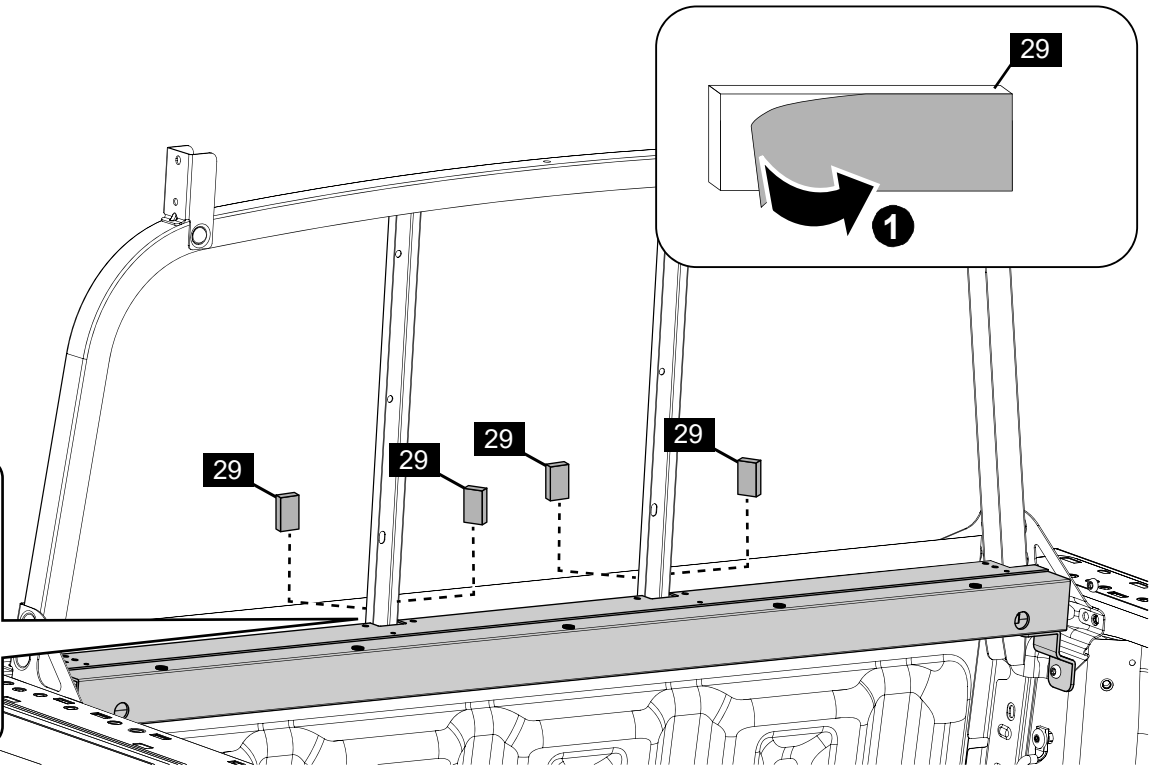
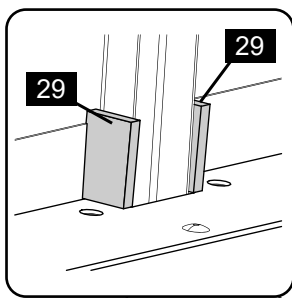

15

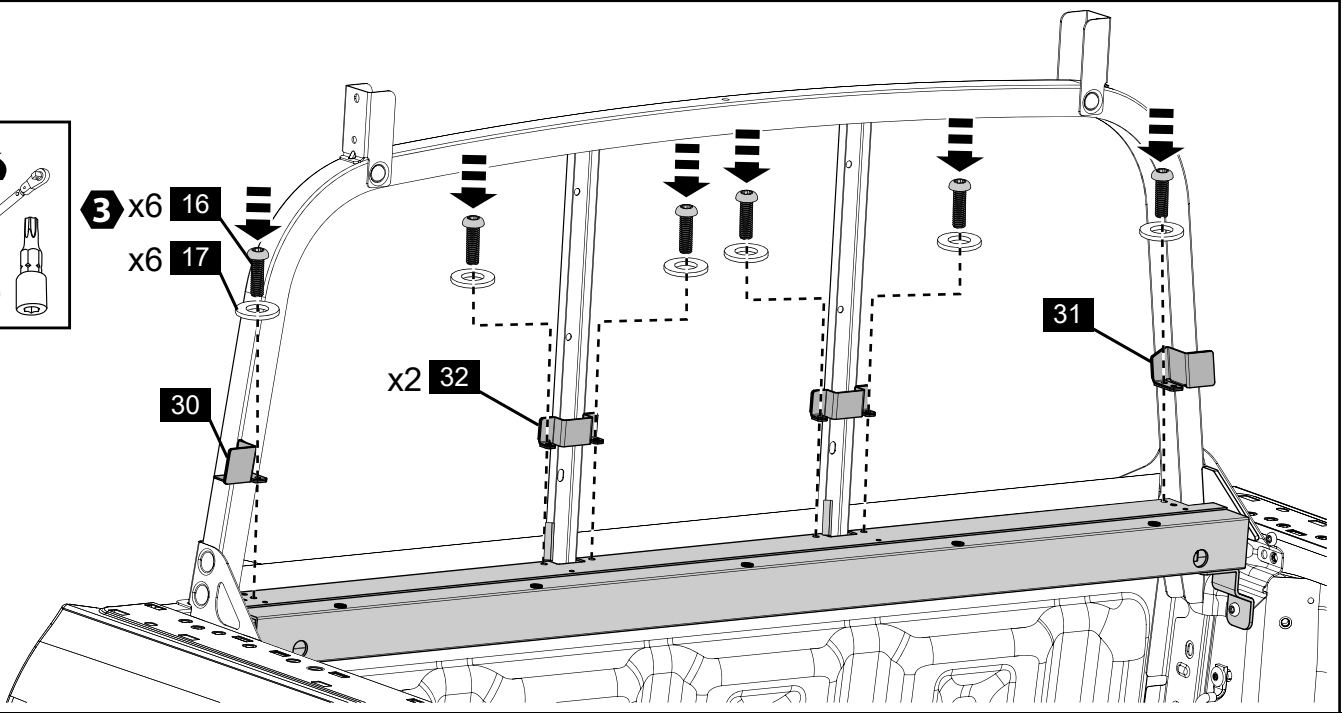
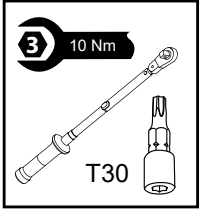

16

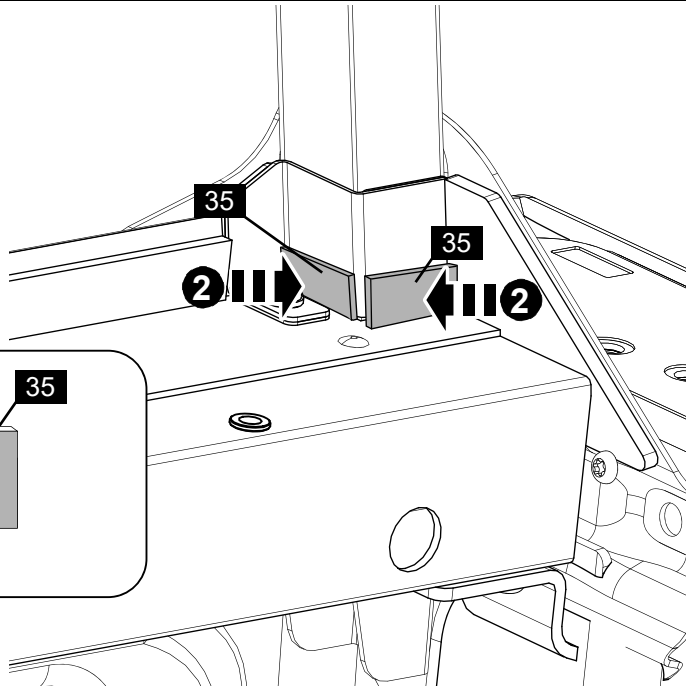
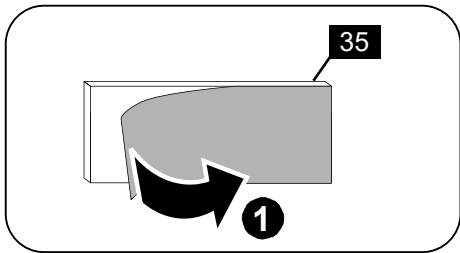
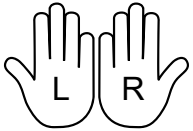

17

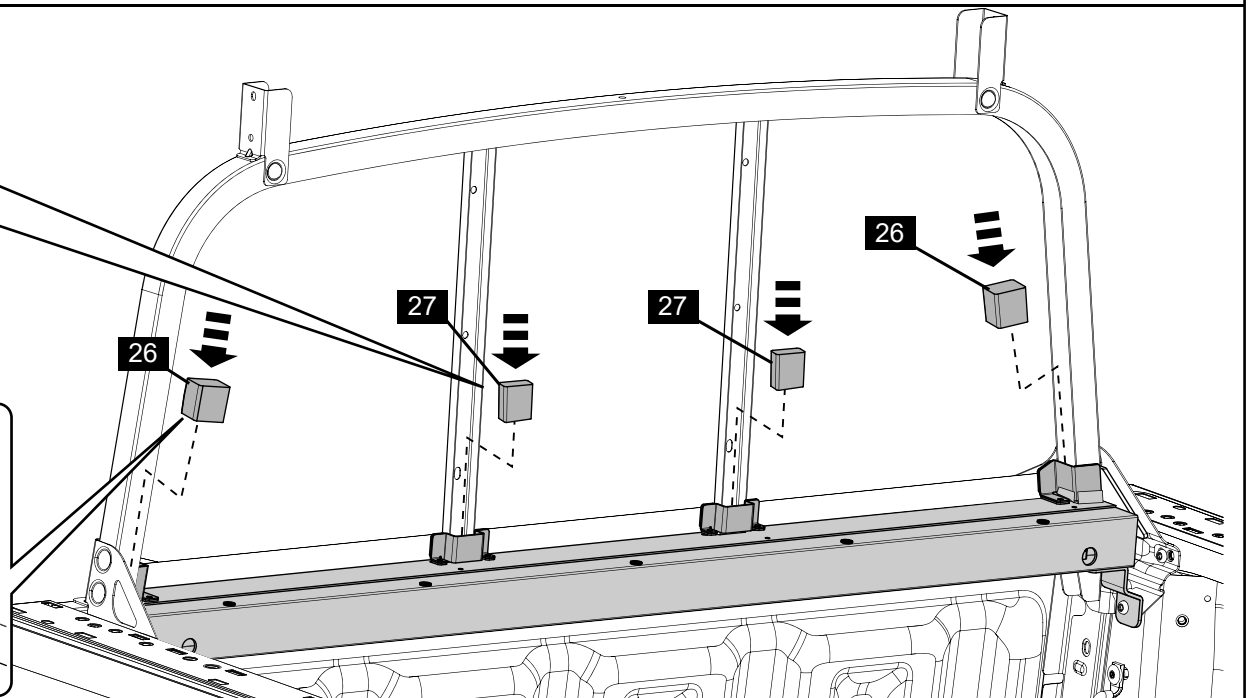
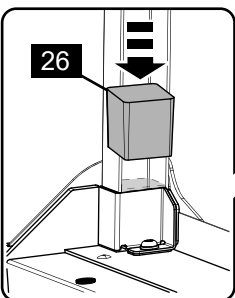
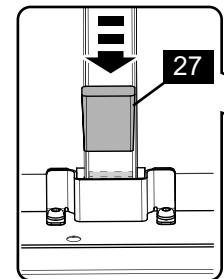

18

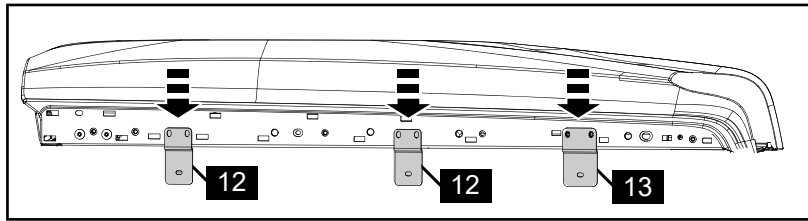
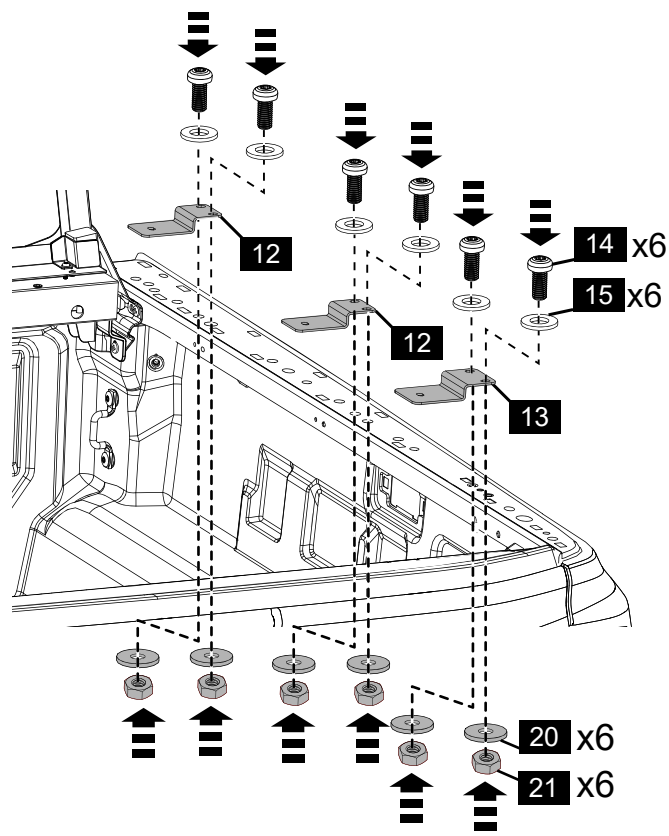
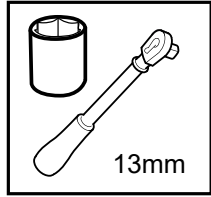
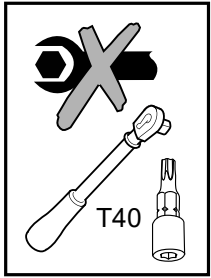

19

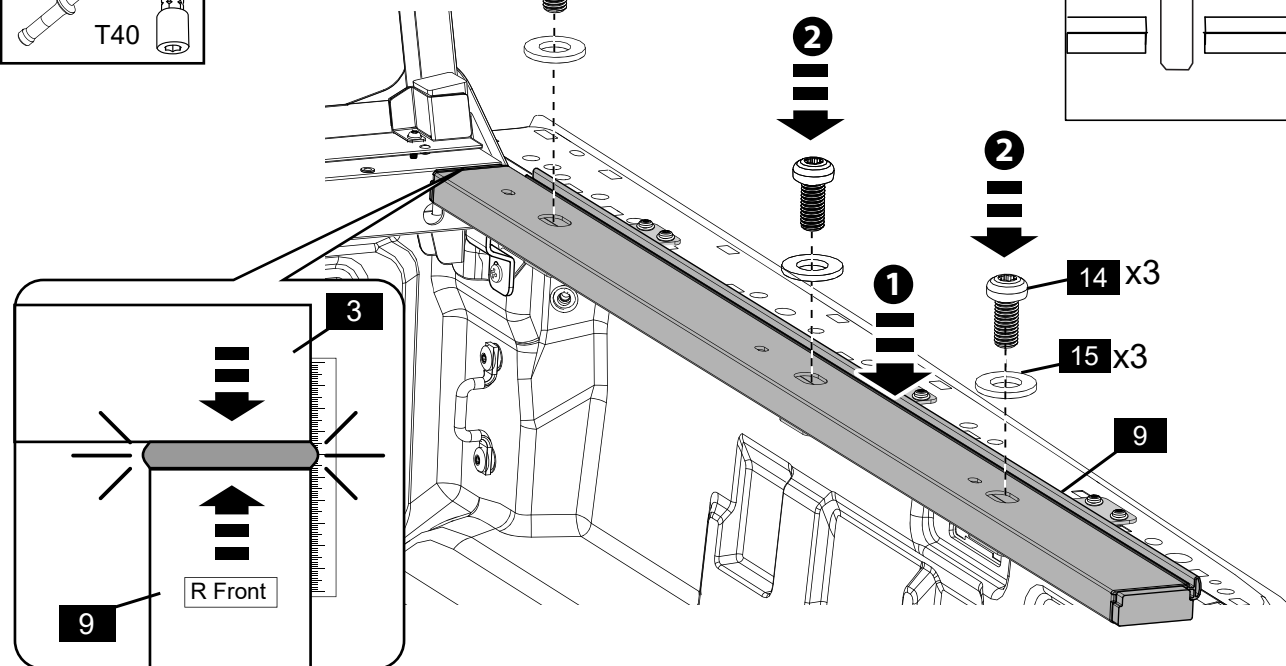
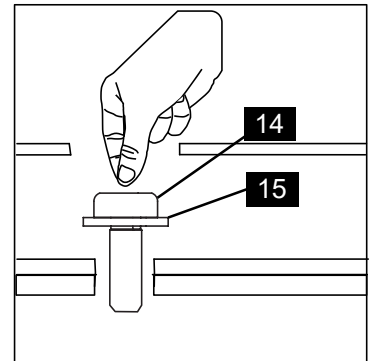
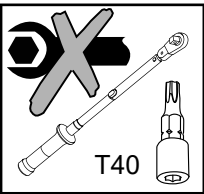

20

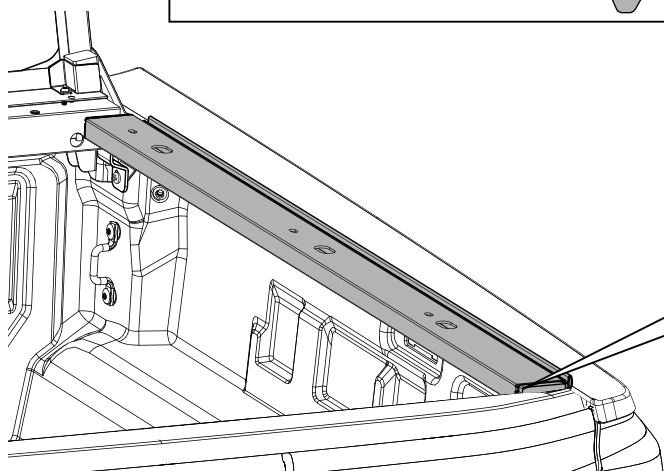
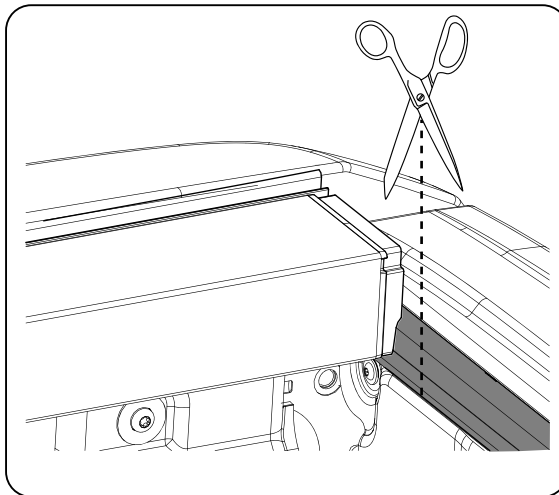
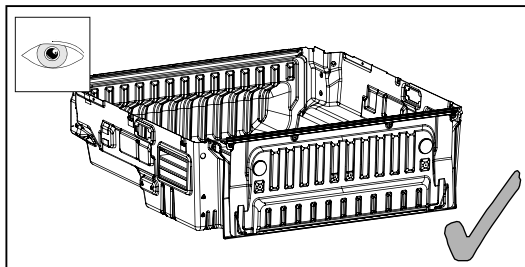

21

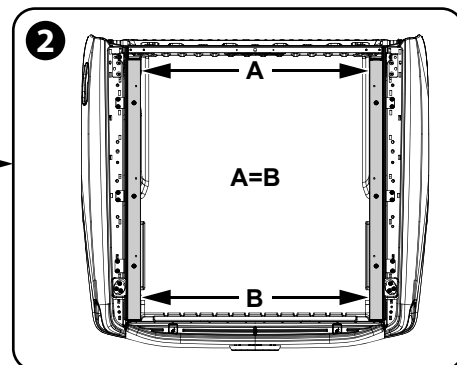
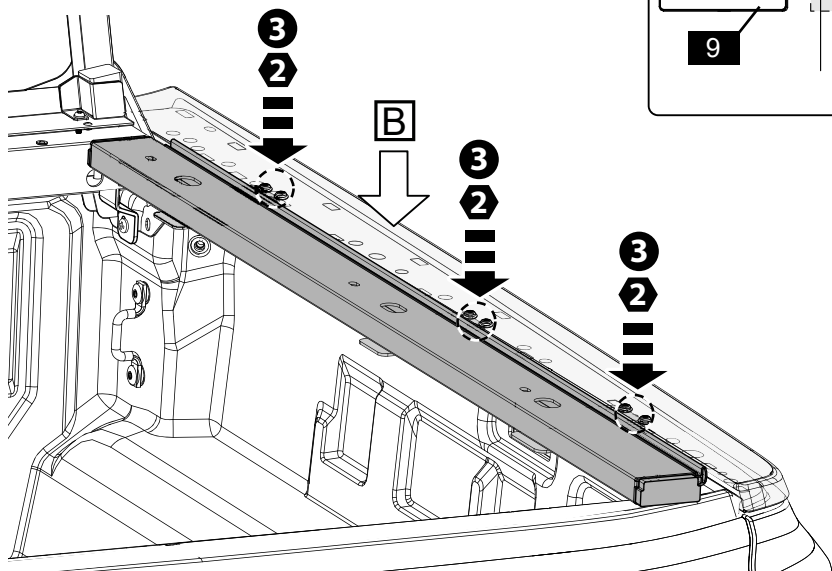
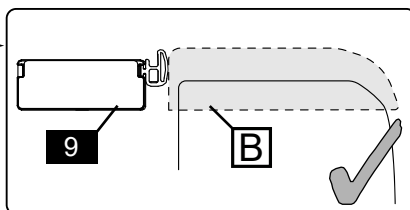
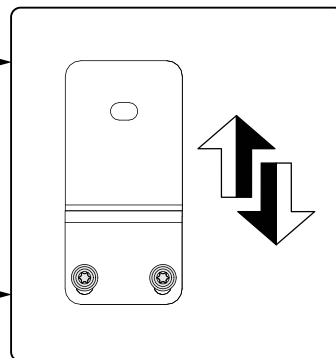
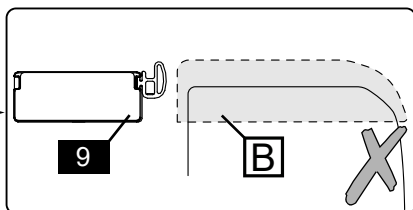
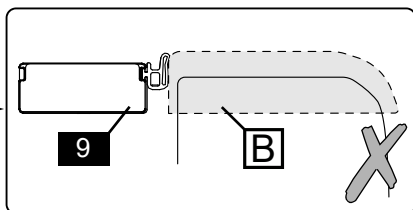
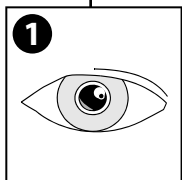
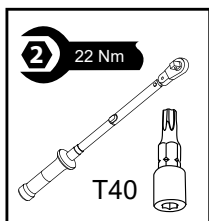

22

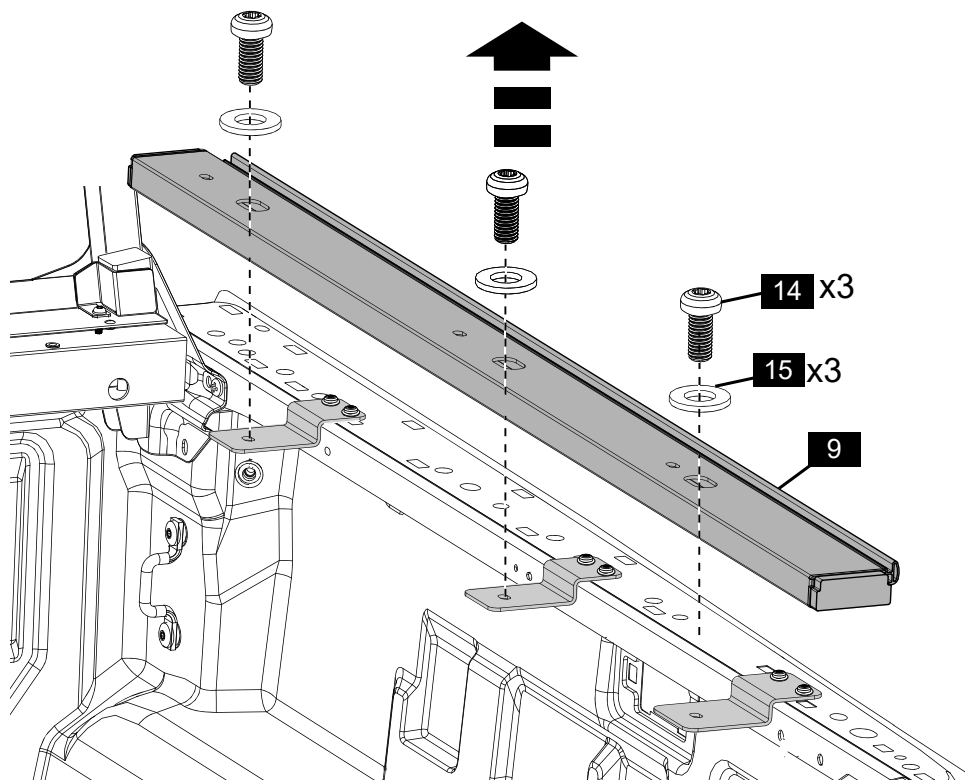
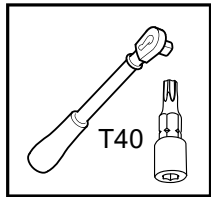

23

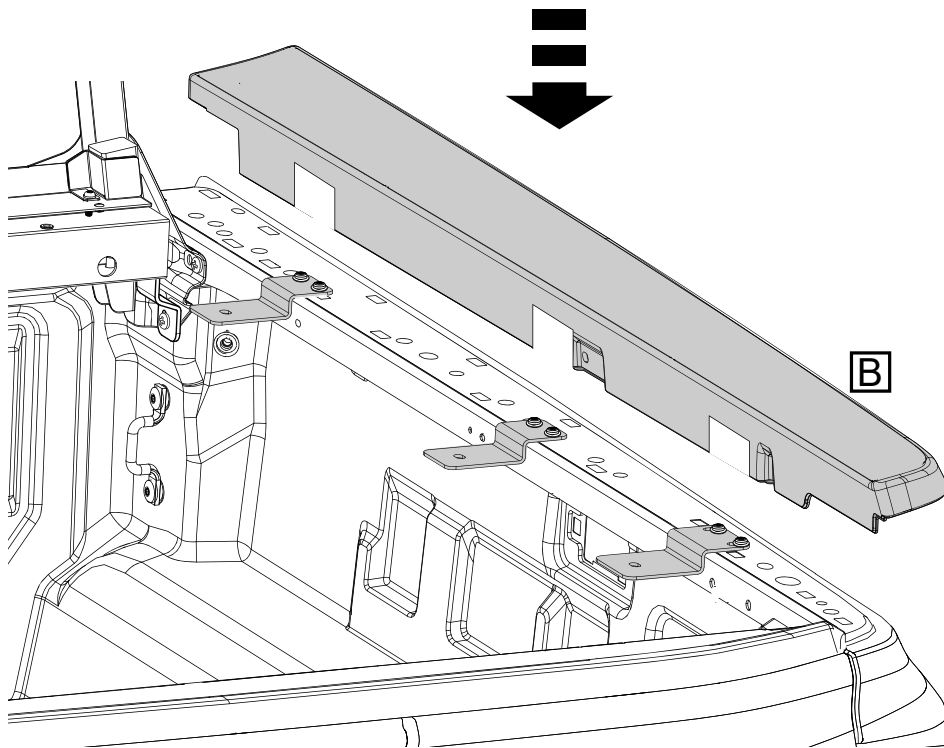

24

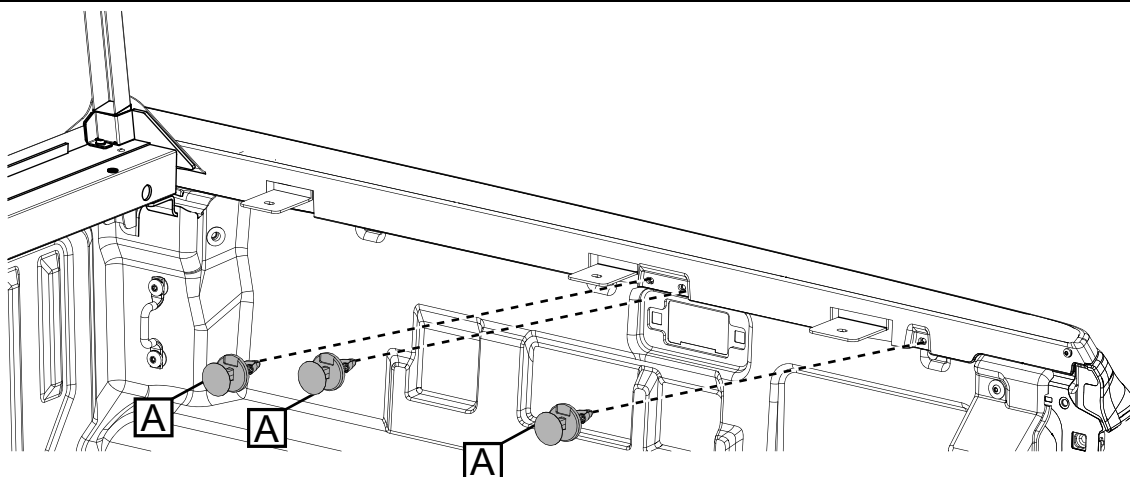

25

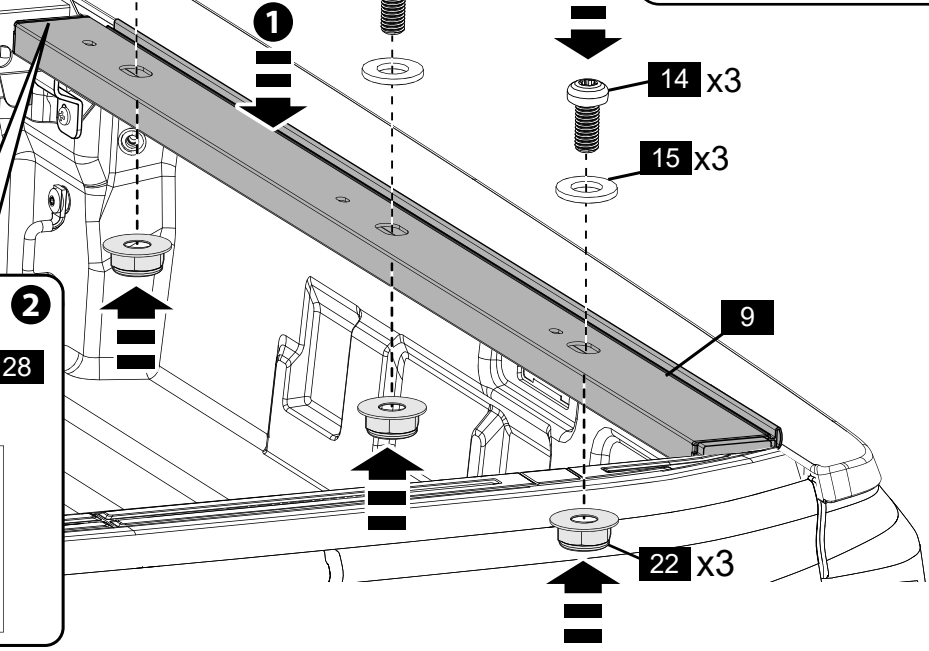
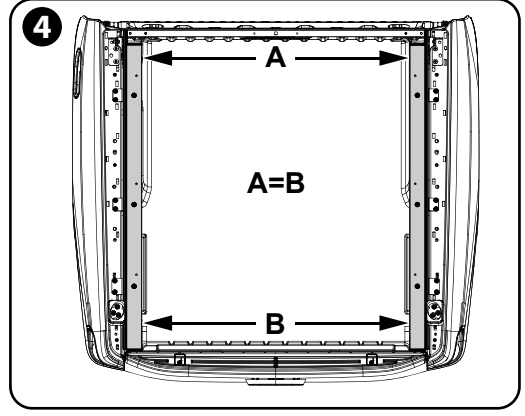
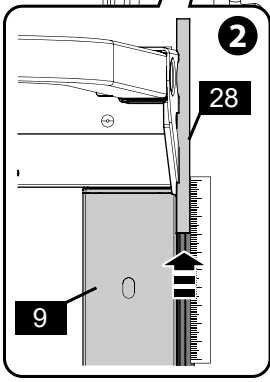
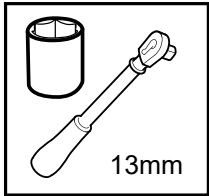
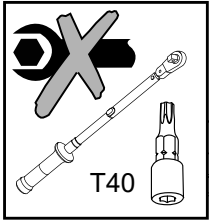
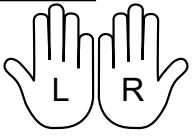

26

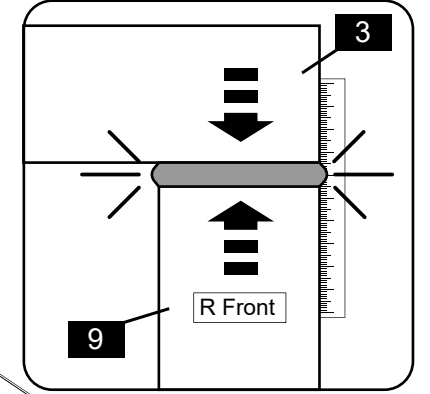
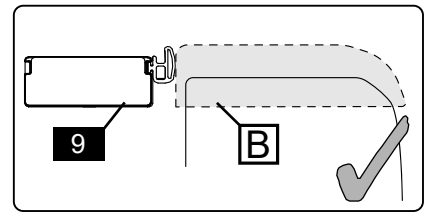
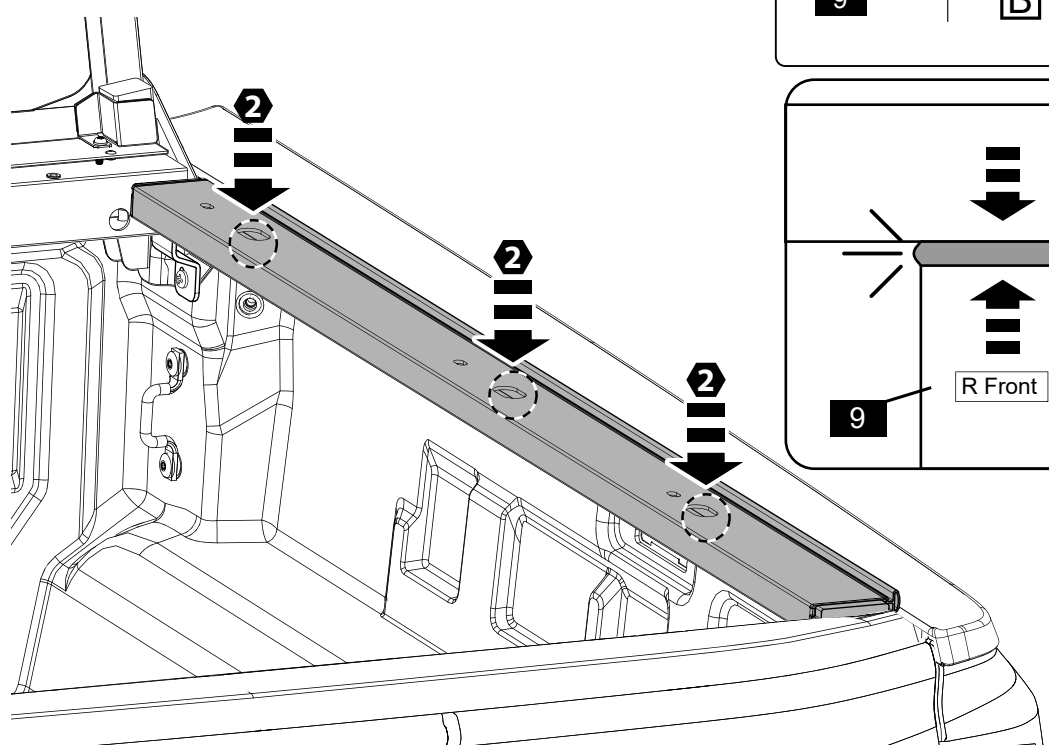
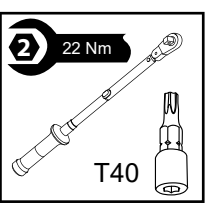

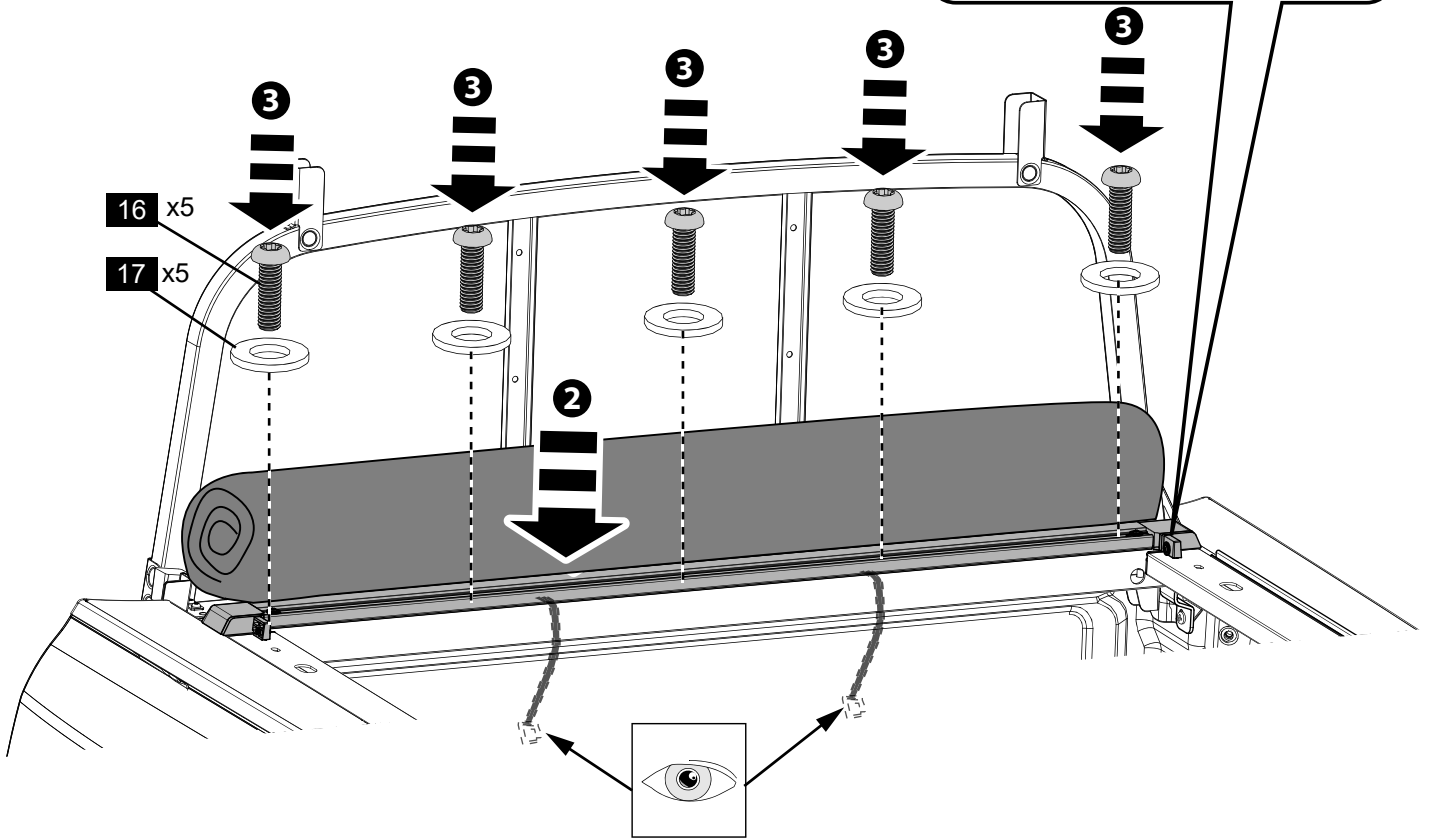
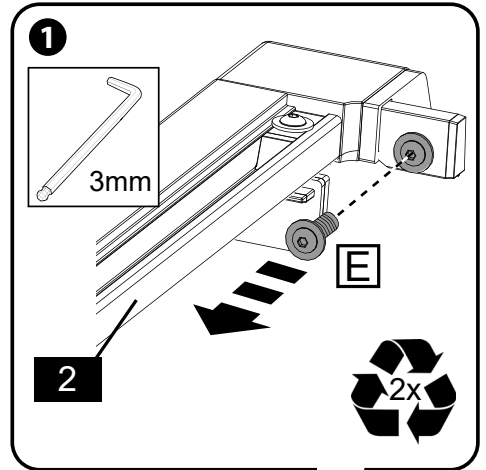
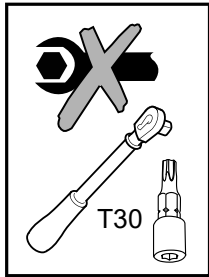

28

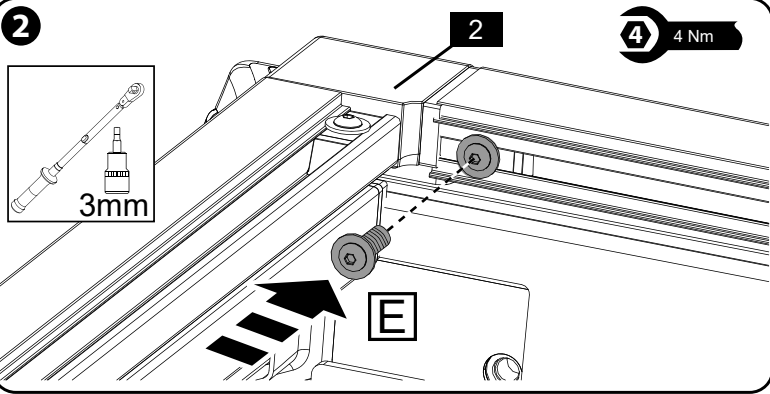
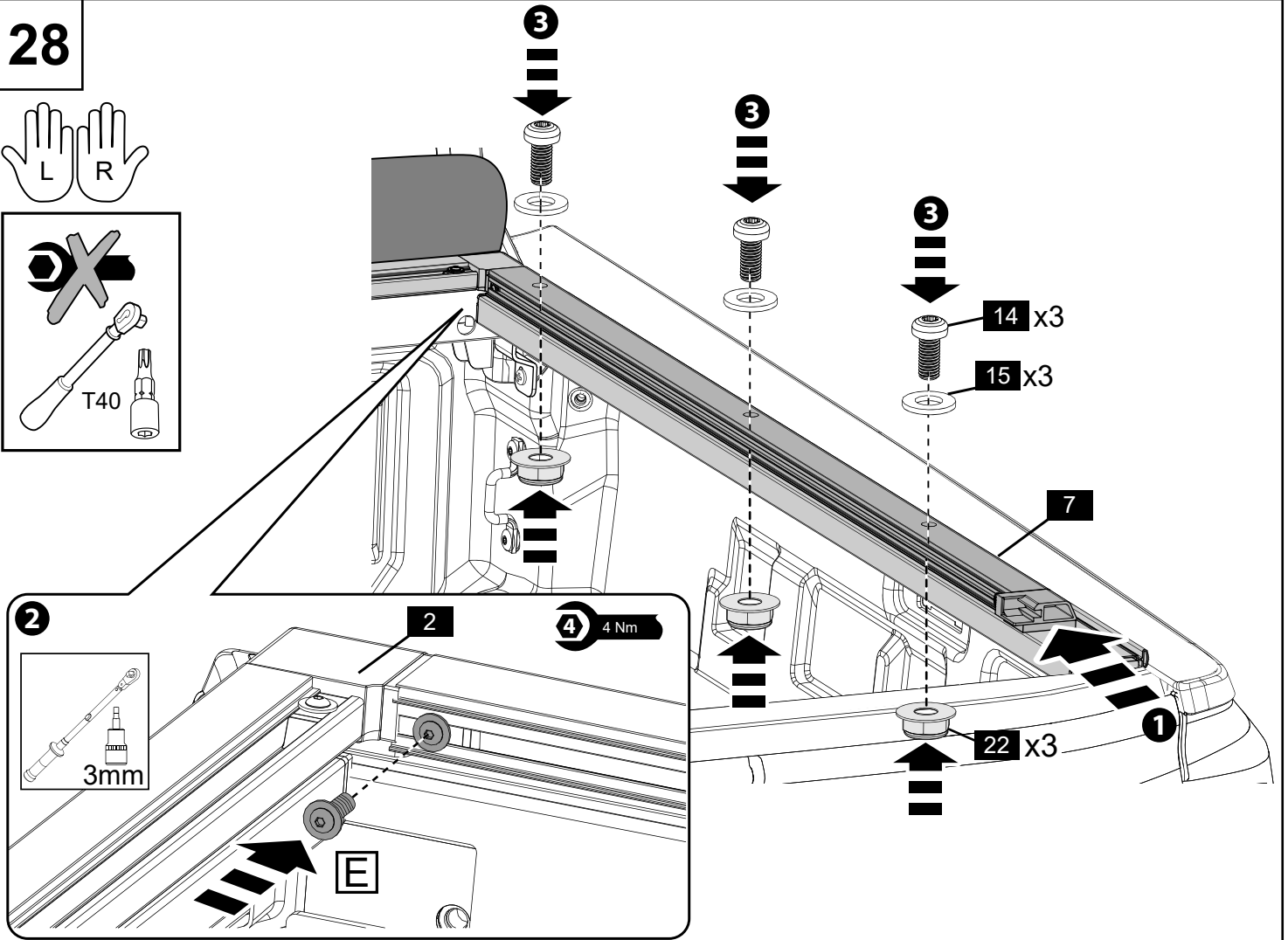
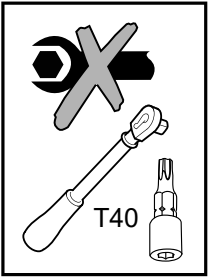

29

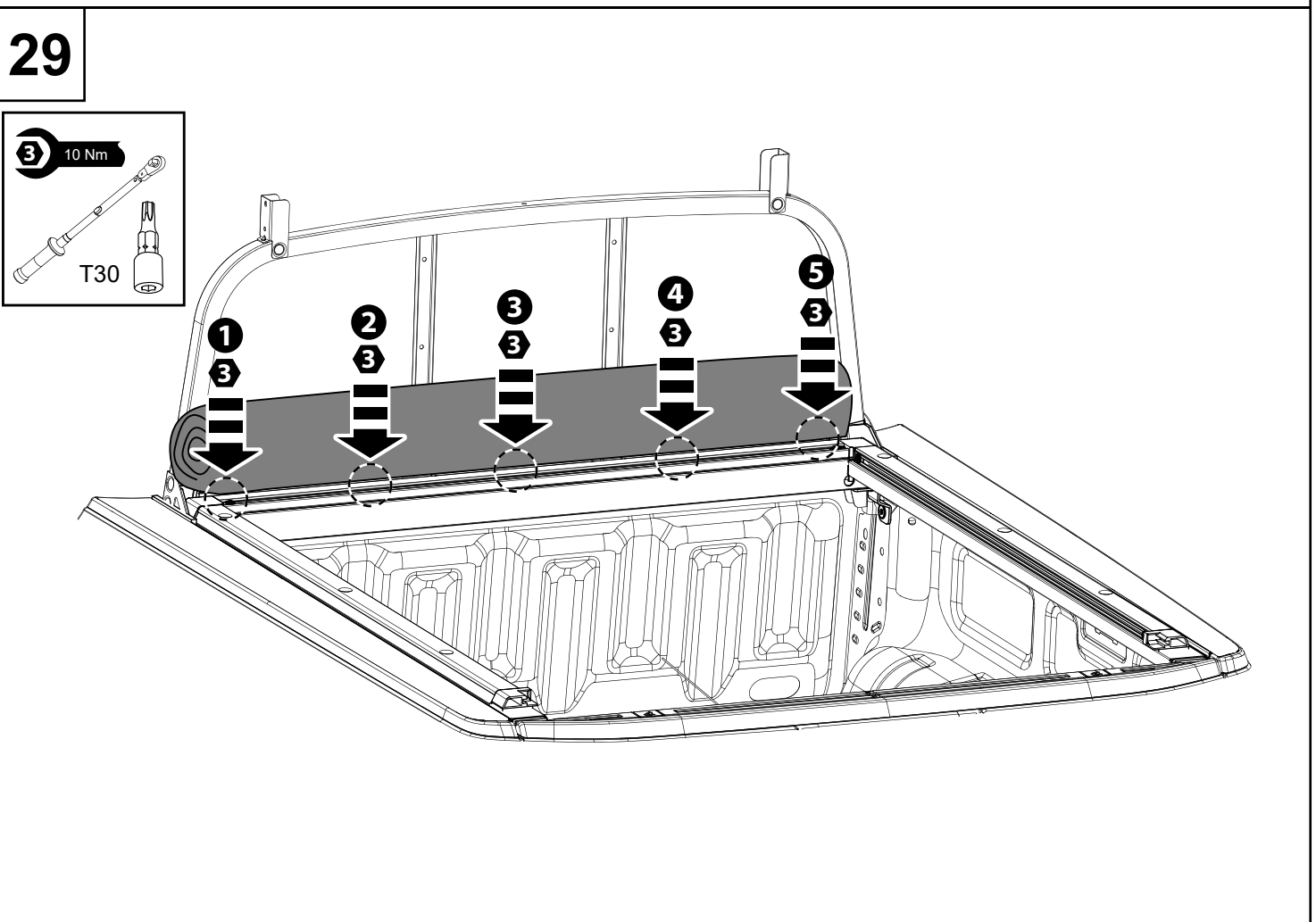
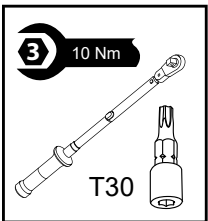

30

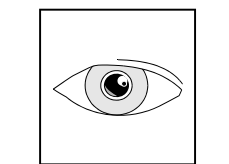
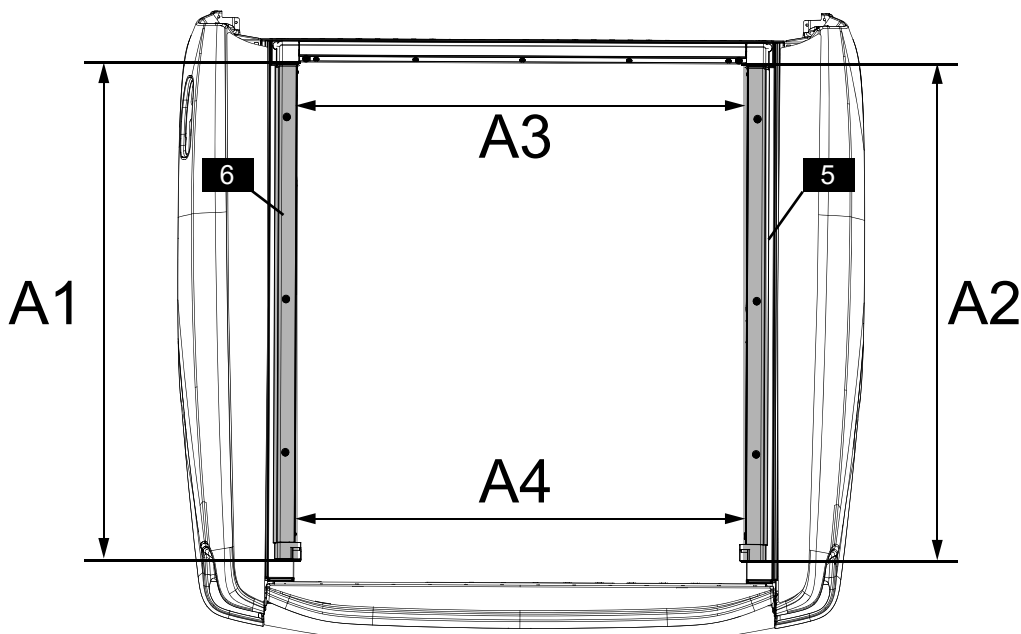
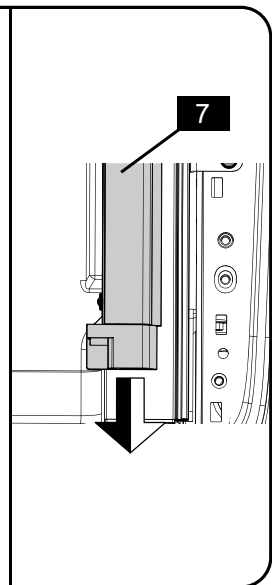
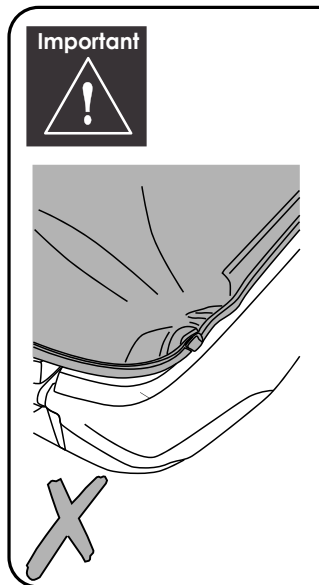
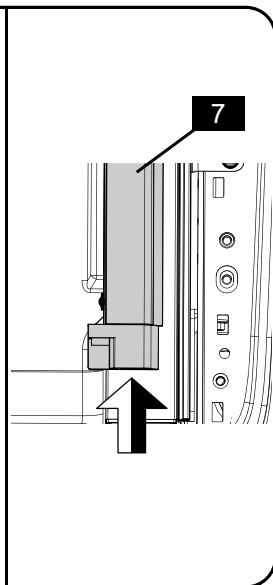
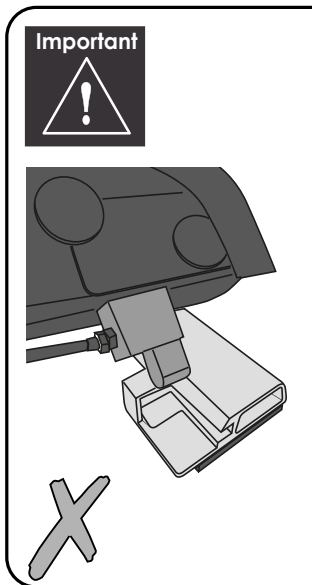
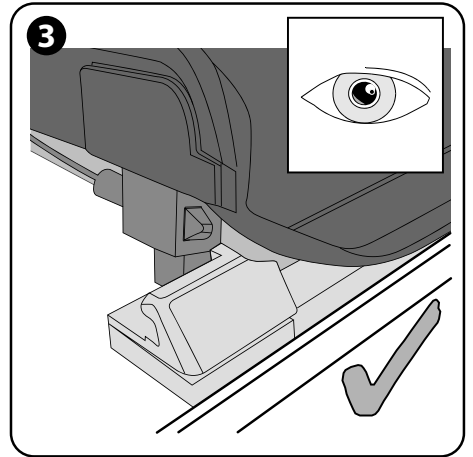
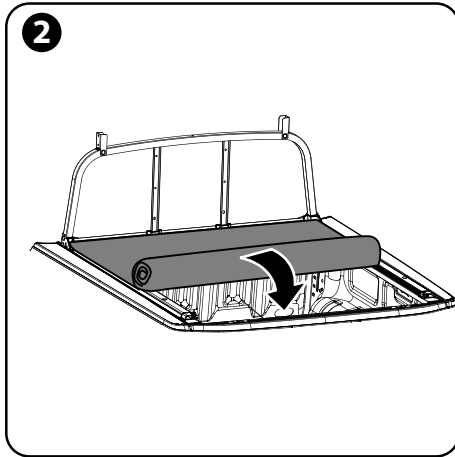
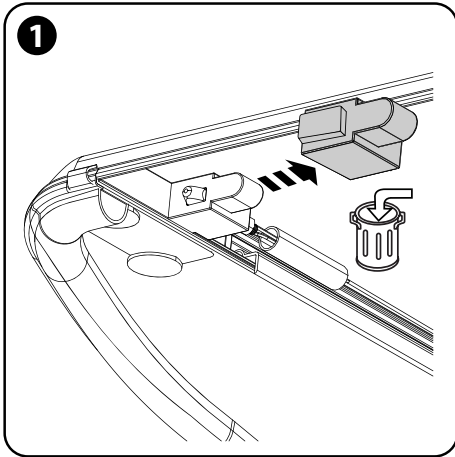
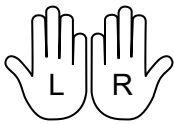

A1 = A2

A3 = A4

31

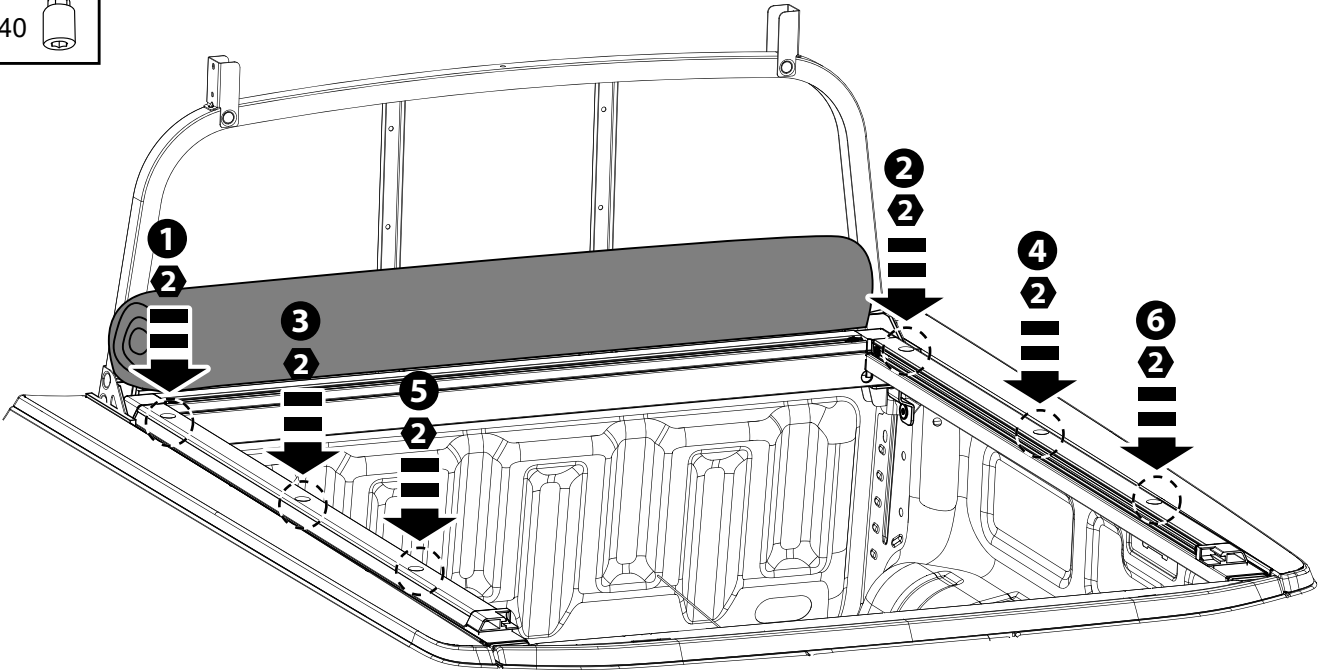
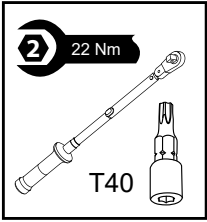

32

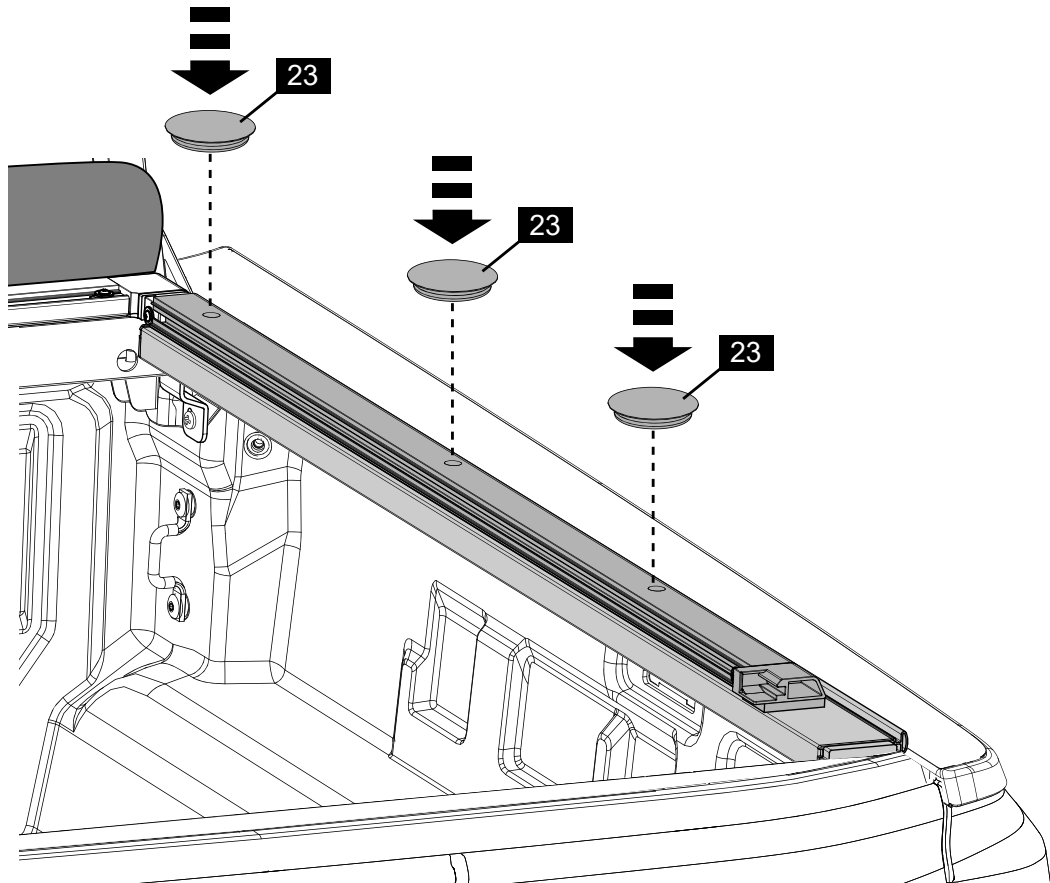

33

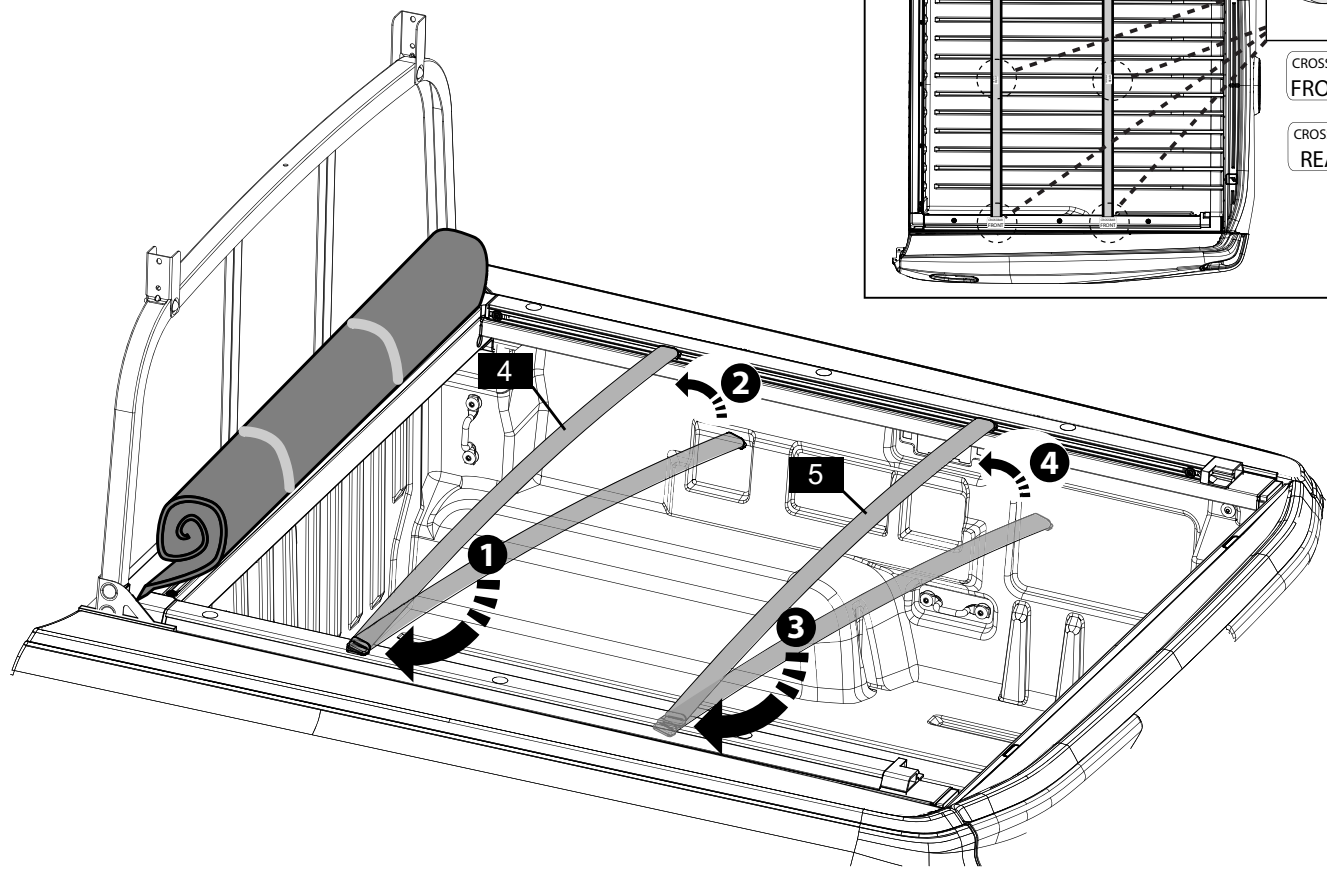
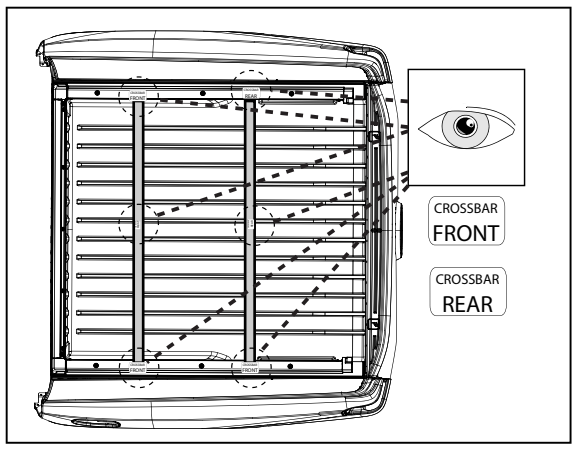

34

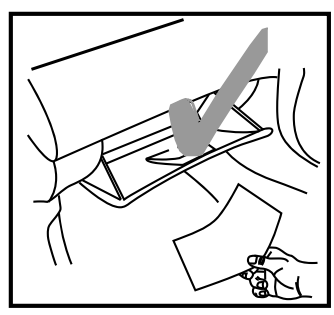
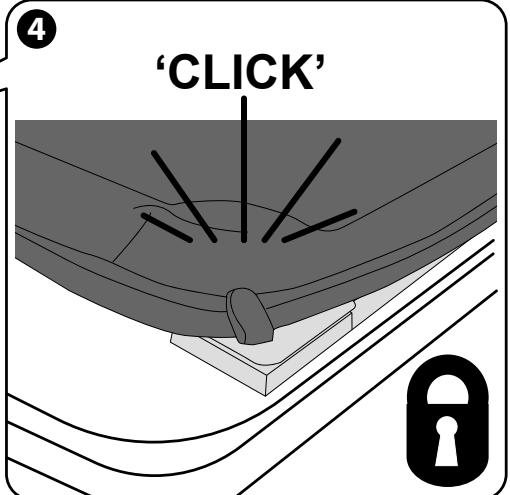
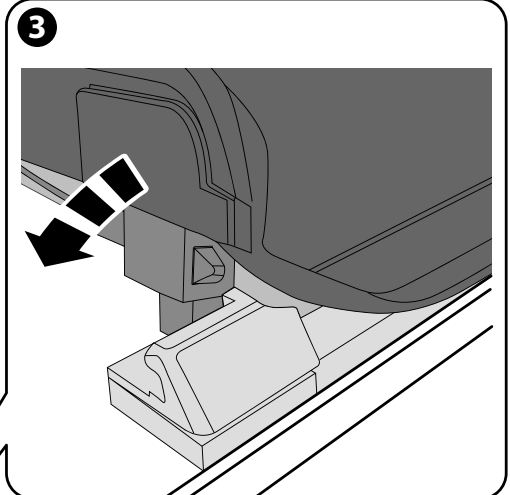
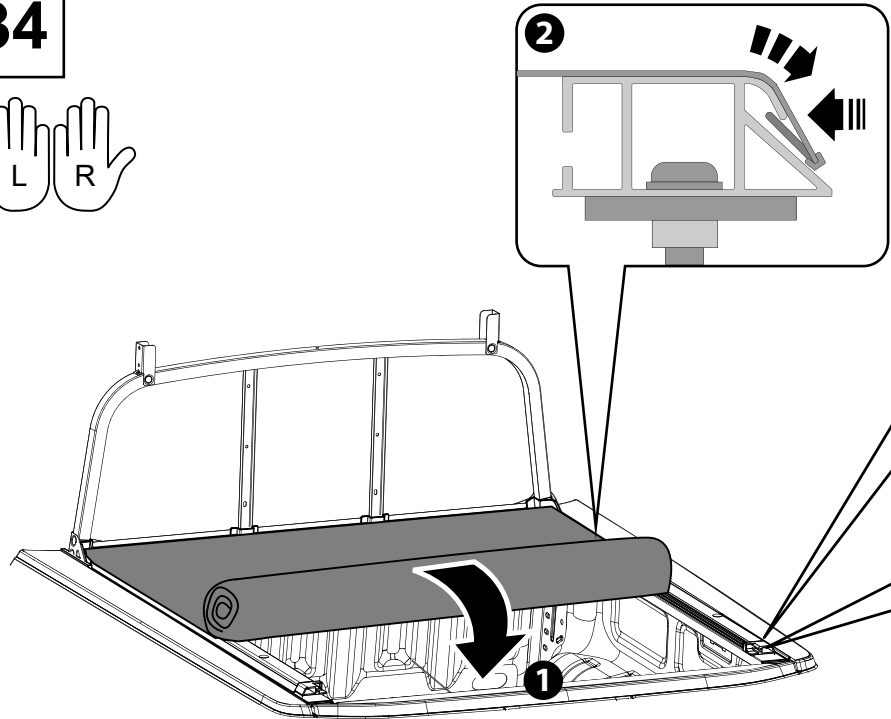
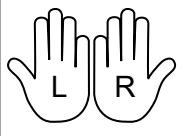

🔒 CLOSE

🔓 OPEN

