

VOLKSWAGEN AMAROK

1 PIECE HARD TONNEAU COVER

INSTALLATION INSTRUCTIONS

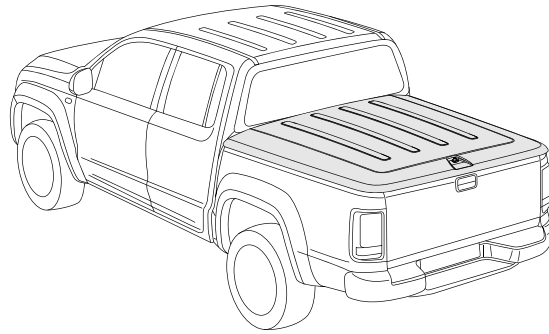

Care Instructions:



Clean Tonneau Cover with a mild detergent and water solution.



Do not use abrasive cleaners or solvents.



Place these instructions in vehicle's glove box after installation is complete

WARNING!

When in the closed position, Tonneau Cover must be latched and tailgate must be closed! Failure to do so could result in unexpected opening of the Tonneau Cover from sudden wind gusts, driving conditions, which could cause damage to the vehicle and/or your Tonneau Cover!

DO NOT close the Tailgate when the Hard Tonneau is in the closed position, as damage may occur to the vehicle and/or your Tonneau Cover!

MAINTENANCE:

Only use cleaners, waxes, or products that are labelled safe for use on plastics. Avoid the use of any chemicals to clean your Tonneau Cover unless labelled safe for plastics. Avoid use of abrasive type cleansers as they may dull the finish.

The gas struts are self lubricating and should only be cleaned occasionally with a damp cloth. Premature seal failure will result if solvents or lubricants are used to clean struts.

Gas struts must be connected with the cylinder (wide) end to the Tonneau Cover or Warranty is Void.

The locking mechanisms and latches only require occasional lubrication with Graphite Powder.

DO NOT use any other lubricants or oils. Using alternative products will VOID Warranty.

All installation hardware and fasteners must be checked every so often for tightness.

TONNEAU COVER - IMPORTANT:

- Read instructions carefully before installation. It is strongly recommended that installation is conducted by an authorized Volkswagen dealer.
- This product must be installed exactly as specified in these instructions. Failure to do so may result in improper fit and/or retention.
- Do not stand/sit or rest heavy objects on Tonneau Cover.
- Humans or animals are not to be under the closed Tonneau Cover at any time.
- Securely latch Tonneau Cover before operating vehicle.
- Do not carry open volatile chemicals with Tonneau Cover installed.
- If contact with volatile chemicals occurs clean Tonneau Cover with mild detergent and water solution.
- Recommend installation by 2 people.
- Fitting Instructions must be given to the end customer to understand correct removal and replacement process onto the vehicle.

PAINTING INSTRUCTIONS: (IF UNPAINTED)

- Prior to painting, clean all surfaces to be painted using clean water and a mild detergent, do not use lacquer thinner or any solvent based products. Wipe completely dry.
- Best results will be achieved by wiping the areas to be painted with a tack rag just prior to painting.
- Select a top coat and clear paint that is suitable for PC/ABS (Poly-Carbonate-Acrylonitrile-Butadiene-Styrene).
- Automotive paint systems, such as Acrylics or Two Packs, can be applied directly to the components. However, some paints may require a primer. If recommendations on paint specification are not followed, cracking of the part or degradation to the material may result. In all paint systems, aromatic hydrocarbons and alkalis are best avoided to reduce damage to the material properties.
- If using a paint system which requires baking, do not expose the product to temperatures above 70° C (155° F).
- Allow a minimum of 8 hours after baking before installation on the vehicle.

TOOLS REQUIRED:



- Fine Point Non Permanent Marker
- Hammer & Centre Punch
- Drill
- Ø3, Ø6 & Ø7mm Drill Bits
- Rivet Gun
- Phillips Screwdriver (No 3)
- Torque Wrench
- Spanners 10mm & 13mm
- Socket Set
- Tape Measure
- Masking Tape

VOLKSWAGEN AMAROK 1 PIECE HARD TONNEAU COVER







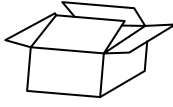



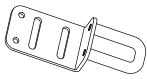

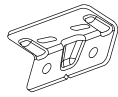
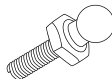

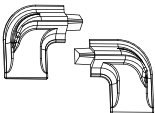
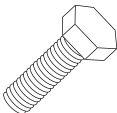
PARTS CHECK SHEET

VW AMAROK - 1 PIECE Hard Tonneau Cover

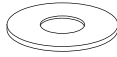
PARTS IN MAIN CARTON

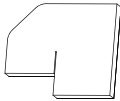
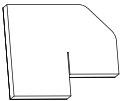
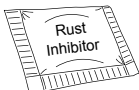
1	2	3
		
Tonneau Cover Qty - 1	Lock Keys (Attached to Tonneau) Qty - 2	Fitting Kit (KIT032127) Qty - 1

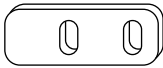
PARTS IN FITTING KIT (KIT032127)

3	4	5	6	7	8	
						
Latch Striker (LOCK0023) Qty - 2	Hinge Lower (CLIP1987-1) Qty - 2	Hinge Pin (CLIP2032) Qty - 2	Hinge Mount Bracket (CLIP2812PC) Qty - 2	Ball Stud Screw M6 (SCRW0724) Qty - 2	Gas Strut Standard (STRT0005-2) Qty - 2	
9	10	11	12	13	14	15
						
Corner Piece Moulding (INJM0012-1) Qty - 1 Pair	M8x20 Hex Head Bolt (SCRW0665) Qty - 4	M8 Flat Washer (WASH0171) Qty - 8	M8 Nyloc Nut (NUTS0242) Qty - 4	M6x16 Hex Head Bolt (SCRW0633) Qty - 8	M6 Flat Washer Large (WASH0169) Qty - 12	M6 Flat Washer Small (WASH0153) Qty - 8
16	17	18	19	20	21	22
						
M6 Nyloc Nut (NUTS0016) Qty - 10	LH-Tub Sealing Block (TAPE0618-LH) Qty - 1	RH-Tub Sealing Block (TAPE0618-RH) Qty - 1	Rust Inhibitor (MISC2776) Qty - 2	Alcohol Wipe (MISC0052) Qty - 4	Striker Plate (CLIP2771) Qty - 2	Fitting Instruction (FIT-TC0225c) Qty - 1

PARTS IN KIT (KIT032116)

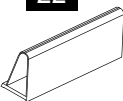
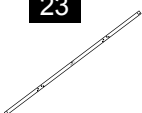
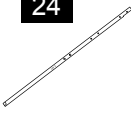
22	23	24
		
Header Rail Seal (MISC2229-2) Qty - 1	Front Drill Template (MISC3349) Qty - 1	Side Drill Template (MISC3321) Qty - 1

VOLKSWAGEN AMAROK 1 PIECE HARD TONNEAU COVER

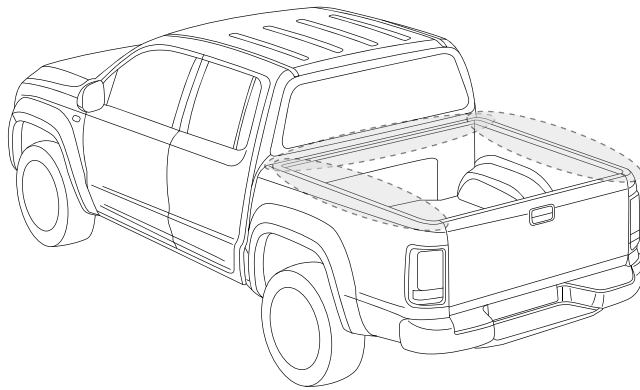

CLEAN & DRY
INSTALLATION AREAS

Diagram #:1

1. **NOTE: Two people are required to complete installation.**
Thoroughly clean and dry the installations areas. See Dia #1.

VIEWS LOOKING UP INTO LEFT HAND SIDE FRONT VEHICLE TUB CORNER

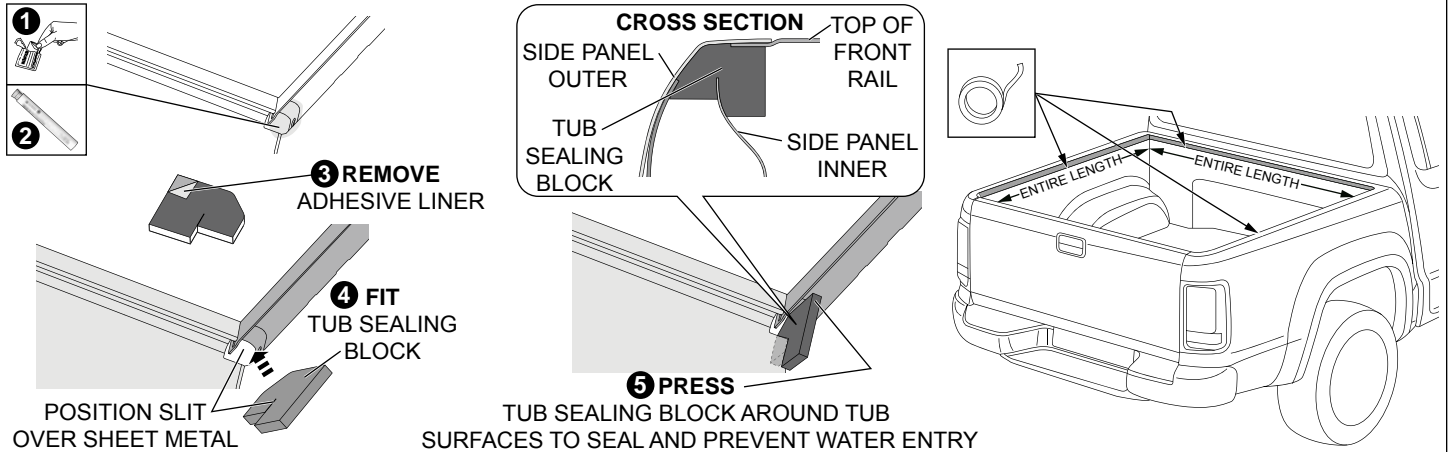

Diagram #:2

2. Using alcohol wipe provided clean the front inside corners of the tub and wipe away residue with a dry clean cloth. Remove adhesive liner from the left hand tub sealing block. Feed tub sealing block through the opening allowing the split to sit over the sheetmetal inner skin panel and firmly press into place as shown. Repeat process for the other side of the vehicle.
IMPORTANT: This step must be done properly to assist water sealing.
Place masking tape in sections along the entire length of the front and side rails as shown. See Dia #2.

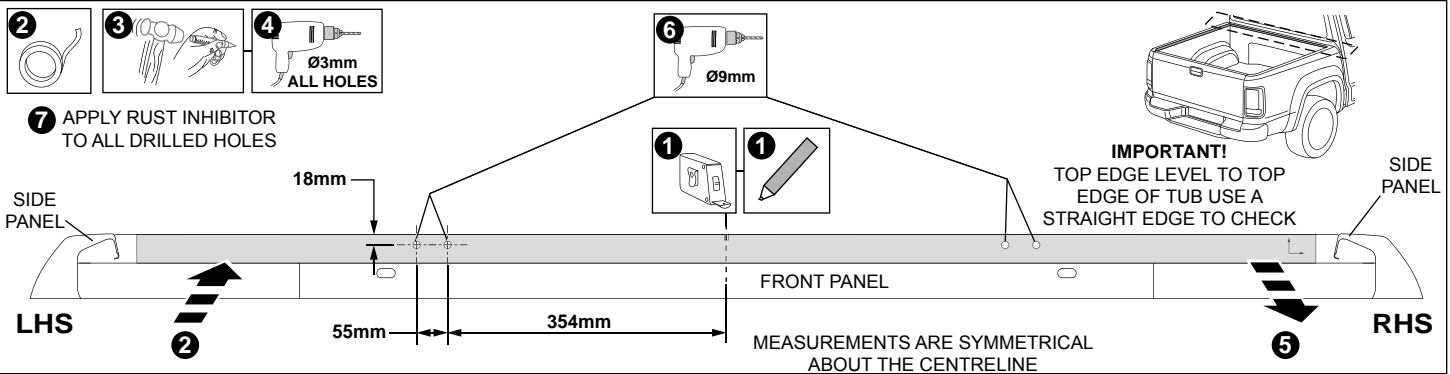

Diagram #:3

3. Measure and mark a centreline on the tub front panel. Align front drill template to marked centreline, ensuring arrows are facing up and top edge is level to top of front panel. Attach using masking tape. If a drill template is unavailable, measure and mark hole centres as dimensioned above. Centrepunch all hole positions and drill all four (4) holes with Ø3 pilot drill and remove the drill template. Drill the four (4) holes to Ø9mm as shown. Remove masking tape from the front rail. Remove all burrs, sharp edges and swarf from vehicle. Apply rust inhibitor to all drilled holes. See Dia #3.

VOLKSWAGEN AMAROK 1 PIECE HARD TONNEAU COVER

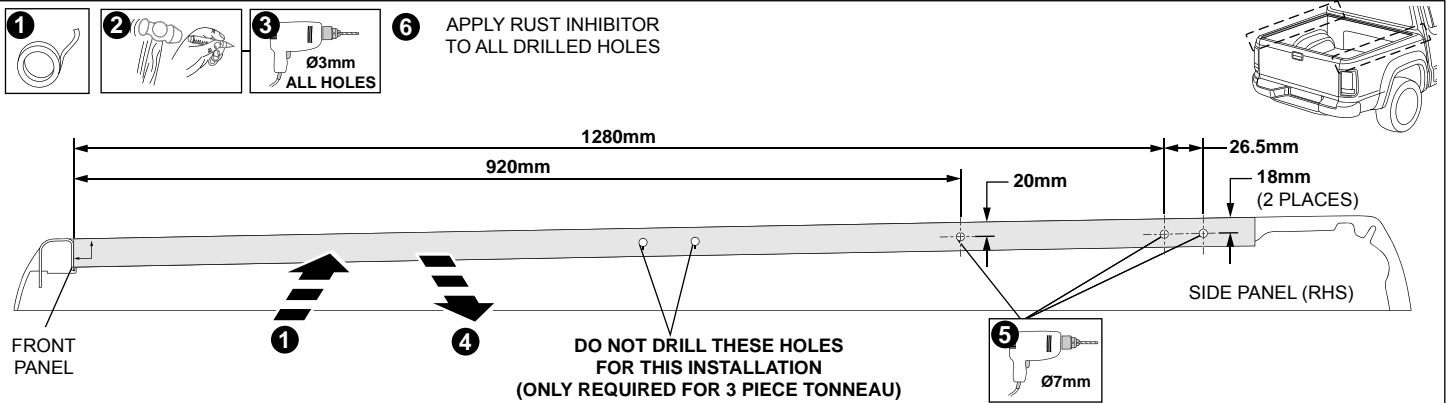

Diagram #4

4. Position the side drill template flush to the front panel as shown, ensuring arrows are facing up and to the front of the vehicle, and top edge is level with top of side rail. Attach using masking tape. If a drill template is unavailable, measure and mark hole centres as dimensioned above for both sides of the vehicle. Centrepunch all required hole positions. **Do not mark or drill the front two (2) holes as noted above.** Drill all holes with $\text{\O}3$ pilot drill and remove the drill template. Drill all holes $\text{\O}7$ as shown. Repeat process by reversing the template to use on the other side of the vehicle. Remove all masking tape from the side rails. Remove all burrs, sharp edges and swarf from vehicle. Apply rust inhibitor to all drilled holes. **See Dia #4.**

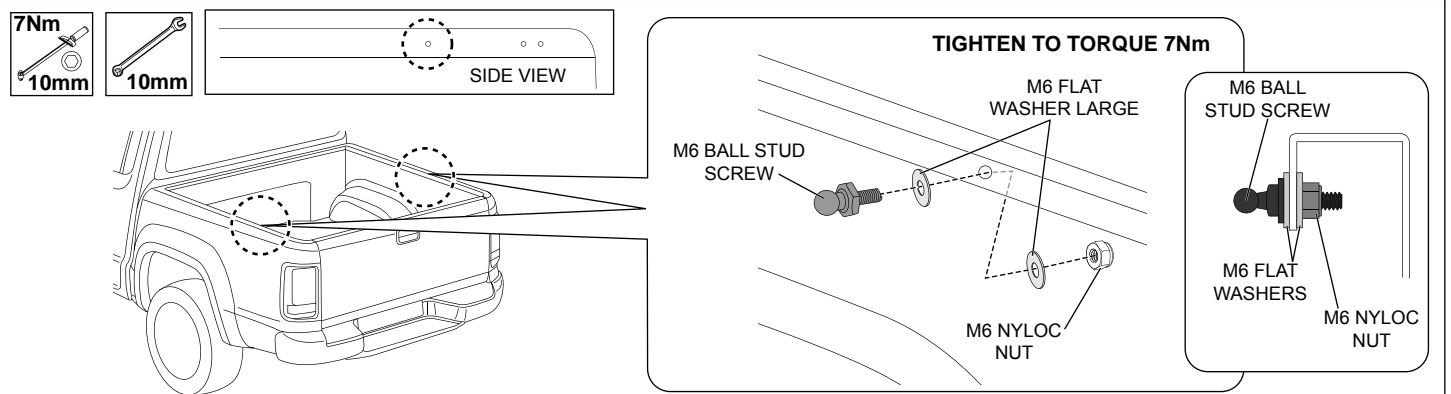

Diagram #5

5. Fit the M6 ball stud screw to the side rail and secure with two (2) M6 flat washers large and one (1) M6 nyloc nut as shown. **Tighten to Torque 7Nm.** Repeat process for the other side of the vehicle. **See Dia #5.**

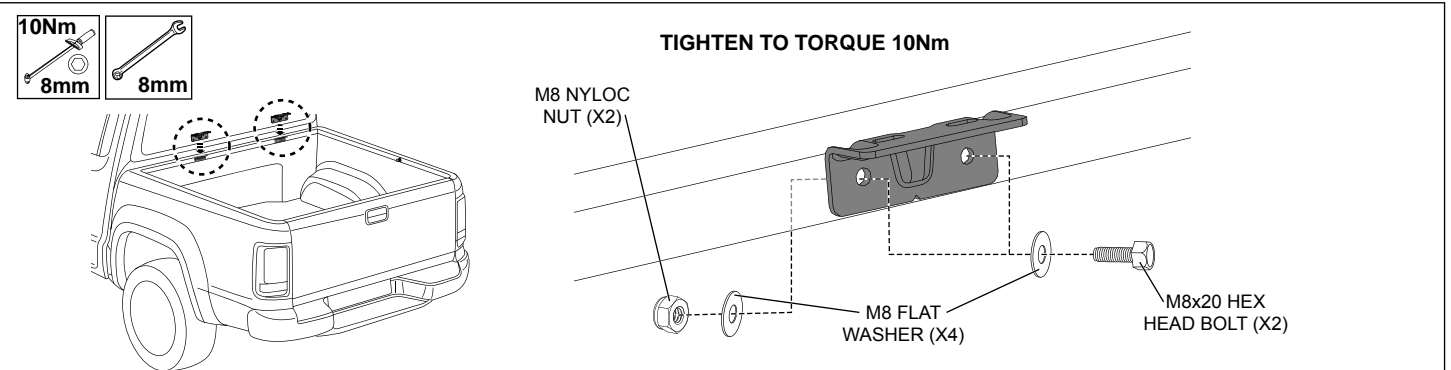

Diagram #6

6. Orient hinge mount bracket as shown and align the holes with the $\text{\O}9$ mm holes previously drilled in the front panel. Secure hinge mount bracket with two (2) M8x20 hex head bolts, four (8) M8 flat washers and two (2) M8 nyloc nuts as shown. **Tighten to Torque 10Nm.** Repeat process for the other side of the vehicle. **See Dia #6.**

VOLKSWAGEN AMAROK 1 PIECE HARD TONNEAU COVER

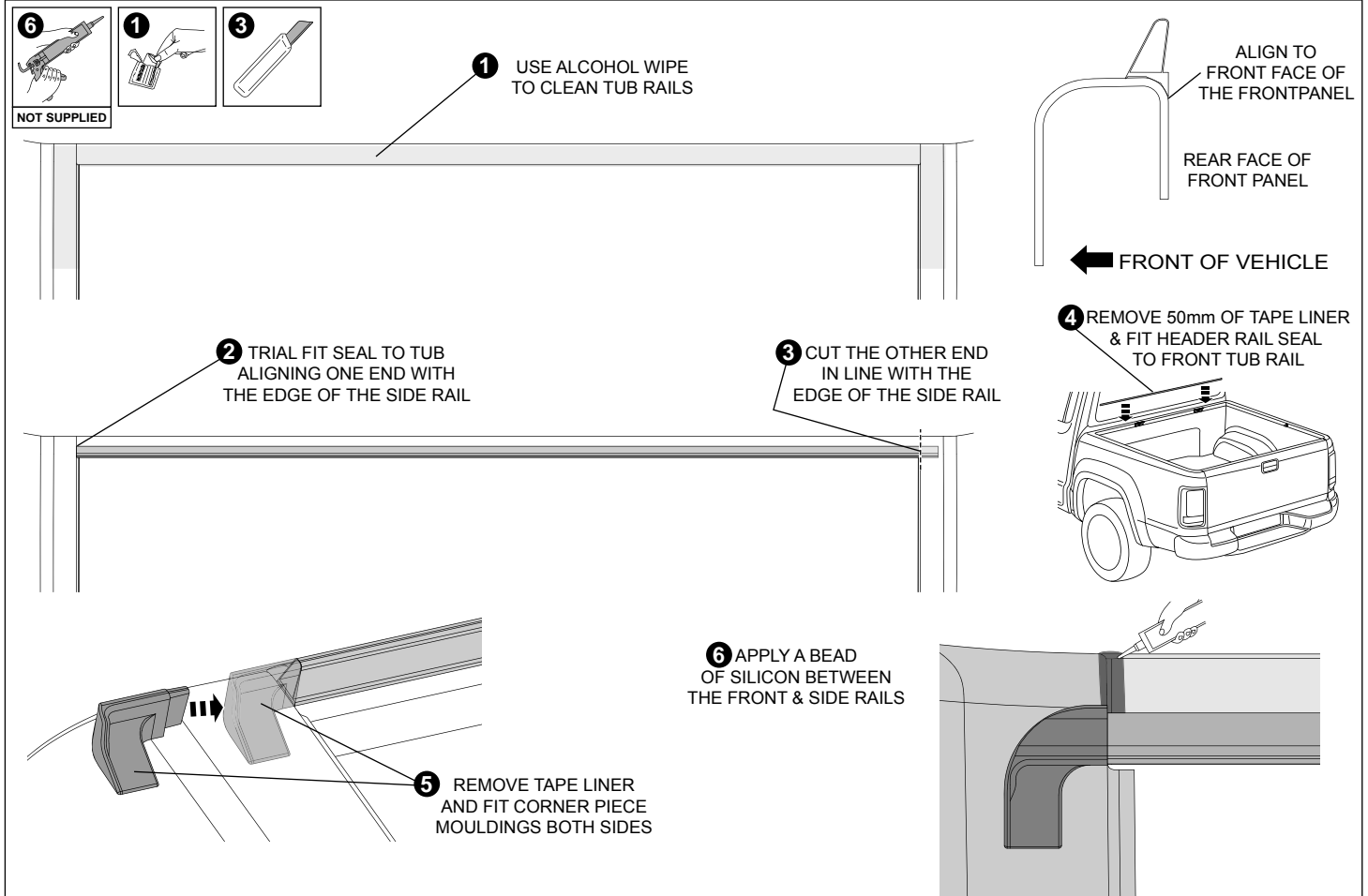

Diagram #:7

7. Using alcohol wipe provided, clean the front and side rails of the tub as shown and wipe away residue with a dry clean cloth. Trial fit header rail seal to the tub (ensuring it is oriented correctly as shown), aligning one end with the edge of the side rail and cut the other end in line with the edge of the side rail as shown. Remove approximately 50mm length from one end of liner. Orient and align edge of seal with edge of side rail and rearward edge of seal with the rear face of the front panel as shown. Starting from one end apply light pressure and remove liner along the length of the seal, ensuring seal runs parallel with the edge of the front panel. Remove tape liner from corner piece moulding and fit into header rail seal and apply firm pressure down onto side rail as shown. Repeat process for the other side of the vehicle. Re-apply firm pressure along the full length of the header rail seal ensuring it is fully adhered to the tub. Apply a bead of silicon to the front of the tub between the front & side rails as shown. **See Dia #7.**

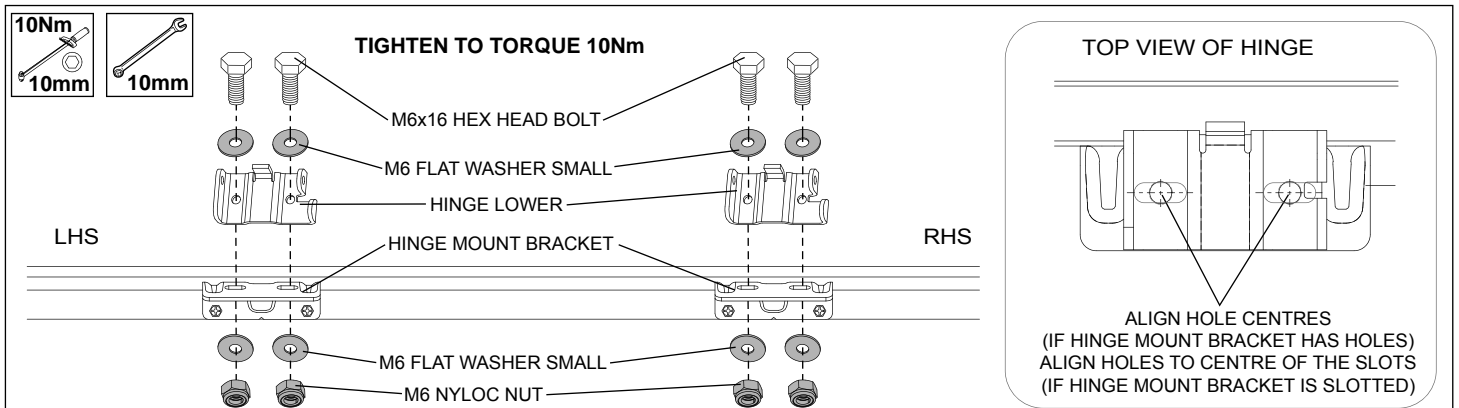

Diagram #:8

8. Orient the two (2) lower hinges as shown. **NOTE: The the hinge mount bracket may have slots or holes.** Align the holes in the hinge lower with the holes in the hinge mount brackets (if hinge mount bracket has holes), as shown, or align the holes in the hinge lower with the centre of the slots in the hinge mount brackets (if hinge mount bracket is slotted), as shown. Secure with two (2) M6x16 hex head bolts, four (4) M6 flat washers small and two (2) M6 nyloc nuts for each hinge as shown. **Tighten to Torque 10Nm. See Dia #8.**

VOLKSWAGEN AMAROK 1 PIECE HARD TONNEAU COVER

IMPORTANT: Ensure vehicles's tailgate is opened before installing Tonneau Cover, and remains open until lock striker is fitted and locking mechanism is adjusted correctly. **DO NOT** close the Tailgate when the Hard Tonneau is in the closed position, as damage may occur to the vehicle and/or your Tonneau Cover!

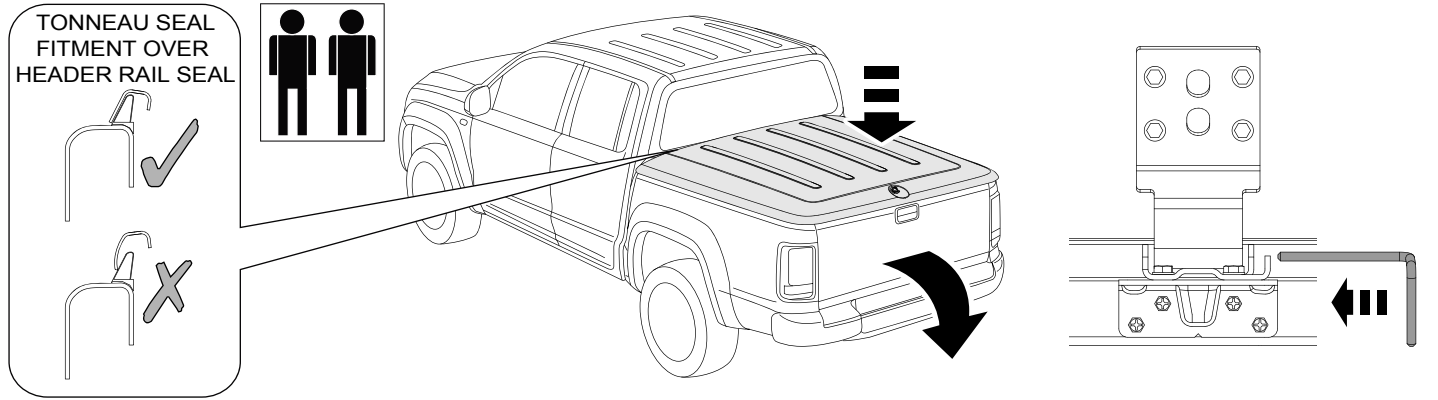

Diagram #:9

9. Open vehicle's tailgate and keep it open until locking mechanism has been adjusted correctly. Two people are required to carry out the fitment of the tonneau cover. Carefully fit tonneau cover to vehicle ensuring seal at the front of the tonneau cover sits correctly over the header rail seal as shown. Secure hinges with hinge pins as shown. **See Dia #9.**
IMPORTANT: Ensure hinge pins clip into retaining leg on lower hinges. If misaligned, seal can be pushed forward from inside of the tub.

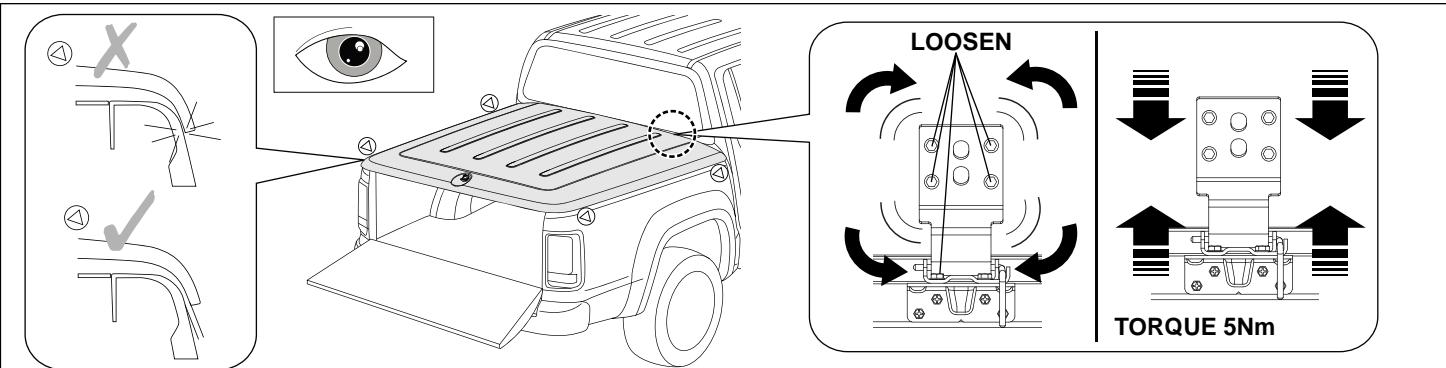

Diagram #:10

10. With tailgate open, Close and check Tonneau Cover is central to vehicle and the sides of Tonneau Cover do not contact the vehicle bedrail. Adjust position if necessary by loosening the top hinge screws for fore and aft adjustment and hinge mount screws for side to side adjustment to re-position Tonneau Cover to fit centrally on vehicle. Re-tighten hinges to **Torque 5Nm**. **See Dia #10.**

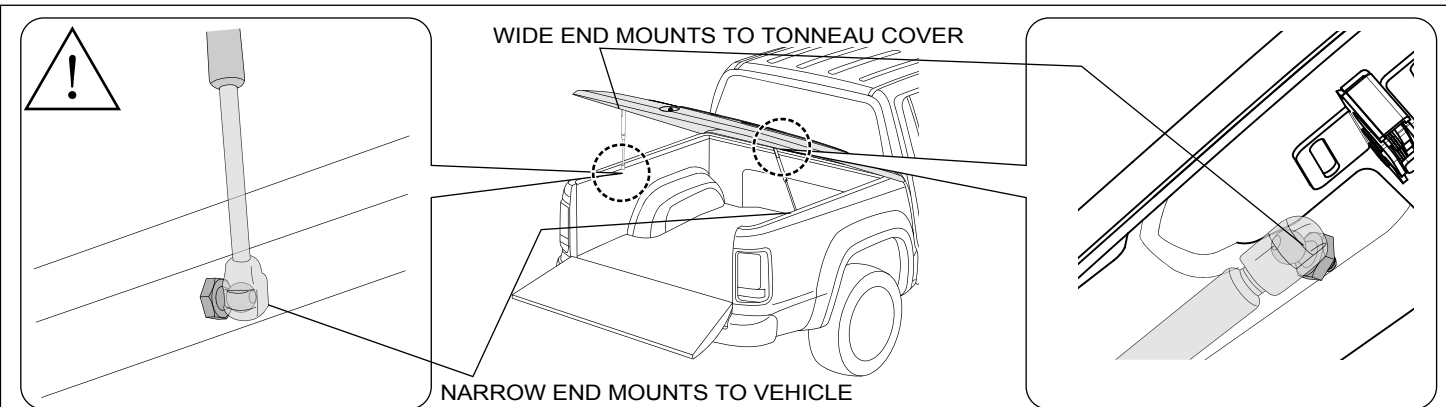

Diagram #:11

11. Attach gas struts by clipping into place as shown. Ensure the narrow end mounts to the vehicle and the wide end mounts to the tonneau cover. **See Dia #11.**
!! Failure to do so Voids Warranty on gas struts!!

VOLKSWAGEN AMAROK 1 PIECE HARD TONNEAU COVER

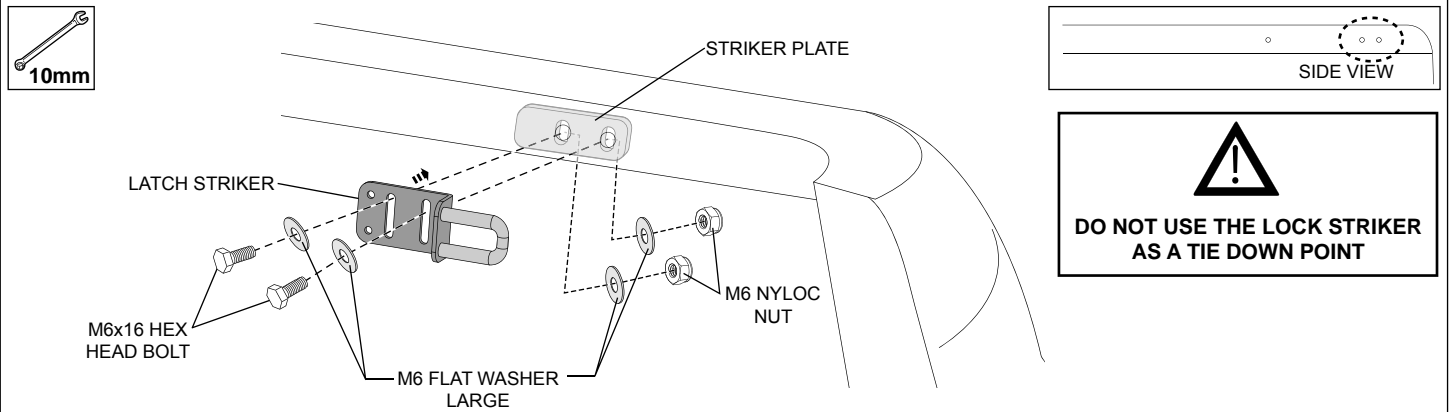

Diagram #:12

12. With the tailgate open, fit the latch striker, to the rear of the side rail and striker plate to the inside of the tub. Secure with two (2) M6x16 hex head screws, four (4) M6 flat washers large and two (2) M6 nyloc nuts as shown. **Do not fully tighten at this stage.** Repeat process for other side of the vehicle. See Dia #12.

IMPORTANT: Ensure vehicles's tailgate is opened and remains open. Tonneau could lock during adjustment process.

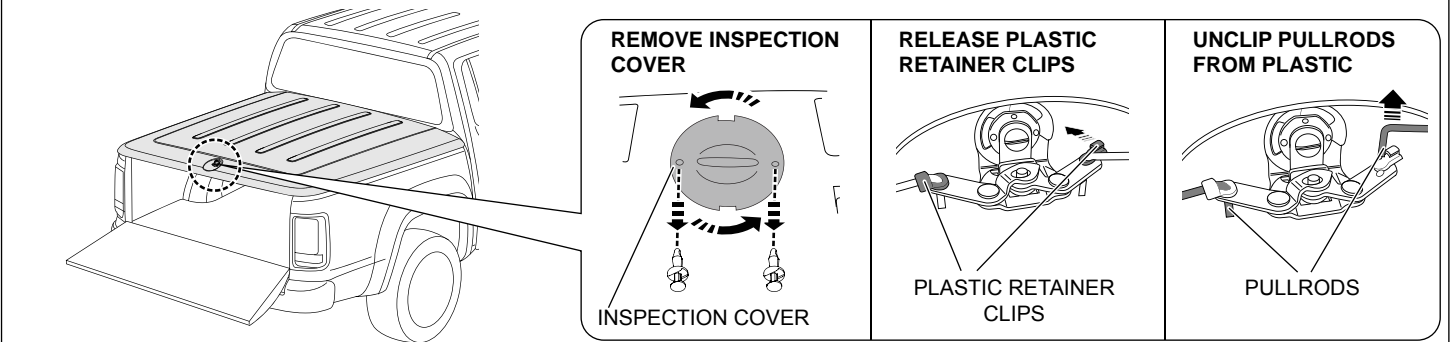

Diagram #:13

13. Open Tonneau Cover and remove inspection cover by removing scrivenets and rotating cover anti-clockwise. Release plastic retainer clips and unclip pullrods as shown. See Dia #13. **IMPORTANT: TAILGATE MUST BE OPEN TONNEAU COULD LOCK DURING ADJUSTMENT PROCESS.**

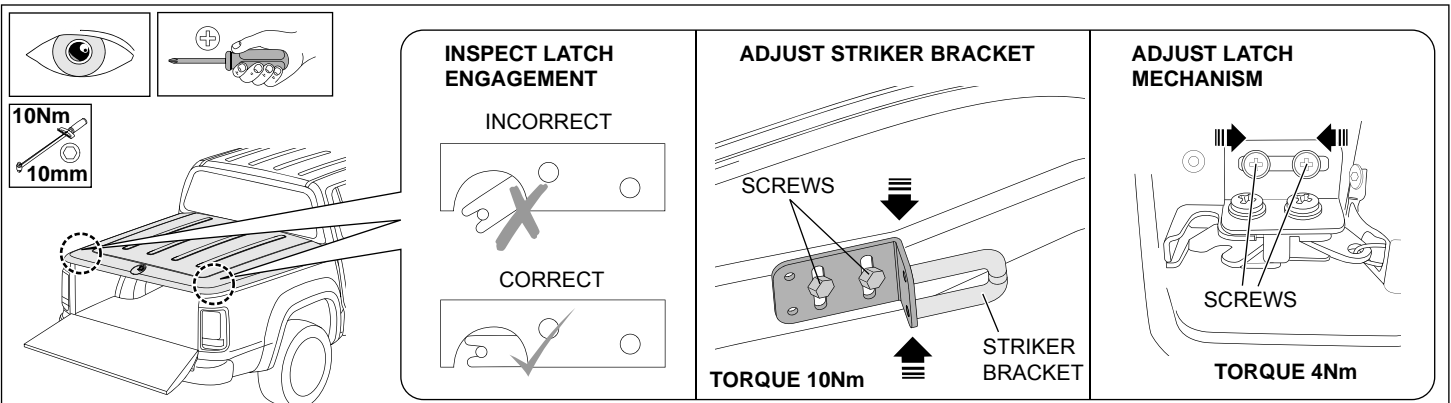

Diagram #:14

14. Close Tonneau Cover and inspect locking mechanism. Ensure the latch hits the striker bracket centrally. If it **DOES NOT**, adjust the latch accordingly by loosening the screws and moving the latch left or right as shown. Tighten to **torque 5Nm**. Adjust the height of the lock striker bracket by moving it up or down as shown. Tighten screws to **torque 10Nm**. See Dia #14. **Note: Tonneau Cover has 2 stage locks as a safety feature. Ensure Tonneau engages with second stage of the latch.**

VOLKSWAGEN AMAROK 1 PIECE HARD TONNEAU COVER

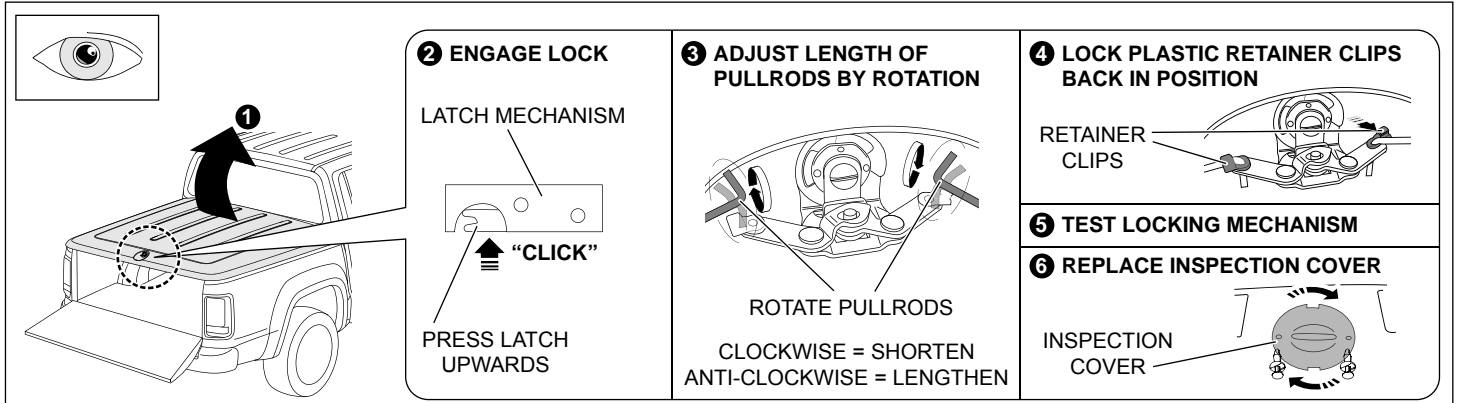

Diagram #:15

15. Open the Tonneau Cover and engage the lock by pressing upwards on the latch. Adjust pullrods so that they clip back into the retainer clips correctly. Do this by rotating them clockwise to shorten them or anti-clockwise to lengthen them (via internal turn buckle). Clip pullrods and retainer clips back into position. Test lock by pressing the button on top of Tonneau Cover. If latch mechanism **DOES NOT** release, return to **Step 3** and shorten the pullrods. If it **DOES** release, replace inspection cover. **See Dia #15.**

! IMPORTANT: Ensure that the Tonneau Cover locking mechanism is functioning correctly before closing tailgate.

CONTINUED OVER THE PAGE

VOLKSWAGEN AMAROK 1 PIECE HARD TONNEAU COVER

REMOVAL OF TONNEAU COVER

TWO PEOPLE ARE REQUIRED TO CARRY OUT THE REMOVAL OF THE TONNEAU COVER.

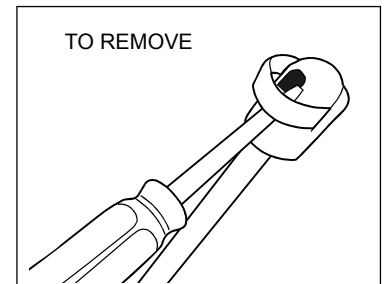
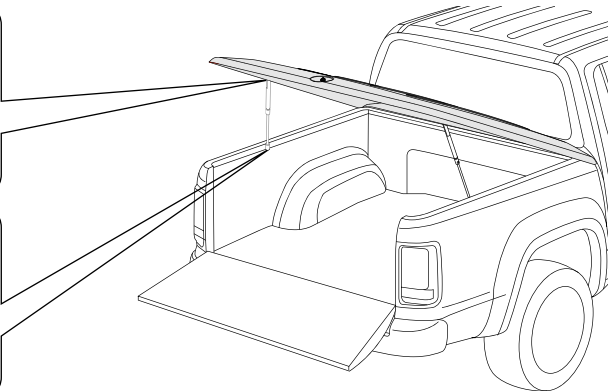
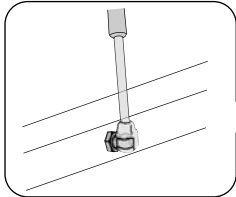
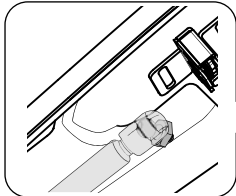
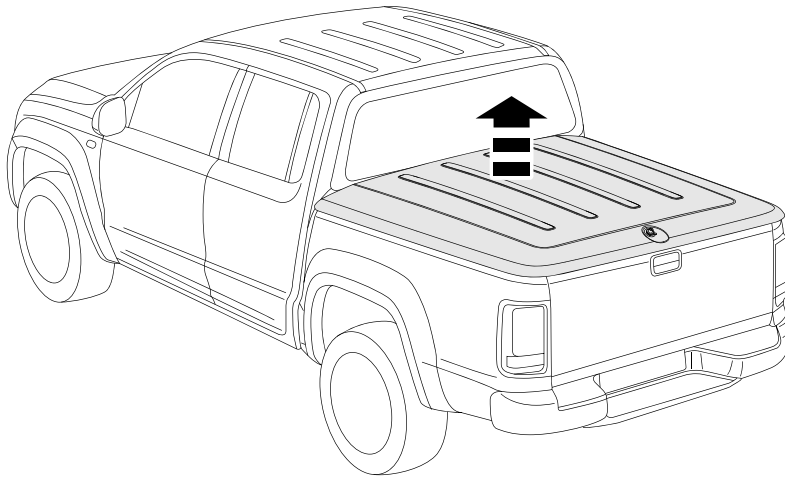

Diagram #:1

1. Detach gas struts by inserting a small screw driver and adjusting the spring clip on the strut. **See Dia #1.**
NOTE: Do Not remove the spring clip only a small amount of levering is required to detach.
Do Not remove without using a tool, damage can occur and Void Warranty.

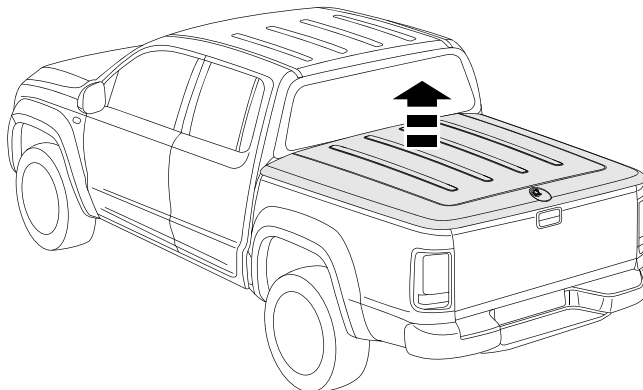
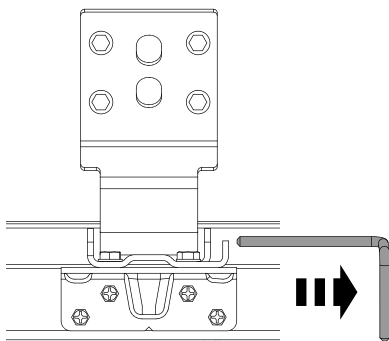

Diagram #:2

2. Remove hinge pins and then remove the Tonneau Cover. **See Dia #2.**

VOLKSWAGEN AMAROK 1 PIECE HARD TONNEAU COVER

RE-INSTALLATION OF TONNEAU COVER

TWO PEOPLE ARE REQUIRED TO CARRY OUT THE RE-INSTALLATION OF THE TONNEAU COVER.

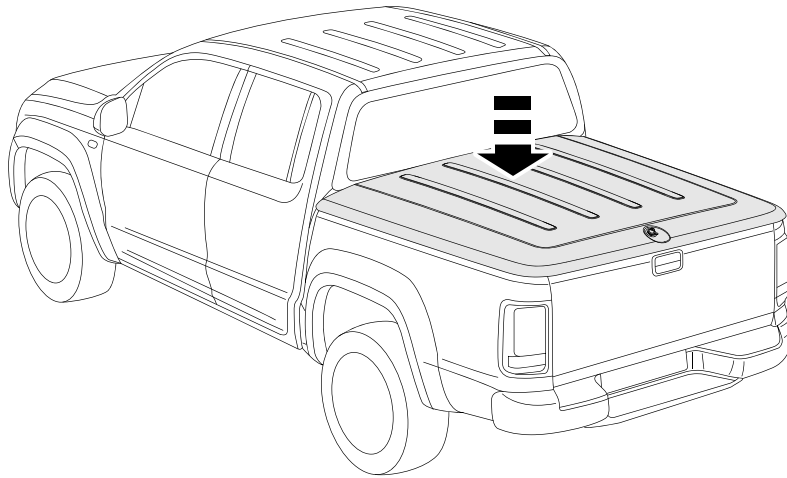

TONNEAU SEAL
FITMENT OVER
HEADER RAIL SEAL

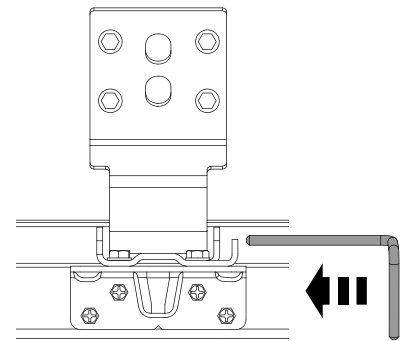
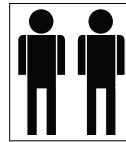
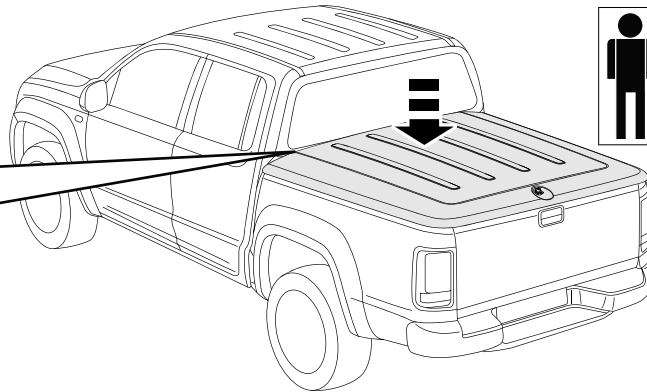
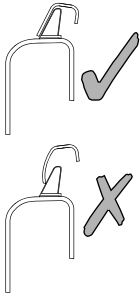
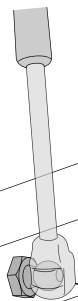
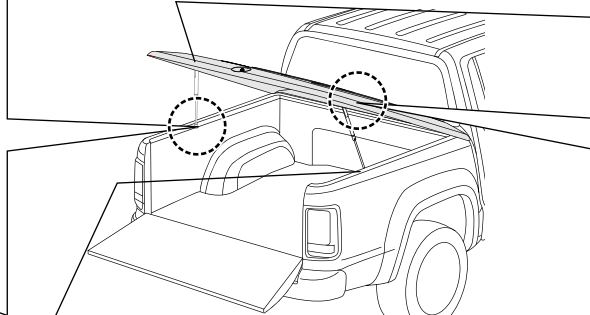

Diagram #:1

1. Open vehicle's tailgate and fit tonneau cover to vehicle ensuring seal at the front of the tonneau cover sits correctly over the header rail seal as shown. Secure hinges with hinge pins as shown. **See Dia #1.**
IMPORTANT: Ensure hinge pins snap into retaining clip mounted to the lower hinges.



WIDE END MOUNTS TO TONNEAU COVER



NARROW END MOUNTS TO VEHICLE

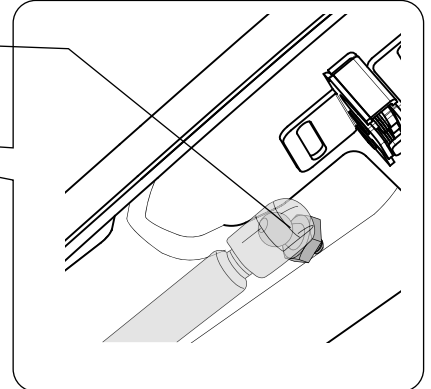

Diagram #:2

2. Attach gas struts by clipping into place as shown. **Ensure the narrow end mounts to the vehicle and the wide end mounts to the tonneau cover. See Dia #2.**
!! Failure to do so Voids Warranty on gas struts!!