

# MAZDA BT-50

(October 2011 Production Onwards)  
**3 PIECE HARD TONNEAU COVER  
 INSTALLATION INSTRUCTIONS**

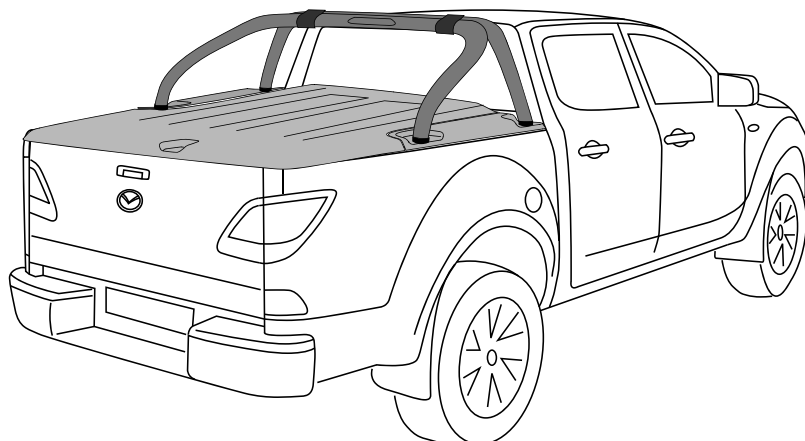

Installation Time: Approx . 120 Minutes

#### Care Instructions:



Clean Tonneau Cover with a mild detergent and water solution.



Do not use abrasive cleaners or solvents.



**Place these instructions in vehicle's glove box after installation is complete**

### WARNING!

When in the closed position, Tonneau Cover must be latched and tailgate must be closed! Failure to do so could result in unexpected opening of the Tonneau Cover from sudden wind gusts, driving conditions, which could cause damage to the vehicle and/or your Tonneau Cover!

DO NOT close the Tailgate when the Hard Tonneau is in the closed position, as damage may occur to the vehicle and/or your Tonneau Cover!

### MAINTENANCE:

Only use cleaners, waxes, or products that are labelled safe for use on plastics. Avoid the use of any chemicals to clean your Tonneau Cover unless labelled safe for plastics. Avoid use of abrasive type cleansers as they may dull the finish.

The gas struts are self lubricating and should only be cleaned occasionally with a damp cloth. Premature seal failure will result if solvents or lubricants are used to clean struts.

Gas struts must be connected with the cylinder (wide) end to the Tonneau Cover or Warranty is Void.

The locking mechanisms and latches only require occasional lubrication with Graphite Powder.

DO NOT use any other lubricants or oils. Using alternative products will VOID Warranty.

All installation hardware and fasteners must be checked every so often for tightness.

### TONNEAU COVER - IMPORTANT:

- Read instructions carefully before installation. It is strongly recommended that installation is conducted by an authorized Mazda dealer.
- This product must be installed exactly as specified in these instructions. Failure to do so may result in improper fit and/or retention.
- Do not stand/sit or rest heavy objects on Tonneau Cover.
- Humans or animals are not to be under the closed Tonneau Cover at any time.
- Securely latch Tonneau Cover before operating vehicle.
- Do not carry open volatile chemicals with Tonneau Cover installed.
- If contact with volatile chemicals occurs clean Tonneau Cover with mild detergent and water solution.
- Recommend installation by 2 people.
- Fitting Instructions must be given to the end customer to understand correct removal and replacement process onto the vehicle.







### PAINTING INSTRUCTIONS: (IF UNPAINTED)

- Prior to painting, clean all surfaces to be painted using clean water and a mild detergent, do not use lacquer thinner or any solvent based products. Wipe completely dry.
- Best results will be achieved by wiping the areas to be painted with a tack rag just prior to painting.
- Select a top coat and clear paint that is suitable for PC/ABS (Poly-Carbonate-Acrylonitrile-Butadiene-Styrene).
- Automotive paint systems, such as Acrylics or Two Packs, can be applied directly to the components. However, some paints may require a primer. If recommendations on paint specification are not followed, cracking of the part or degradation to the material may result. In all paint systems, aromatic hydrocarbons and alkalis are best avoided to reduce damage to the material properties.
- If using a paint system which requires baking, do not expose the product to temperatures above 70° C (155° F).
- Allow a minimum of 8 hours after baking before installation on the vehicle.

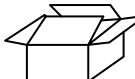

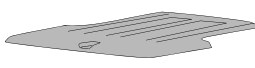

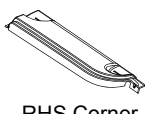





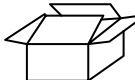
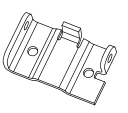
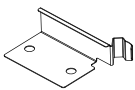



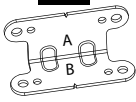







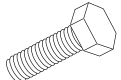





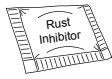
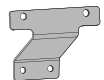

MAZDA BT-50 - 3 PIECE HARD TONNEAU COVER

PARTS CHECK SHEET

**PARTS IN MAIN CARTON**

	<b>1</b>	<b>2</b>	<b>3</b>	<b>4</b>	
					
	Tonneau Cover Qty - 1	LHS Corner Piece Qty - 1	RHS Corner Piece Qty - 1	Lock Keys Qty - 2	Fitting Kit (KIT032961) Qty - 1

**PARTS IN FITTING KIT**

	<b>5</b>	<b>6</b>	<b>7</b>	<b>8</b>	<b>9</b>	<b>10</b>	<b>11</b>	<b>12</b>
								
	Hinge Lower (CLIP2720PC) Qty - 2	Hinge Pin Retainer (CLIP2717-1) Qty - 2	Hinge Pin (CLIP2032) Qty - 2	Gas Strut Standard (STRT0005-2) Qty - 2	Jacking Bracket (CLIP2646PC) Qty - 2	Lock Striker Bracket (CLIP2499-PC) Qty - 2	Striker U-Bolt (LOCK0006) Qty - 2	M8 Hex Nut (NUTS0217) Qty - 2
	<b>13</b>	<b>14</b>	<b>15</b>	<b>16</b>	<b>17</b>	<b>18</b>	<b>19</b>	<b>20</b>
								
	Rivet (FAST0609) Qty - 5	Rivet (FAST0505) Qty - 8	M6x20 Hex Head Bolt (SCRW0028) Qty - 18	M6 Flat Washer (WASH0153) Qty - 34	M6 Nyloc Nut (NUTS0016) Qty - 12	M8x50 Hex Head Bolt (SCRW0789) Qty - 2	Ball Strut Bracket (CLIP2034-1) Qty - 2	M6 Hex Nut (NUTS0161) Qty - 8
	<b>21</b>	<b>22</b>	<b>23</b>	<b>24</b>	<b>25</b>	<b>26</b>	<b>27</b>	<b>28</b>
								
	Scrivet (FAST0086) Qty - 2	Spacer (MISC3265) Qty - 2	Washer (WASH0169) Qty - 4	EPDM Gasket (TAPE0419) Qty - 4	Alcohol Wipe (MISC0052) Qty - 4	Rust Inhibitor (MISC2776) Qty - 2	Support Bracket for Striker Bracket (CLIP2849PC) Qty - 2	Spring Washer (WASH0103) Qty - 4
	<b>29</b>	<b>29</b>	<b>29</b>	<b>29</b>	<b>29</b>	<b>29</b>	<b>29</b>	<b>29</b>
								
	Fitting Instruction (FIT-TC0297b) Qty - 1	Fitting Instruction (FIT-TC0297b) Qty - 1	Fitting Instruction (FIT-TC0297b) Qty - 1	Fitting Instruction (FIT-TC0297b) Qty - 1	Fitting Instruction (FIT-TC0297b) Qty - 1	Fitting Instruction (FIT-TC0297b) Qty - 1	Fitting Instruction (FIT-TC0297b) Qty - 1	Fitting Instruction (FIT-TC0297b) Qty - 1

**PARTS IN KIT (KIT032489)**

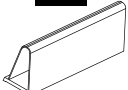
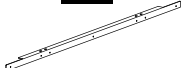
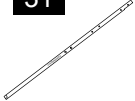
	<b>29</b>	<b>30</b>	<b>31</b>
			
	Header Rail Seal (MISC2229-9) Qty - 1	Header Rail (HBAR0013-1) Qty - 1	Side Drill Template (MISC3452) Qty - 1

**TOOLS REQUIRED:**

- Fine Point Non Permanent Marker
- Centre Punch
- Drill
- Ø3, Ø5, Ø6 & Ø7mm Drill Bits
- Torque Wrench
- Rivet Gun
- Scissors or Sharp Knife
- Spanners
- Socket Set
- Non-acetic Silicone
- Phillips Screwdriver (No 3)
- Allen Key
- Tape Measure
- Masking Tape

# MAZDA BT-50 - 3 PIECE HARD TONNEAU COVER



## IMPORTANT - BEFORE INSTALLING TONNEAU COVER

Remove & retain the Sports Bar and all Hardware.

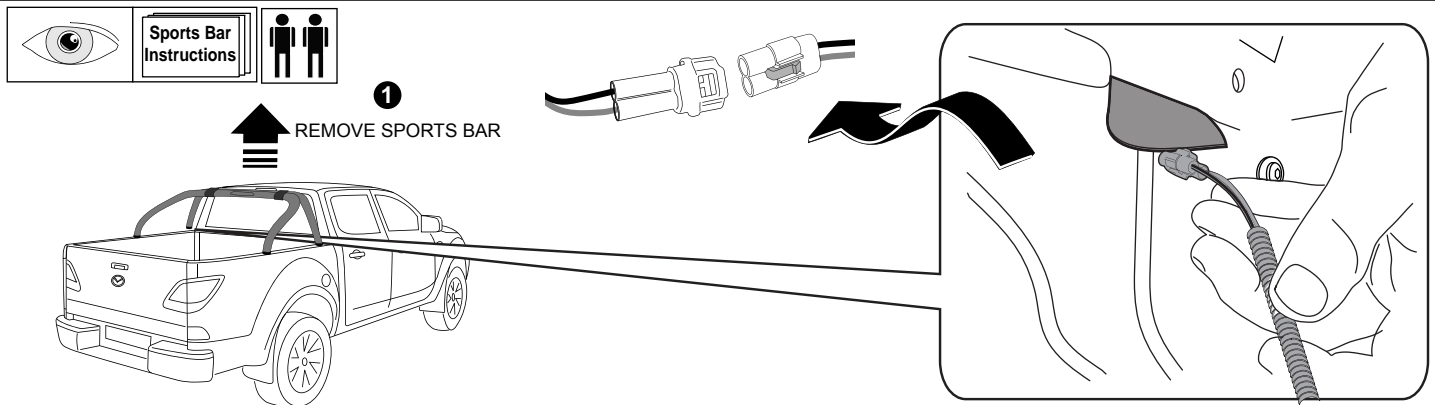

Diagram #:1

1. **NOTE: Two people are required to complete the installation.**

Pull the Stop Lamp wiring Loom from the hole in the front left hand corner of the vehicle tub, where the front left hand side foot is located and disconnect the Connector. Remove the Sports Bar and retain all the hardware.

See Dia #1.

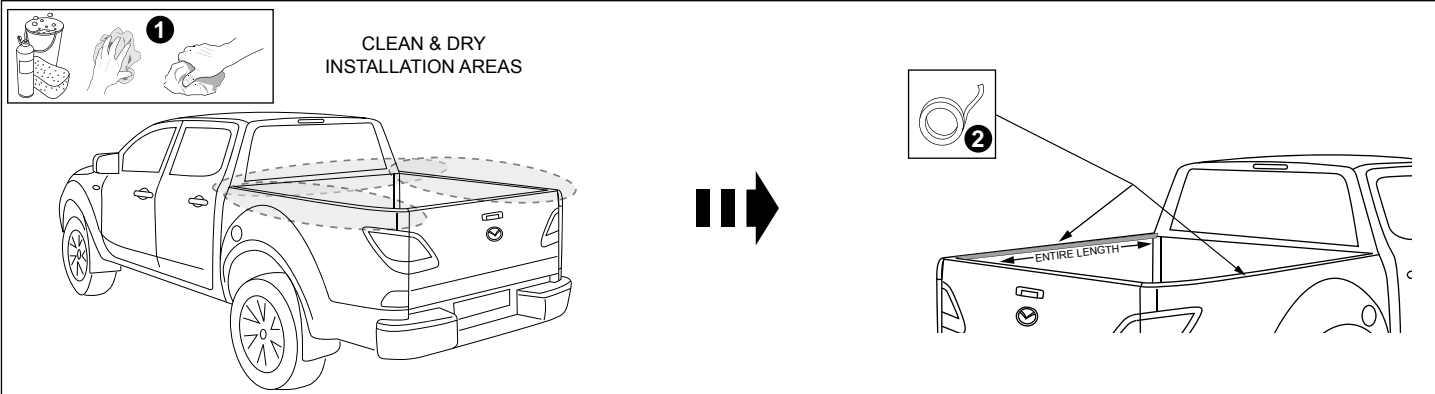

Diagram #:2

2. Thoroughly clean and dry the installations areas. Place masking tape in sections along the entire length of the side rails as shown.

See Dia #2.

IF VEHICLE IS FITTED WITH A BEDLINER GO TO STEP 3, OTHERWISE PROCEED TO STEP 4

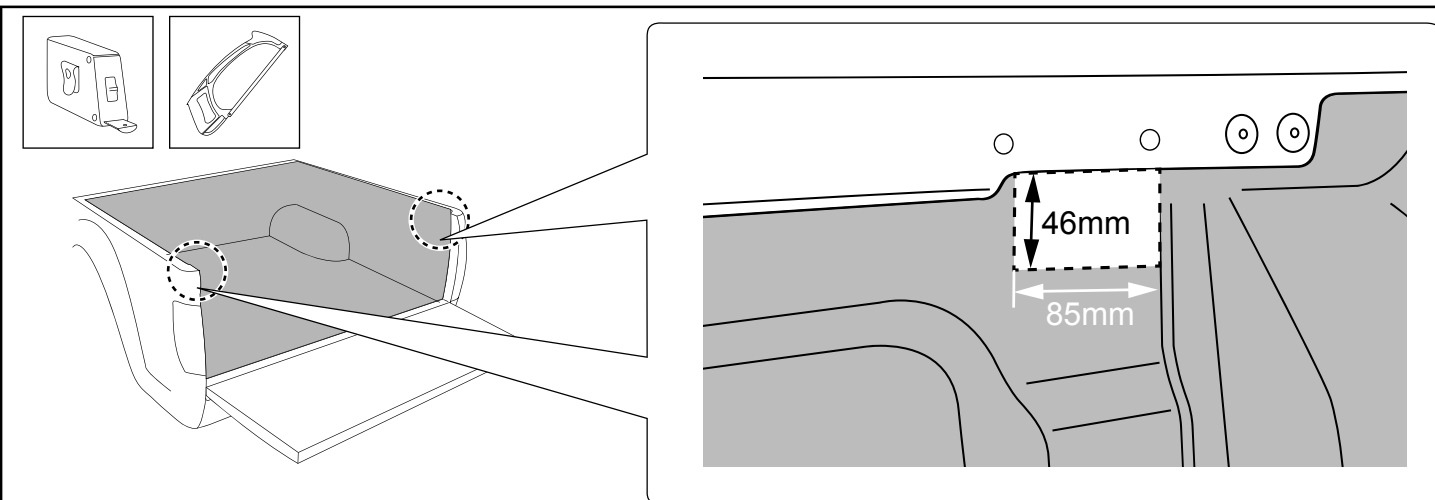
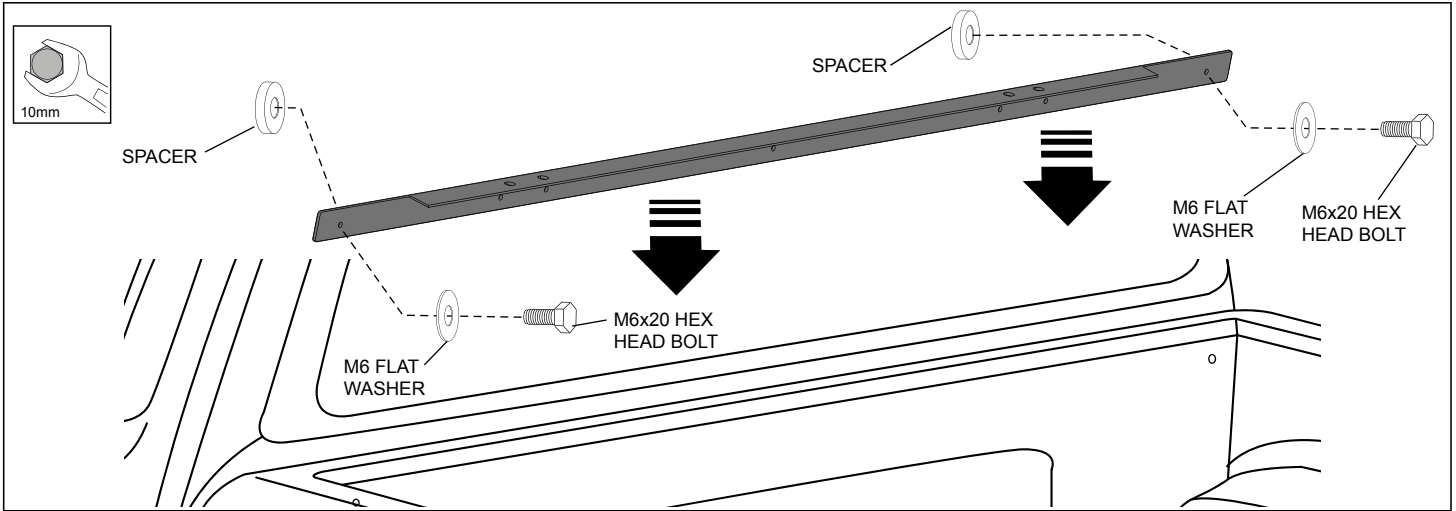

Diagram #:3

3. Trim the bedliner to clear the Striker Support Bracket as per the dimensions shown for the RHS. Repeat for LHS.

If necessary, remove the tub liner to make trimming easier. See Dia #3.

# MAZDA BT-50 - 3 PIECE HARD TONNEAU COVER

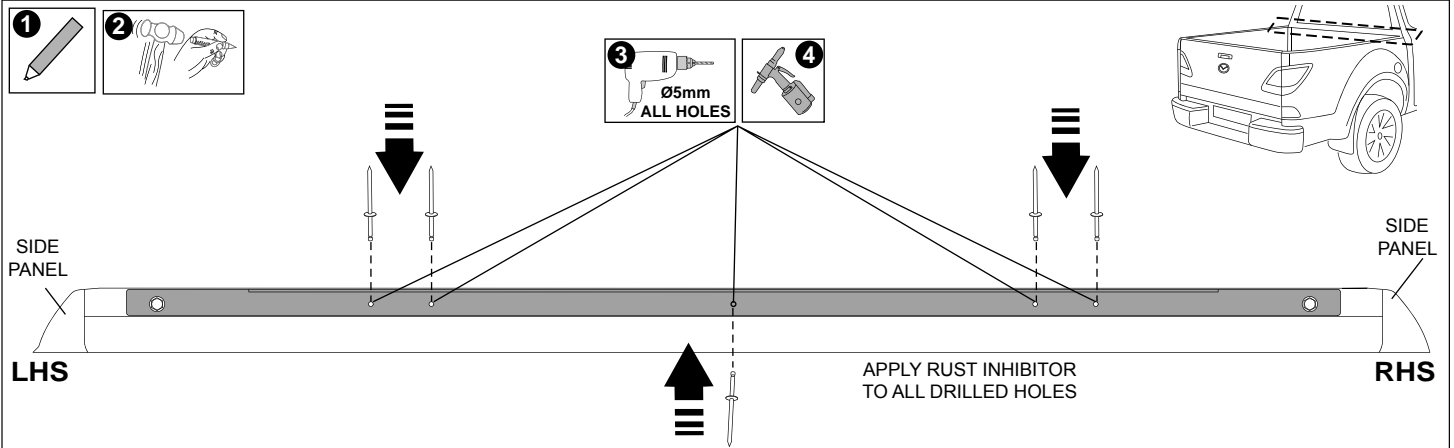

**Diagram #:4**

4. Attach header rail to the front of the tub using two M6x20 screws and washers and spacers between the header rail and tub.  
**NOTE: Make sure the spacers are fitted onto the bolts behind header rail. See Dia #4.**

**CONTINUE ON THE NEXT PAGE**

# MAZDA BT-50 - 3 PIECE HARD TONNEAU COVER



**Diagram #:5**

5. Mark and center punch the five hole locations in header rail. Drill five (5) holes through the tub using 5mm drill. Remove all burrs, sharp edges and swarf from vehicle. Apply rust inhibitor to all drilled holes. Rivet the header rail to the tub using five (5) black rivets.  
**NOTE: Top of header rail is to be flush with top of front bed rail. See Dia #5.**

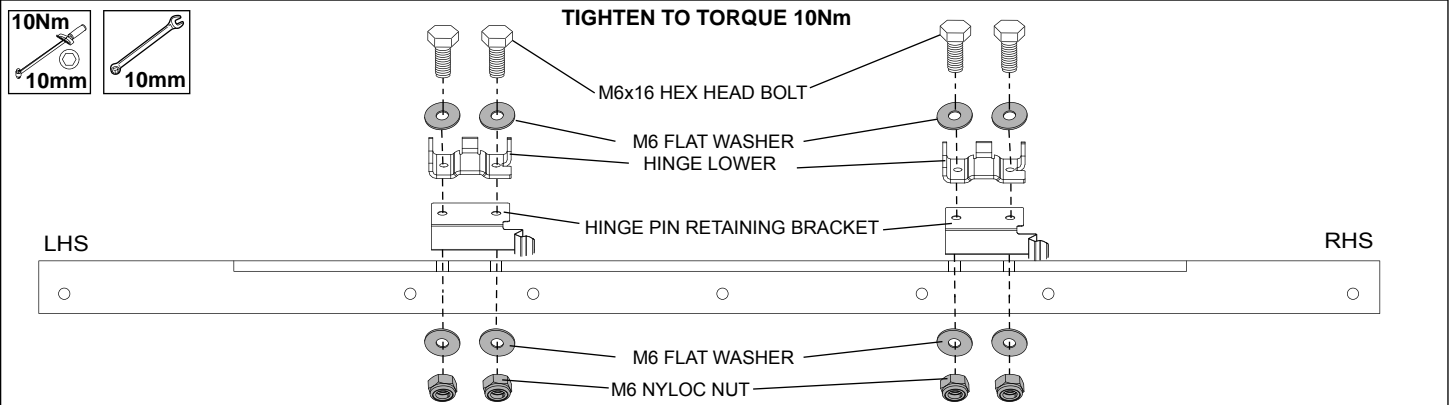

**Diagram #:6**

6. Orient the two (2) lower hinges as shown. Align the holes in the hinge lower with the slots in the header rail. Secure with two (2) M6x20 hex head bolts, four (4) M6 flat washers small and two (2) M6 nyloc nuts for each hinge as shown. Do not overtighten at this point. Allow side to side movement for adjustment once the tonneau cover is installed (Step#17). See Dia #6.

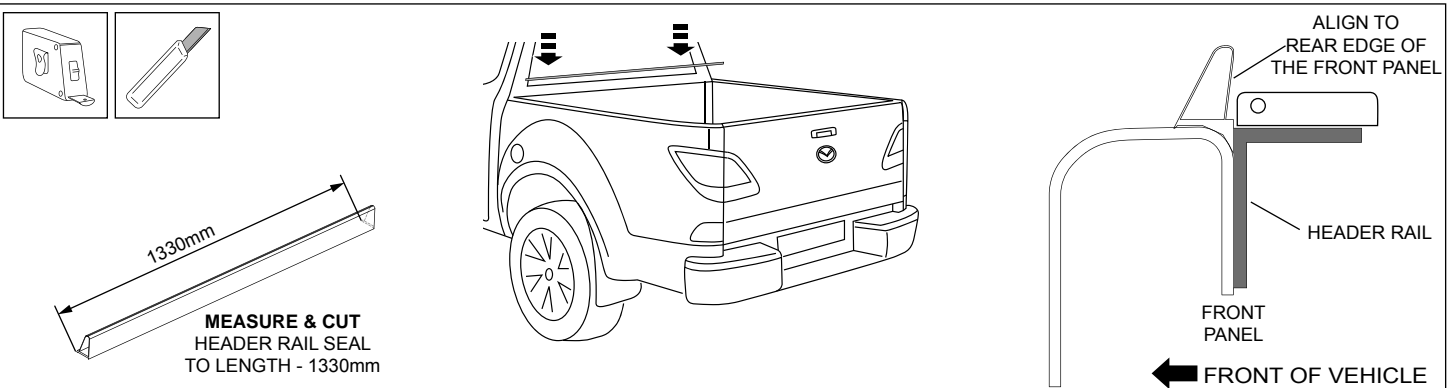

**Diagram #:7**

7. Measure and cut header rail seal to a length of 1330mm. Locate the centre of the header rail seal and trial fit to the front panel, ensure seal is oriented correctly and centred to the tub. Remove approximately 50mm length from one end of liner. Orient and align centre of seal with centre of front panel and rearward edge of seal against the lower hinge as shown. Starting from one end apply firm pressure and remove liner along the length of the seal, ensuring seal runs parallel with the edge front panel. See Dia #7.

# MAZDA BT-50 - 3 PIECE HARD TONNEAU COVER

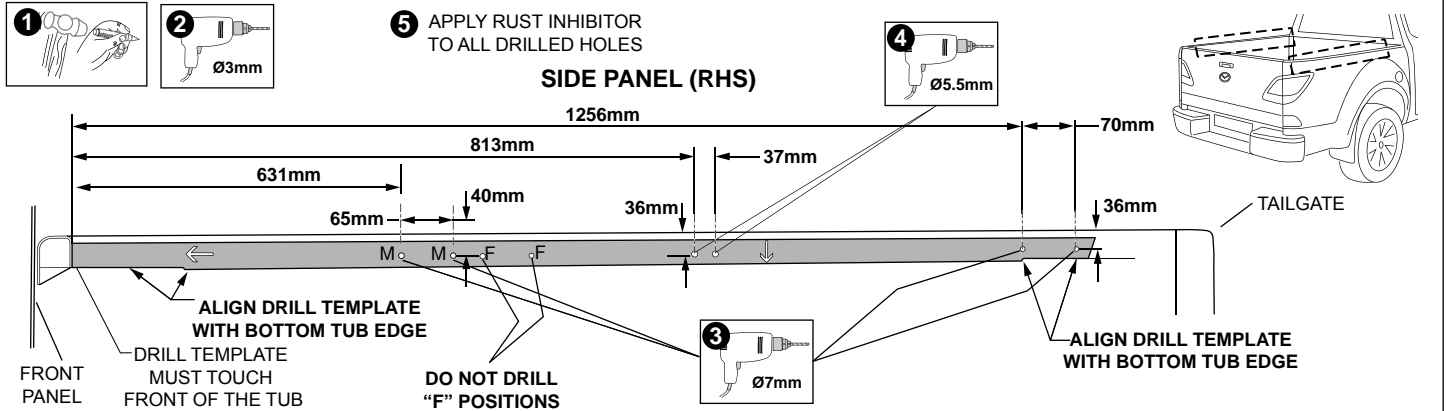

**Diagram #:8**

8. Position the side drill template flush to the side of the tub bed rail as shown, ensuring arrows are facing down and to the front of the vehicle. Drill template shape matches bottom shape of the side panel, at the front and rear positions shown. Hold in position using masking tape. Mark and centrepunch all required hole positions. Drill all holes with Ø3 pilot drill and remove the drill template. Drill four (4) holes Ø7mm and two (2) Ø5.5mm as shown. Repeat process by reversing the template to use on the other side of the vehicle. Remove all masking tape from the side rails. Remove all burrs, sharp edges and swarf from vehicle. Apply rust inhibitor to all drilled holes. **See Dia #8.**

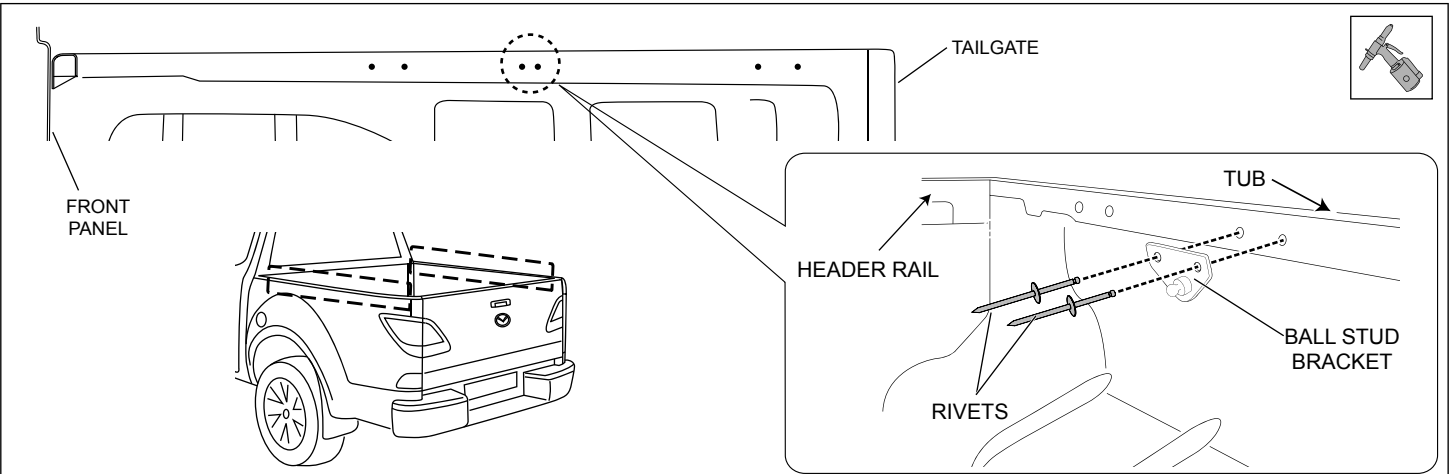

**Diagram #:9**

9. Fit the ball stud bracket to the side rail and secure with two (2) rivets (center pair of holes as shown in the side view above). Repeat process for the other side of the vehicle. **See Dia #9.**

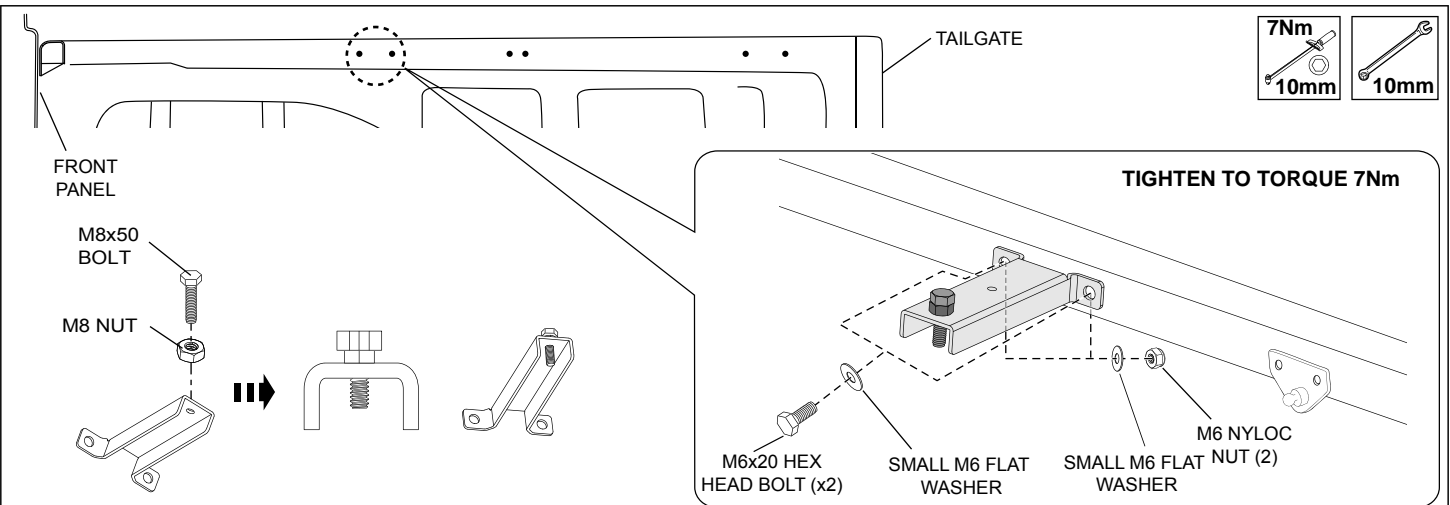

**Diagram #:10**

10. Pre-assemble M8x50 bolt and M8 nut into each jacking bracket as shown ensuring it is screwed all the way down at this point as shown. Secure jacking bracket to the vehicle with two (2) M6x20 hex head bolts, four (4) M6 flat washers large, and two (2) M6 nyloc nuts as shown. Repeat process for the other side of the vehicle. **Tighten to Torque 7Nm. See Dia #10.**

# MAZDA BT-50 - 3 PIECE HARD TONNEAU COVER

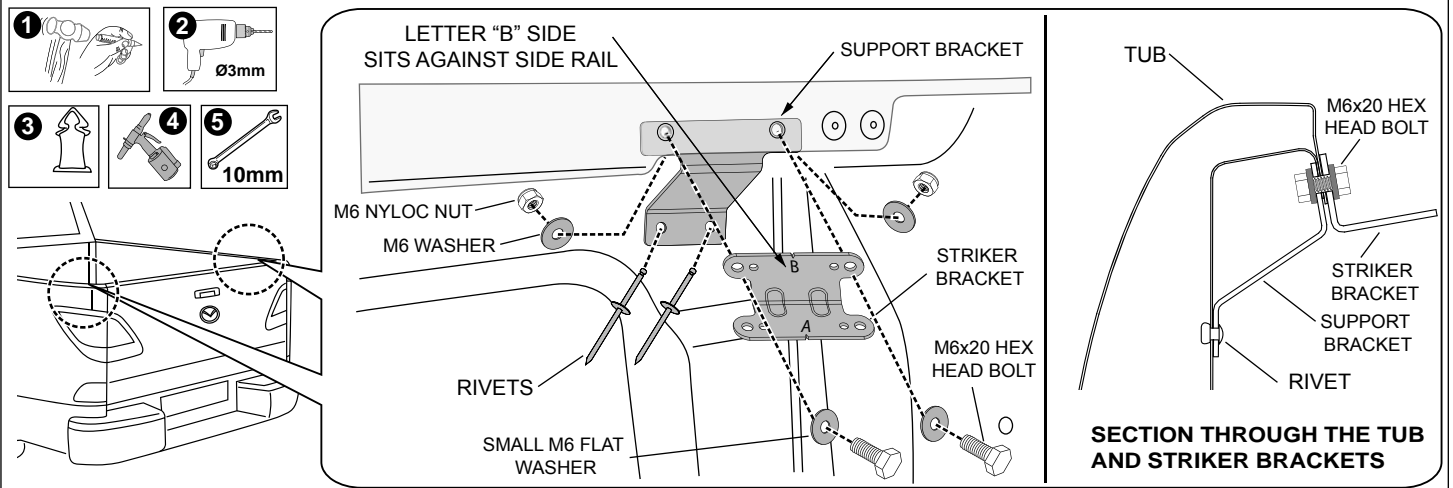

**Diagram #11**

11. Attach the striker bracket and support bracket to the tub using M6 screws, M6 washers, M6 nylock nuts and rivets. Note the orientation of the striker bracket. Position face "B" of lock striker bracket against the side rail as shown. Centerpunch and drill Ø5.5mm the two lower holes in the support bracket and secure with two rivets. Tighten all bolts to 9Nm. **See Dia #11.**

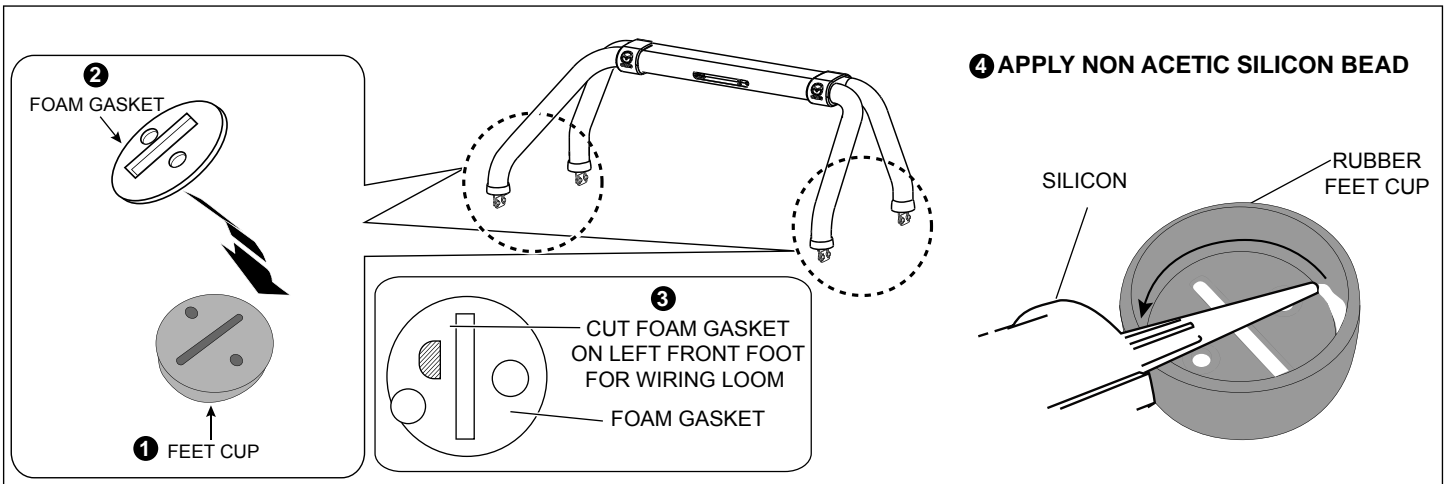

**Diagram #12**

12. Remove all four (4) caps from the Sports Bar. Remove protective lining from foam gaskets provided and adhere them to underside of rubber feet cups of the Sports Bar. Apply a bead of non acetic silicon (not supplied) around the inside surface of the foot cap. Replace the foot caps.

**See Dia #12. NOTE: On left hand front foot cut foam gasket to accommodate wiring loom to pass out of the Sports Bar.**

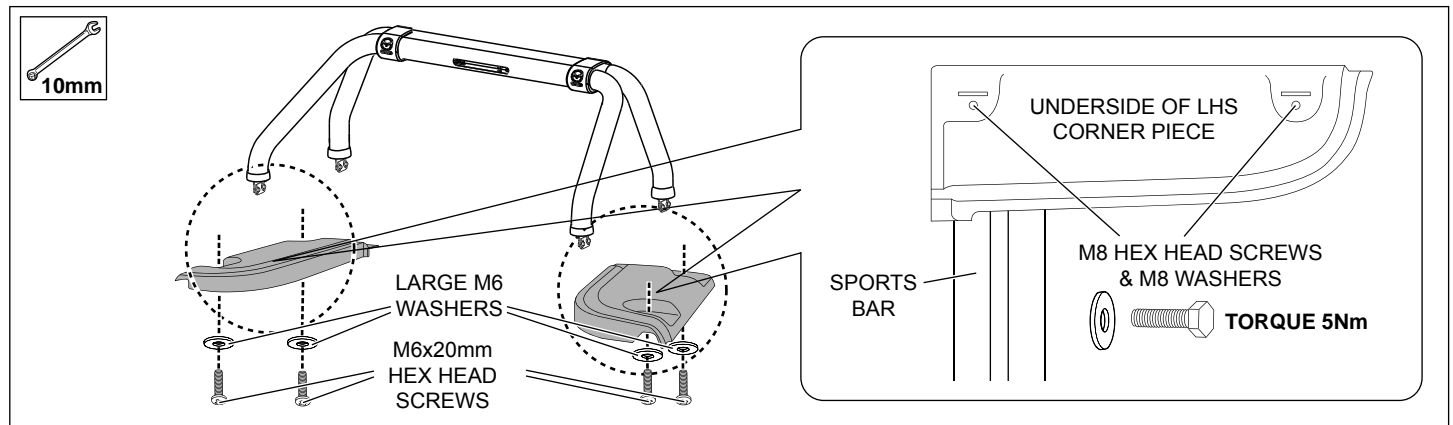

**Diagram #13**

13. **IMPORTANT: Be careful not to scratch the painted corner pieces when fitting them to the Sports Bar.** Install the corner piece using the M6x20 hex head screws and M6 large flat washers as shown. Do not tighten at this point to allow adjustment of position once installed to vehicle. Repeat for the other side of the vehicle. **See Dia #13.**

# MAZDA BT-50 - 3 PIECE HARD TONNEAU COVER

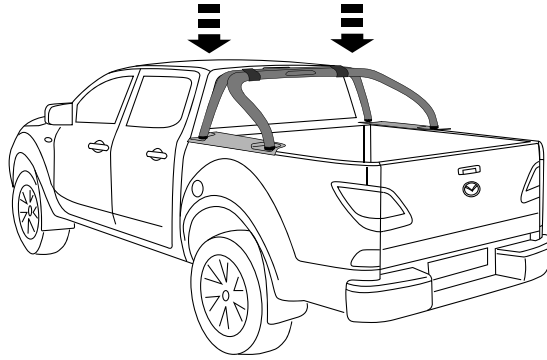
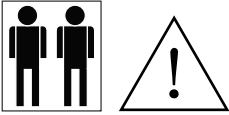

**Diagram #14**

14. Carefully position the assembled sportsbar and corner pieces onto the tub, taking care not to scratch the vehicle.

**NOTE: Two people are required to lift into position. See Dia #14.**

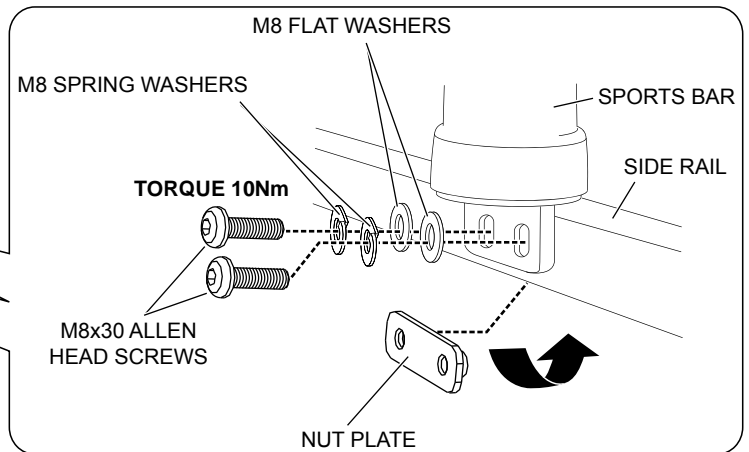
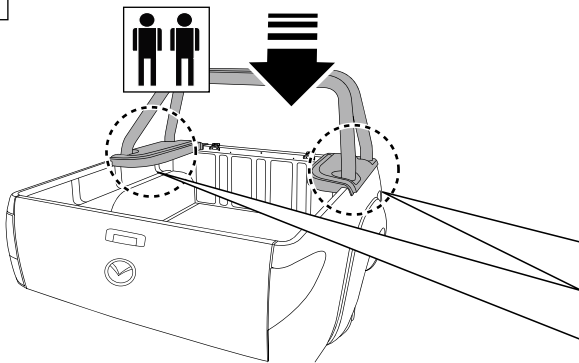

**Diagram #:15**

15. Reinstall Sports Bar to vehicle. Tighten all previously removed Sports Bar screws to torque 15Nm. Tighten screws between corner pieces and sports bar. Repeat for the other side of the vehicle. **See Dia #15.**

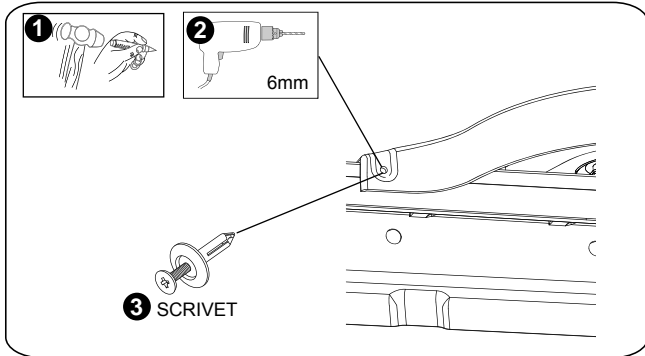
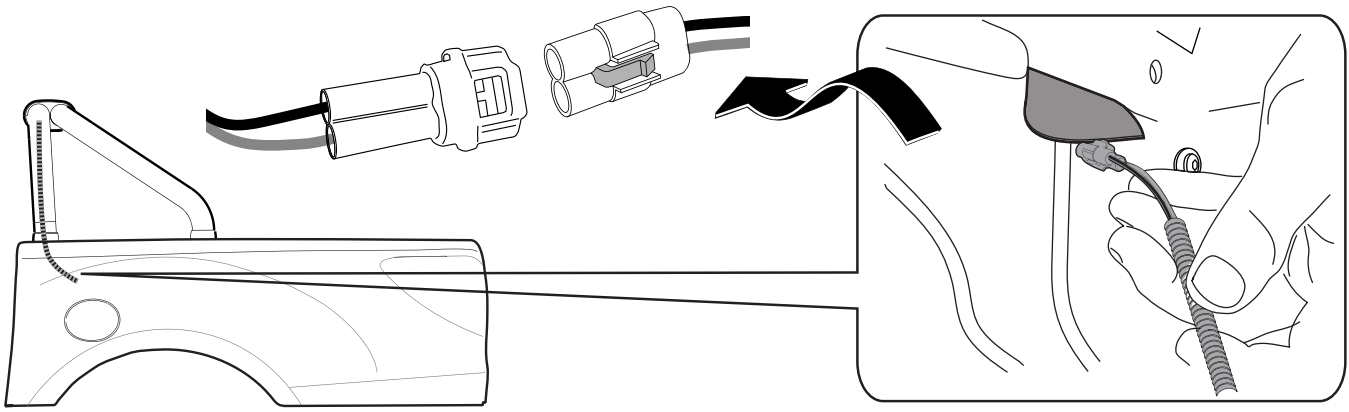

**Diagram #:16**

16. Two people are required for this step, one to apply firm pressure and the other to mark the positions. Apply pressure to push the corner piece and front sports bar feet firmly into the front corner of the tub and down onto the side rail. Mark and centre-punch the scrivet hole position. Repeat process for the other side of the vehicle. Carefully remove sports bar and corner piece assembly. Drill the marked hole with 6mm drill and apply rust inhibitor. Place the sports bar back onto the tub and secure the sports bar to the tub with the sports bar hardware. Reconnect the stop light wiring and refit the sports bar support bracket covers. Push the scrivets (2) into position. **See Dia #16.**



# MAZDA BT-50 - 3 PIECE HARD TONNEAU COVER



**Diagram #17**

17. Connect the Stop Lamp wiring and push back into the hole in the tub. See Dia #17



**IMPORTANT:** Ensure vehicles's tailgate is opened before installing Tonneau Cover, and remains open until lock striker is fitted and locking mechanism is adjusted correctly. **DO NOT** close the Tailgate when the Hard Tonneau is in the closed position, as damage may occur to the vehicle and/or your Tonneau Cover!



TONNEAU SEAL FITMENT OVER HEADER RAIL SEAL

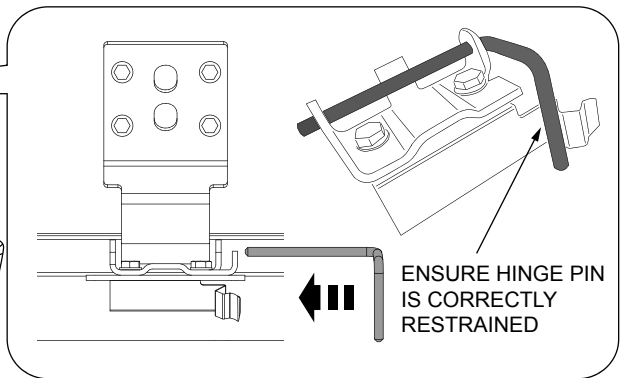
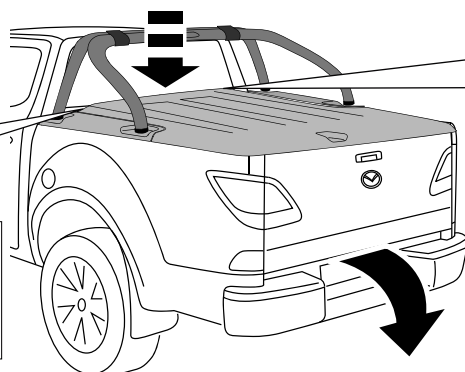
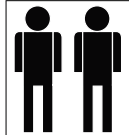
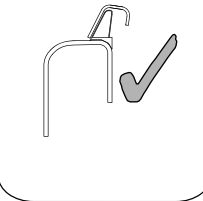

**Diagram #:18**

18. Open vehicle's tailgate and keep it open until locking mechanism has been adjusted correctly. Two people are required to carry out the fitment of the tonneau cover. Carefully fit tonneau cover to vehicle ensuring seal at the front of the tonneau cover sits correctly over the header rail seal as shown, If incorrectly placed this can direct water into the tub. Secure hinges with hinge pins as shown. See Dia #18.

**IMPORTANT:** Ensure hinge pins clip into retaining leg on lower hinges, ensuring pin is securely restrained. If misaligned, seal can be pushed forward from inside of the tub.

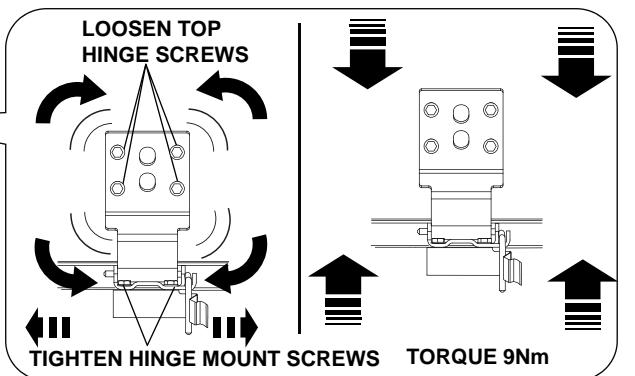
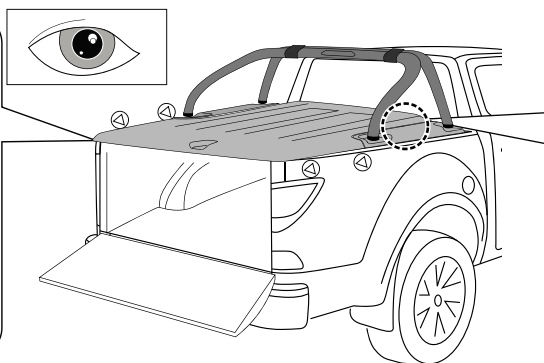
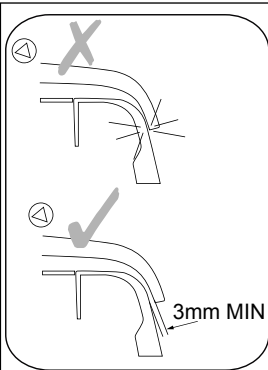
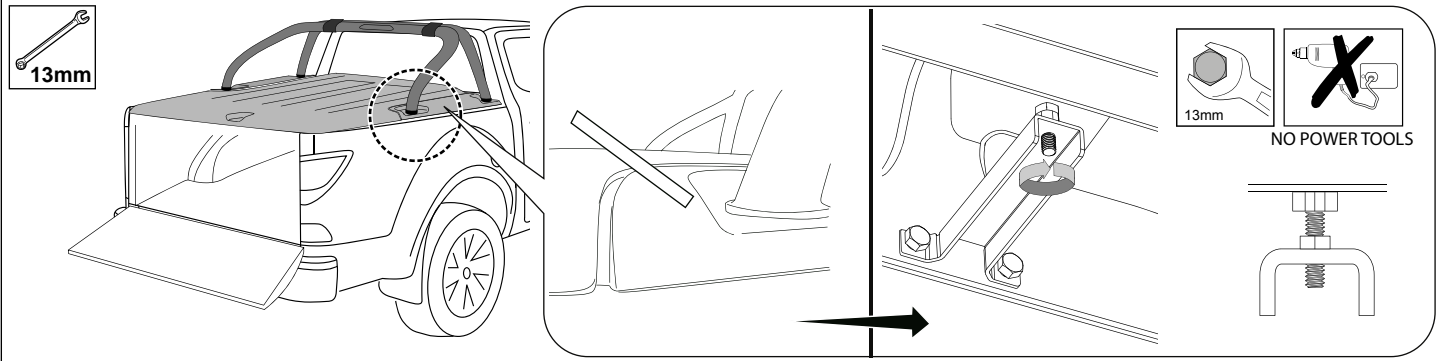

**Diagram #:19**

19. With tailgate open, close and check Tonneau Cover is central to vehicle and the sides of Tonneau Cover do not contact the vehicle bedrail. Adjust position by loosening the top hinge screws for fore and aft adjustment and hinge mount screws for side to side adjustment to re-position Tonneau Cover to fit centrally on vehicle. Before screwing tight, align each lower hinge section outwards in order to prevent side play. Tighten all hinge brackets to **Torque 9Nm**. See Dia #19.

**NOTE:** Corner pieces can also be adjusted if required by losing screws between corner pieces and sports bar.

# MAZDA BT-50 - 3 PIECE HARD TONNEAU COVER



**Diagram #:**20

20. Adjust jacking bracket bolt to level corner piece to the main surface of the Tonneau Cover. Once in the correct position, lock the bolt into position against the bracket by tightening the M8 nut using a 13mm spanner. Repeat process for the other side of the vehicle. **See Dia #20.**

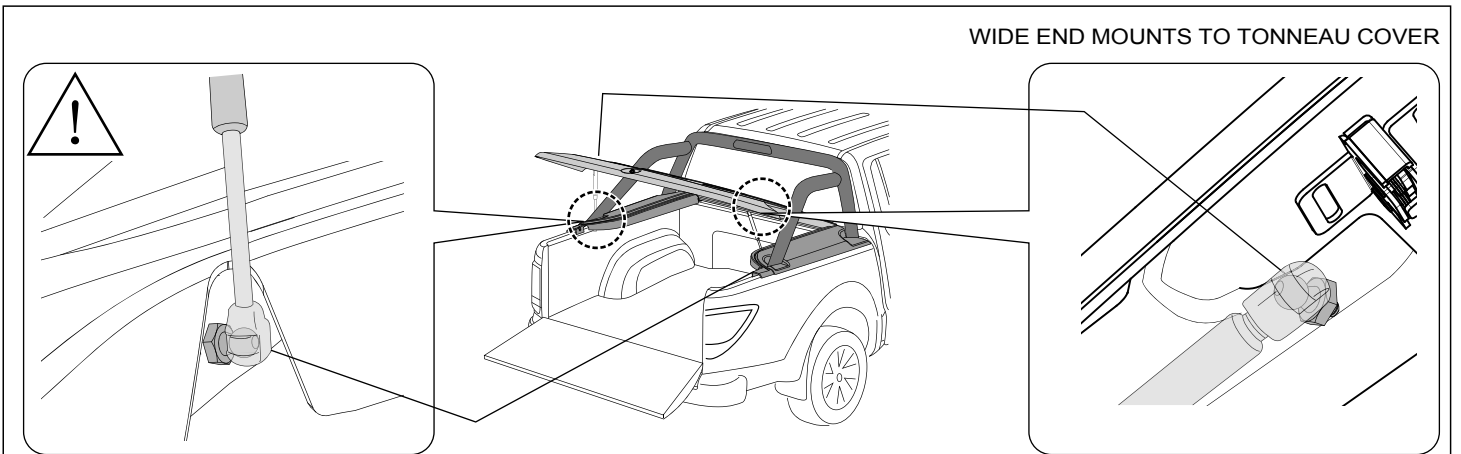

**Diagram #:**21

21. Attach gas struts by clipping into place as shown. **Ensure the narrow end mounts to the vehicle and the wide end mounts to the tonneau cover. See Dia #21. !! Failure to do so Voids Warranty on gas struts!!**

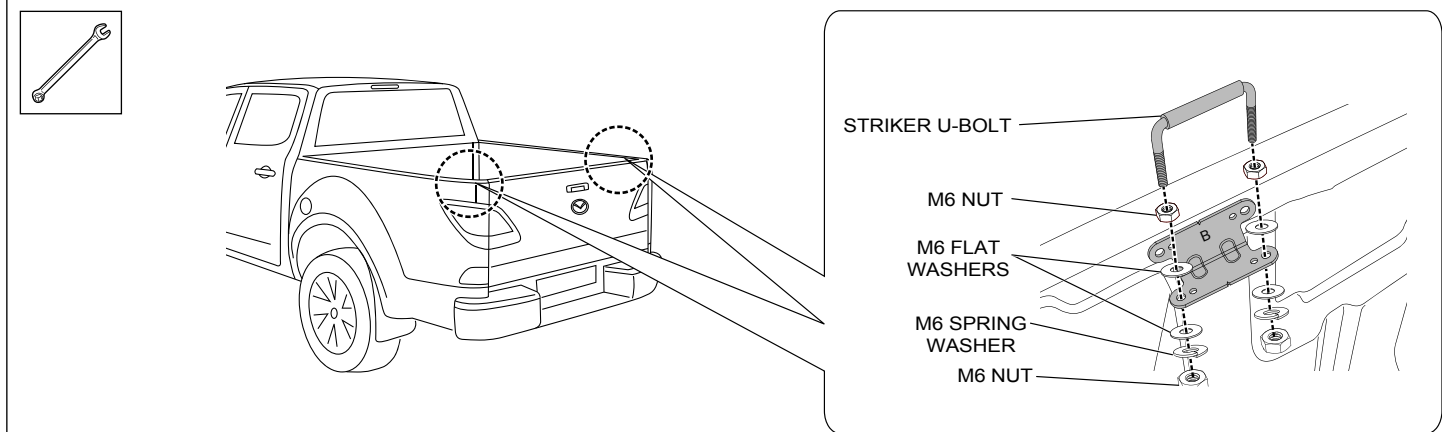

**Diagram #:**22

22. Fit the striker U-bolt to the striker bracket using nuts and washers as shown. **See Dia #22.**

# MAZDA BT-50 - 3 PIECE HARD TONNEAU COVER



**IMPORTANT: Ensure vehicle's tailgate is opened and remains open.  
Tonneau could lock during adjustment process.**

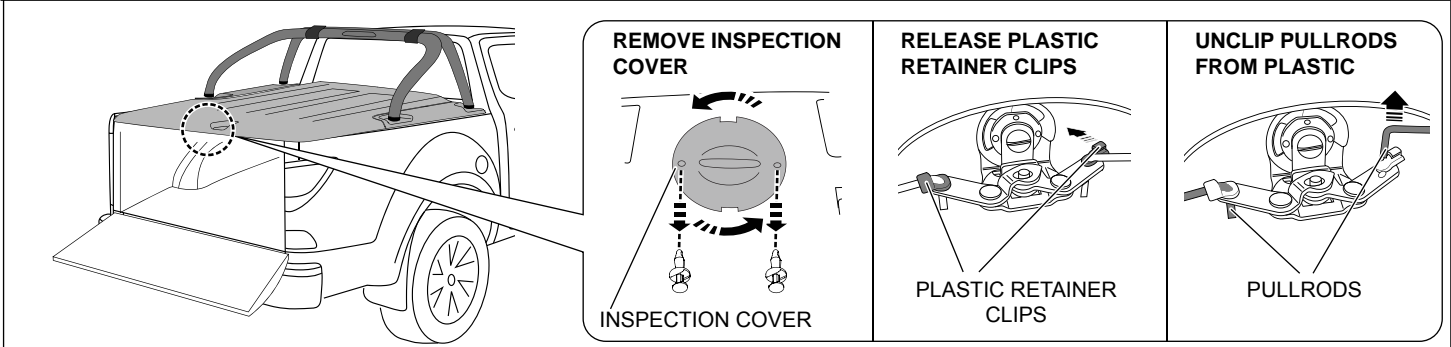

**Diagram #:23**

23. Open Tonneau Cover and remove inspection cover by removing scrivenets and rotating cover anti-clockwise. Release plastic retainer clips and unclip pullrods as shown. **See Dia #23.**

**IMPORTANT: TAILGATE MUST BE OPEN, TONNEAU COULD LOCK DURING ADJUSTMENT PROCESS.**

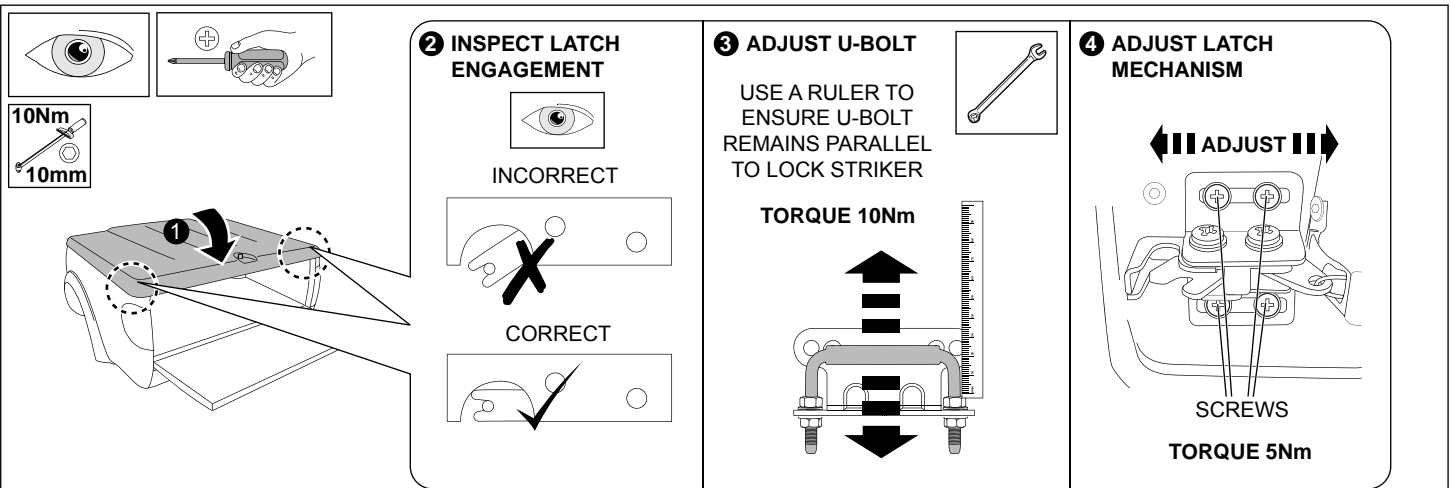
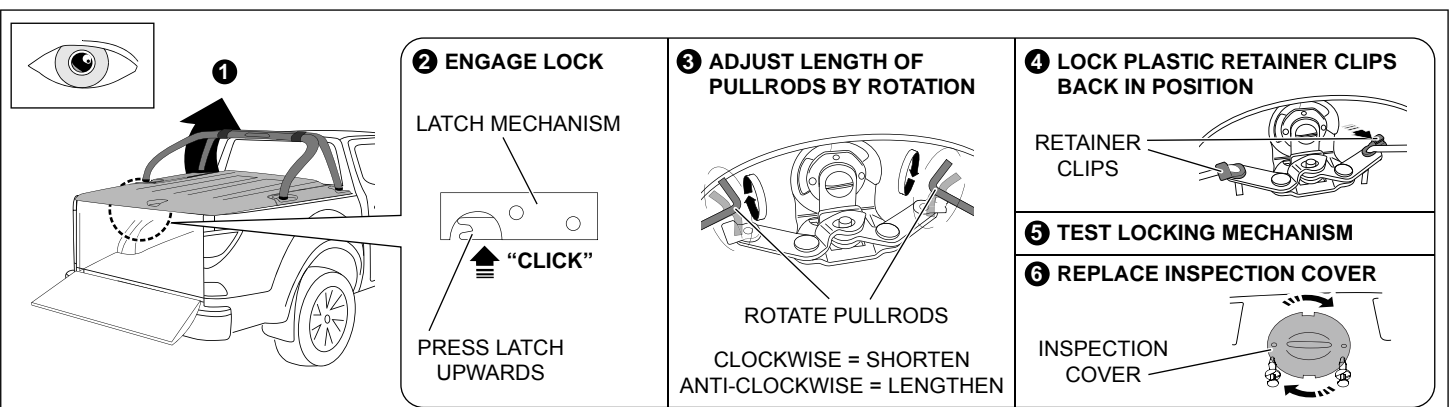

**Diagram #:24**

24. Close Tonneau Cover and inspect locking mechanism. Ensure the latch hits the striker bracket centrally. If it **DOES NOT**, adjust the latch accordingly by loosening the screws and moving the latch left or right as shown. Tighten to **torque 5Nm**.

Adjust the height of the lock striker bracket by moving it up or down as shown. Tighten nuts to **torque 9Nm**. **See Dia #24.**

**Note: Tonneau Cover has 2 stage locks as a safety feature. Ensure Tonneau engages with second stage of the latch.**



**Diagram #:25**

25. Open the Tonneau Cover and engage the lock by pressing upwards on the latch. Adjust pullrods so that they clip back into the retainer clips correctly. Do this by rotating them clockwise to shorten them or anti-clockwise to lengthen them (via internal turn buckle). Clip pullrods and retainer clips back into position. Test lock by pressing the button on top of Tonneau Cover. If latch mechanism **DOES NOT** release, return to **Step 3** and shorten the pullrods. If it **DOES** release, replace inspection cover. **See Dia #25.**

**IMPORTANT: Ensure that the Tonneau Cover locking mechanism is functioning correctly before closing tailgate.**

# MAZDA BT-50 - 3 PIECE HARD TONNEAU COVER

## REMOVAL OF TONNEAU COVER

TWO PEOPLE ARE REQUIRED TO CARRY OUT THE REMOVAL OF THE TONNEAU COVER.

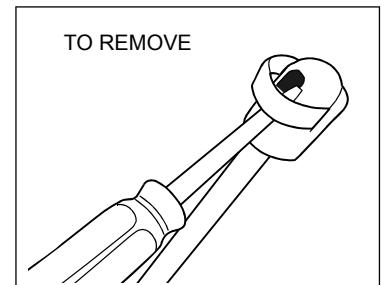
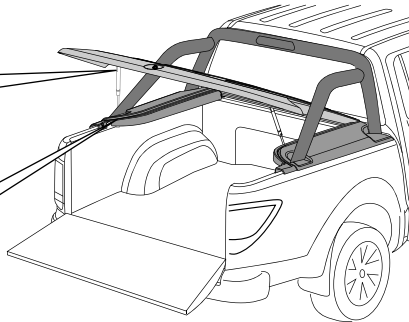
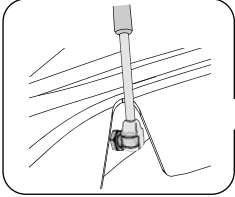
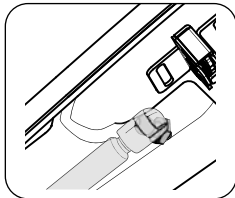
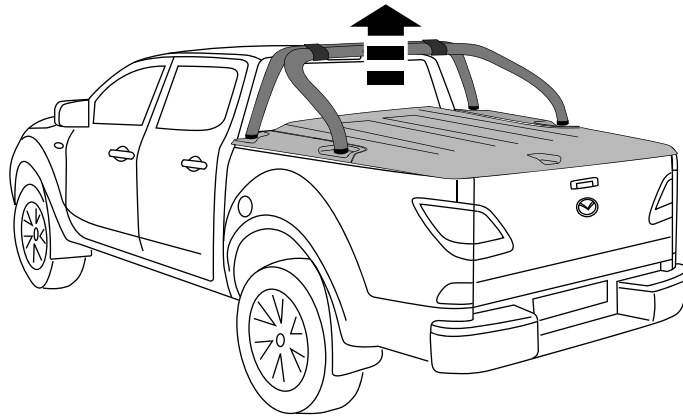

Diagram #:1

1. Detach gas struts by inserting a small screw driver and adjusting the spring clip on the strut. **See Dia #1.**  
**NOTE: Do Not remove the spring clip only a small amount of levering is required to detach.**  
**Do Not remove without using a tool, damage can occur and Void Warranty.**

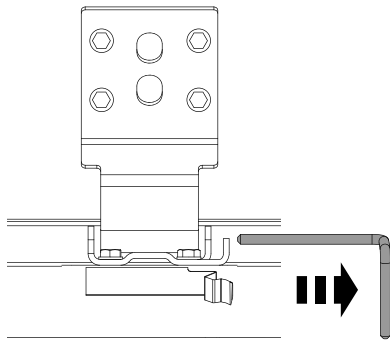

Diagram #:2

2. Remove hinge pins and then remove the Tonneau Cover. **See Dia #2.**