

1PC TONNEAU COVER INSTALLATION INSTRUCTIONS Isuzu D-Max 2012

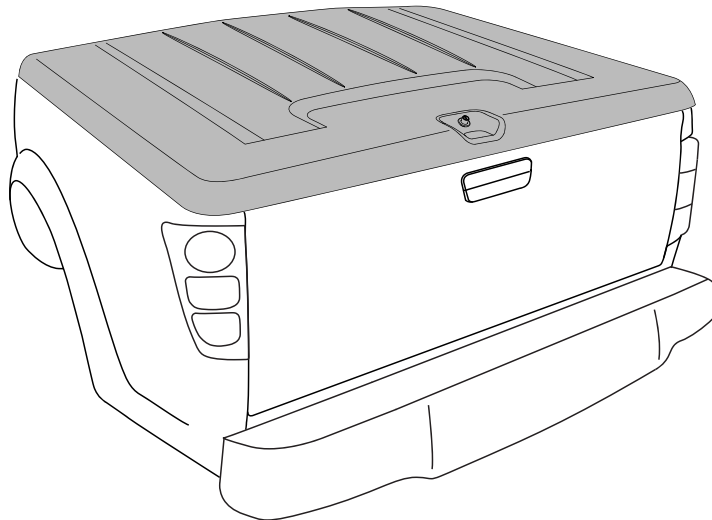

Installation Time:
2 Hour (Approximately)

PLEASE KEEP INSTRUCTIONS IN GLOVE BOX FOR FURTHER USE

RECOMMENDED TOOL LIST - (Not Supplied in Kit)

- | | | |
|-----------------------------|-----------------------------|----------------------------------|
| • Ø5.5, Ø7.0 mm Drill Bit | • Hammer & Centre Punch | • Tape Measure |
| • Drill | • Non-permanent Marker | • Masking Tape |
| • Cleaning Cloth | • Phillips Head Screwdriver | • Spanner 10,13mm |
| • Socket Wrench 10,12,13mm | • Rivet Gun | • Silicon Dispenser and Silicone |
| • Counter Sinking Drill Bit | • T40 size Torx Bit | • Torque Wrench |

IMPORTANT: To obtain correct installation, we recommend that you follow these step by step instructions carefully. Failure to do so may result in improper fit and or retention.

- Please take care when assembling and installing this product to protect the finish and your investment.

Finish Protection:

- Only use cleaners, waxes, or products that are labelled safe for use on plastics. Avoid the use of any chemicals to clean your Tonneau Cover unless labelled safe for plastics. Avoid use of abrasive type cleansers as they may dull the finish.
- If fuel is splashed onto the Tonneau Cover immediately wash it off with car washing detergent and water. If staining is apparent polish the stain out with a commercially available car polish.

Maintenance:



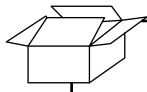

- The gas struts are self lubricating and should only be cleaned occasionally with a damp cloth. Premature seal failure will result if solvents or lubricants are used to clean struts.
- The locking mechanisms & Latches only require occasional lubrication with Graphite Powder. DO NOT use any other lubricants or oils. Using alternative products will VOID Warranty.
- All installation hardware and fasteners must be checked every so often for tightness.

Disclaimer: The buyer assumes all risk and liability whatsoever from the installation and use of our products. Our products are sold as decorative accessories and should not be relied upon as protection for the vehicle or occupants in the event of a collision or rollover. The manufacturer assumes no liability for injury, loss, incidental or consequential damages in the event of a collision or rollover.

PARTS CHECK SHEET

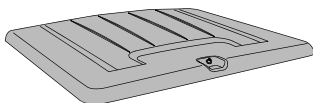

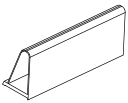

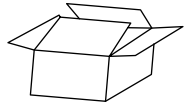

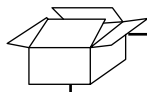





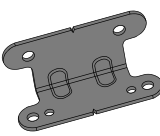

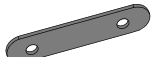
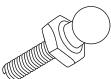

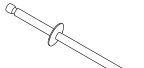



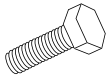



PARTS IN MAIN CARTON

1	2	22		
				
Tonneau Cover Qty - 1	Header Rail (HBAR0015) Qty - 1	Header Rail Seal (MISC2229-9) Qty - 1	Lock Keys (Attached to Tonneau) Qty - 2	Fitting Kit Qty - 1

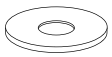

PARTS IN FITTING KIT

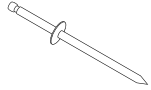
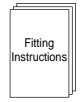
3	4	5	6	7	8	9
						
Hinge Pin (CLIP2808) Qty - 2	Gas Strut (STRT0021) Qty - 2	Striker Bracket (CLIP2874PC) Qty - 2	Striker U-Bolt (LOCK0006) Qty - 2	Striker Packer (CLIP2809PC) Qty - 2	Ball Stud Screw M6 (SCRW0724) Qty - 2	Corner Piece Moulding (INJM0012-1) Qty - 1 Pair
10	11	12	13	14	15	16
						
Pop Rivet (FAST0609) Qty - 3	M6 Small S/S Flat Washer (WASH0153) Qty - 8	M6 S/S Spring Washer (WASH0103) Qty - 4	M6 S/S Hex Nut (NUTS0161) Qty - 8	Rubber Thread Cap (MISC2532) Qty - 4	M8x25 Hex Head Bolt (SCRW0696) Qty - 4	M8 S/S Spring Washer (WASH0152) Qty - 4
17	18	19	20	21	23	
						
M8 S/S Flat Washer (WASH0171) Qty - 4	Rust Inhibitor (MISC2776) Qty - 1	Primer Stick (MISC1365) Qty - 2	Alcohol Wipe (MISC0052) Qty - 2	Side Rail Drill Template (MISC3674) Qty - 1	5mm Spacer (MISC3661) Qty - 2	
24	25	26	27	28	29	30
						
M6 Flat Washer Large (WASH0169) Qty - 4	M6 S/S Nyloc (NUTS0016) Qty - 2	M6 Counter Sunk Screw (SCRW0862) Qty - 1	Blackout Decal RHS (LABL1508) Qty - 1	Blackout Decal LHS (LABL1507) Qty - 1	Pop Rivet (FAST0441) Qty - 2	Fitting Instruction (FIT-TC0322) Qty - 1

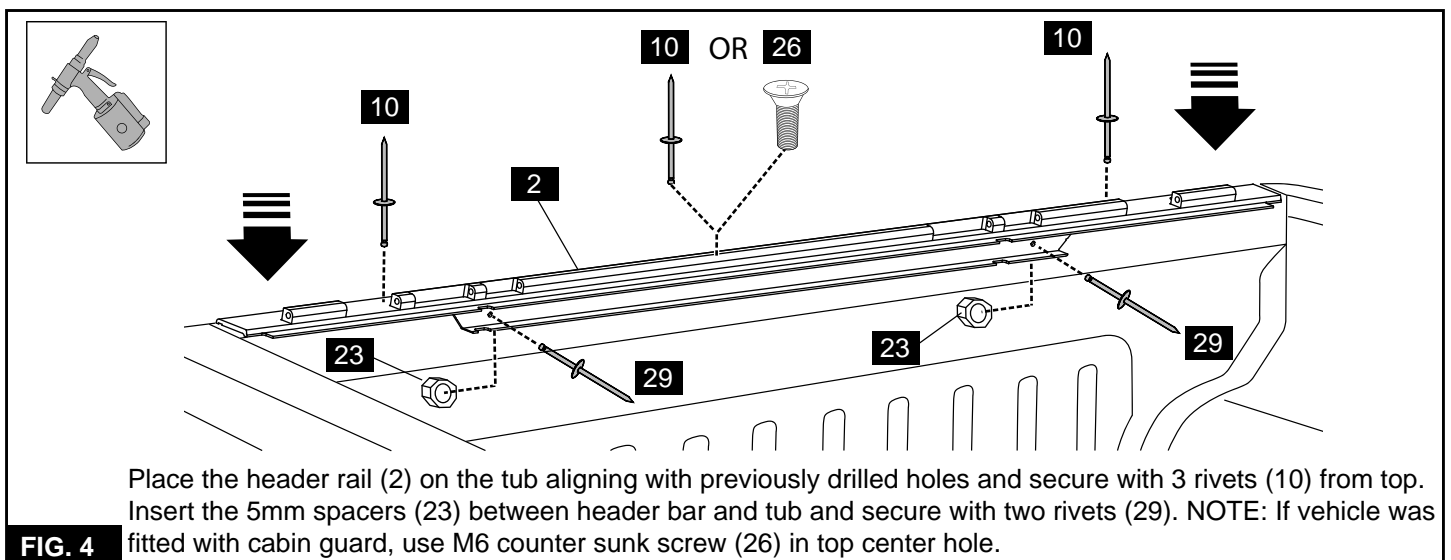
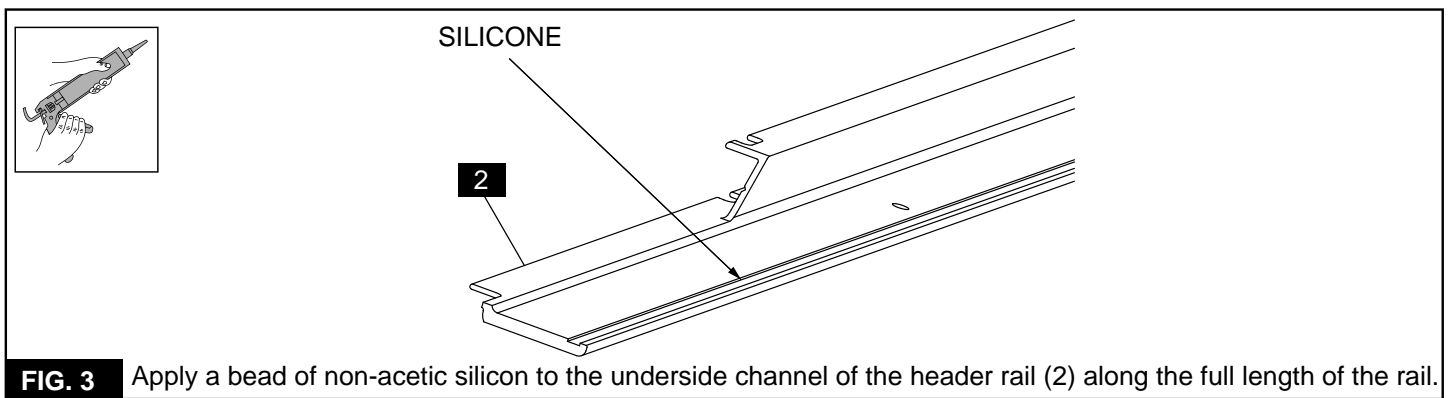
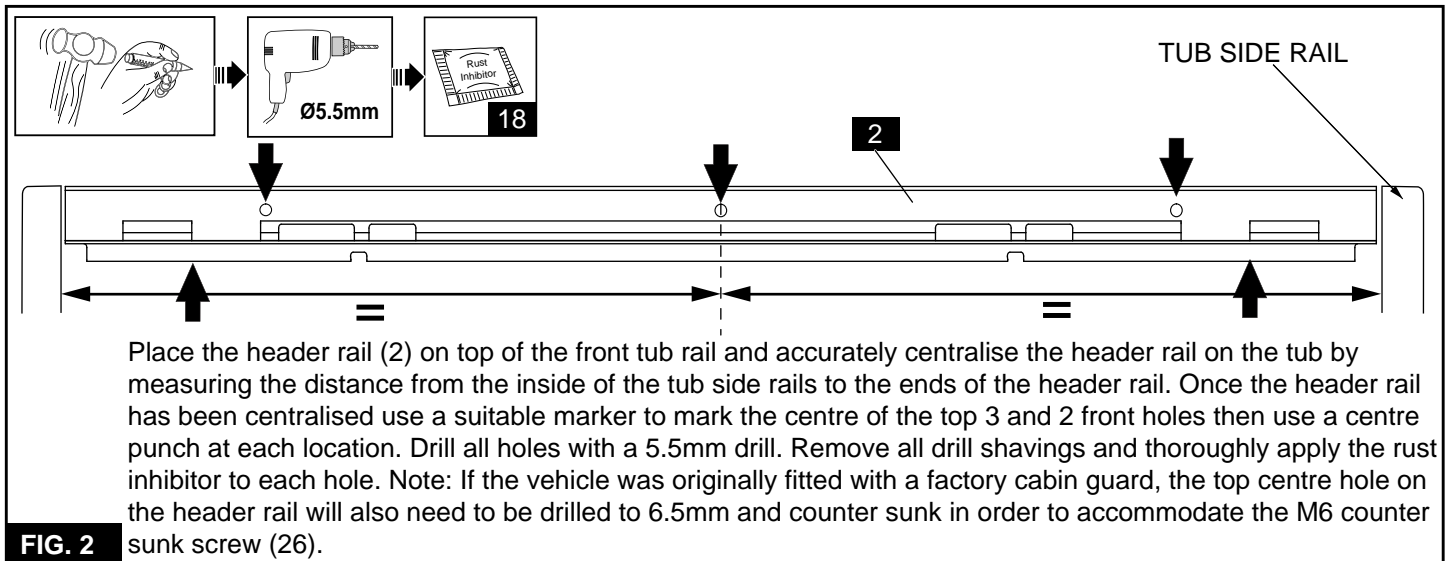
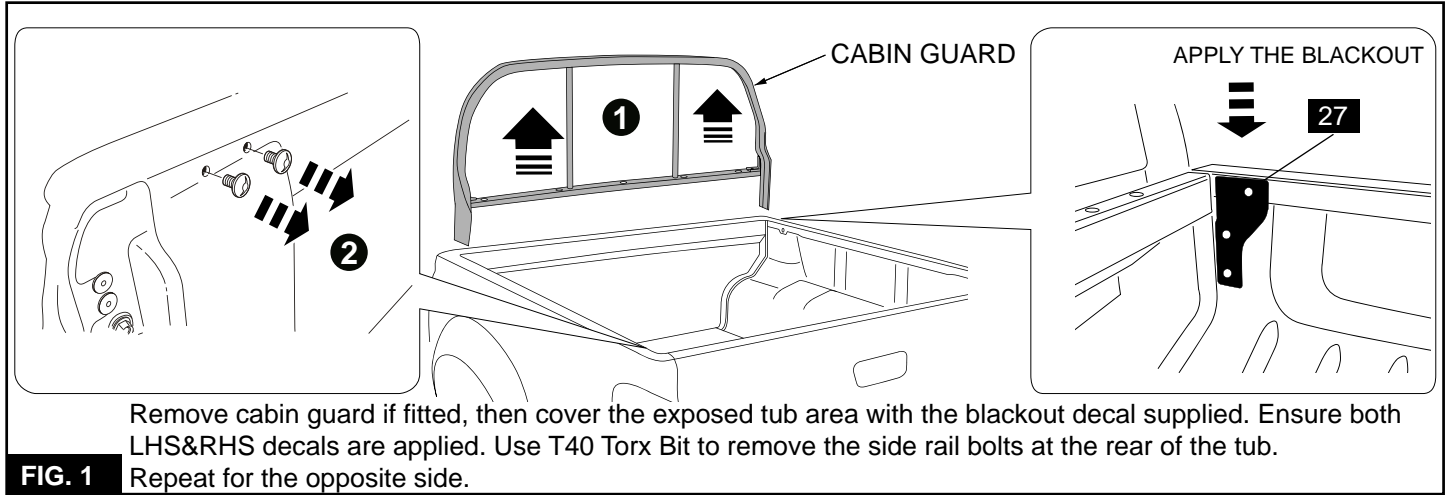

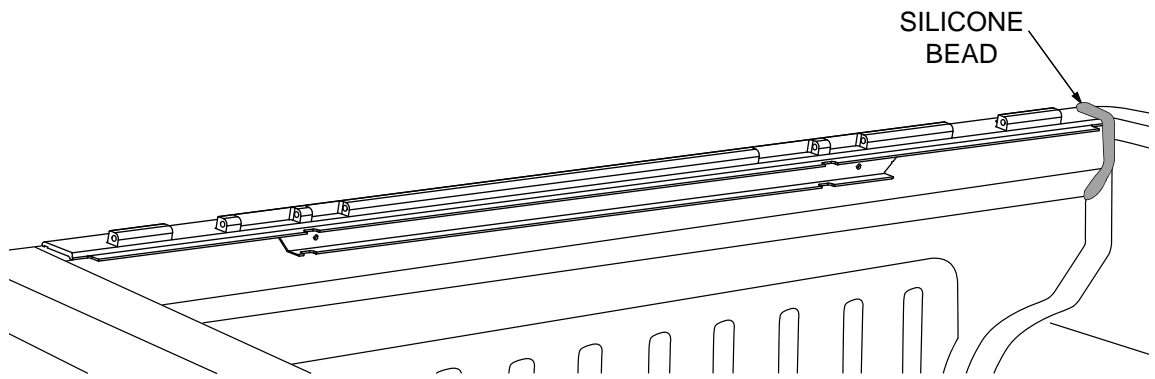
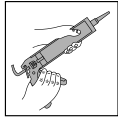

SILICONE
BEAD

FIG. 5

Apply bead of silicone along the end of the header bar between the join in the sheet metal and down the front, as illustrated above. Repeat on the other side of the tub.

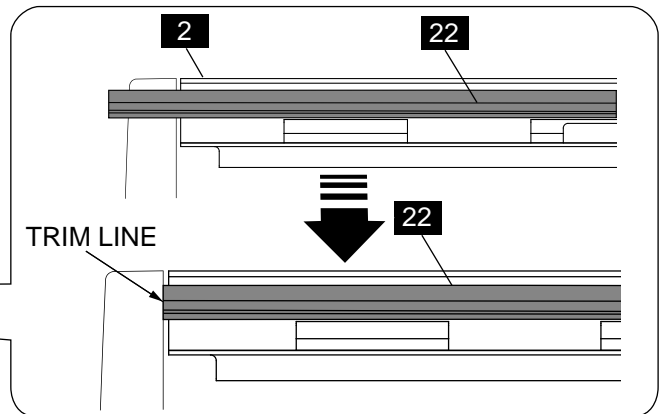
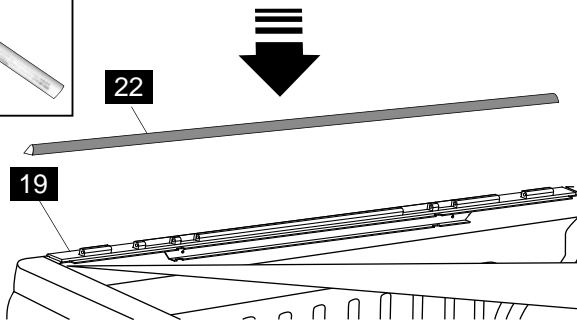
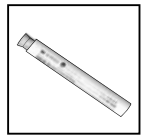

FIG. 6

Use the primer (19) to prime the top of the header rail and then apply the bulb seal (22) along the top of the header rail (2), ensuring it is central on header rail. Trim the bulb seal on each end in line with the side bed rail.

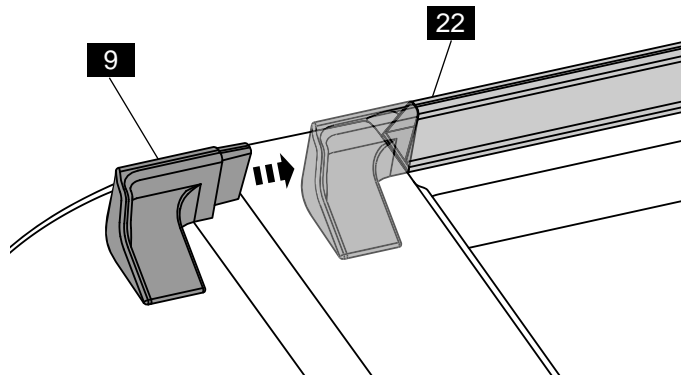
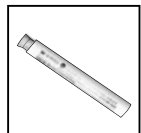

FIG. 7

Trail fit the corner piece (9) to the bulb seal (22) and mark its position. Clean the marked area and apply primer to the area. Remove tape liner from corner piece moulding and fit into header rail seal and apply firm pressure down onto side rail as shown. Repeat process for the other side of the vehicle.

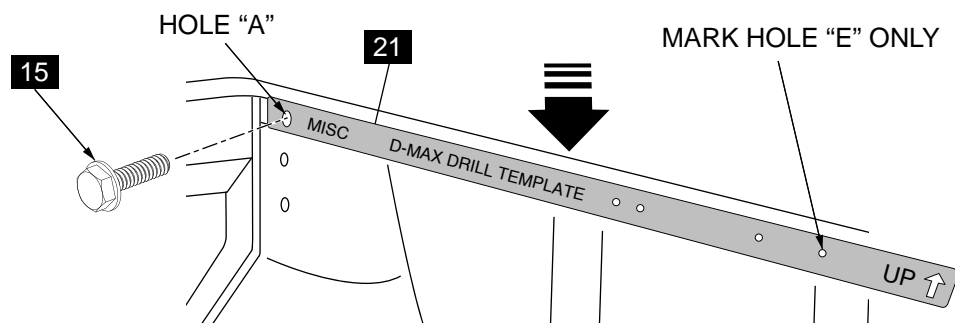
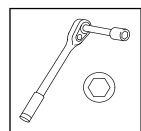

FIG. 8

Use the T40 Torx Bit to remove front side rail bolts from the tub and then position the drill template (21) on the inside of the tub rail, ensure arrow faces upwards and secure with M8 bolt through hole "A" in template. Ensure the template is aligned centrally on the inside of the side rail and mark the "E" hole only. Reverse the template and repeat for other side of tub.

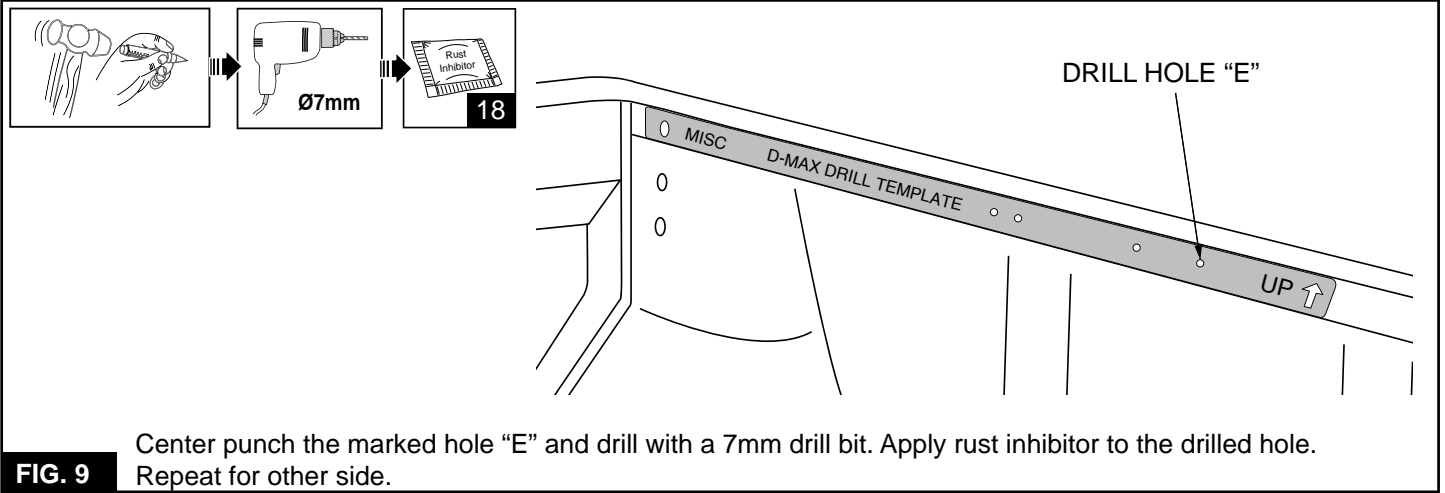

FIG. 9 Center punch the marked hole "E" and drill with a 7mm drill bit. Apply rust inhibitor to the drilled hole. Repeat for other side.

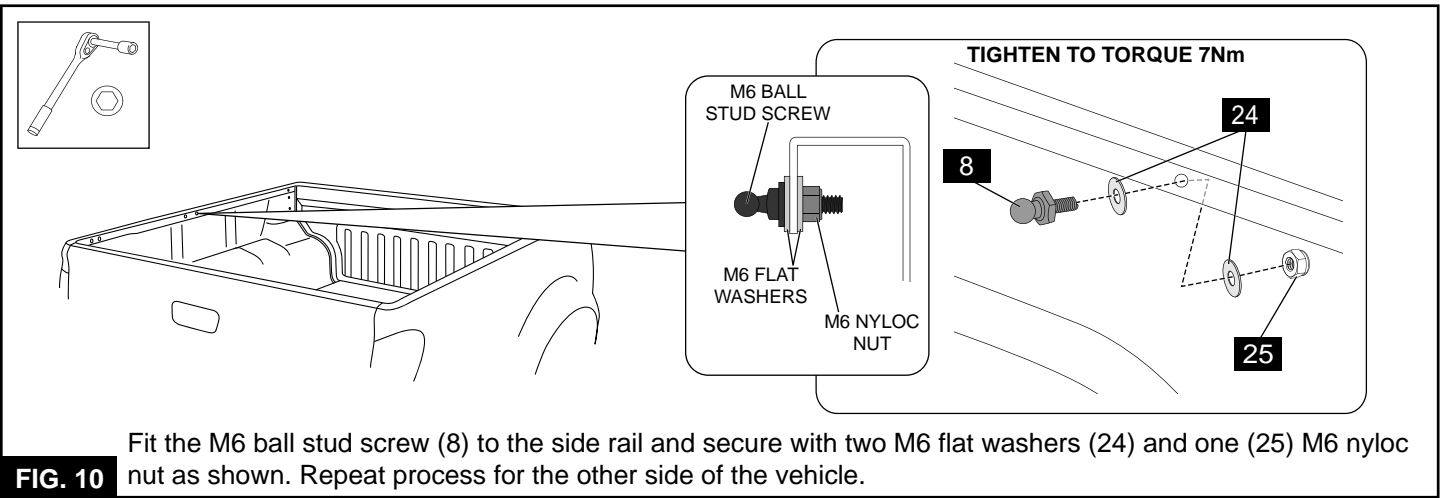

FIG. 10 Fit the M6 ball stud screw (8) to the side rail and secure with two M6 flat washers (24) and one (25) M6 nyloc nut as shown. Repeat process for the other side of the vehicle.

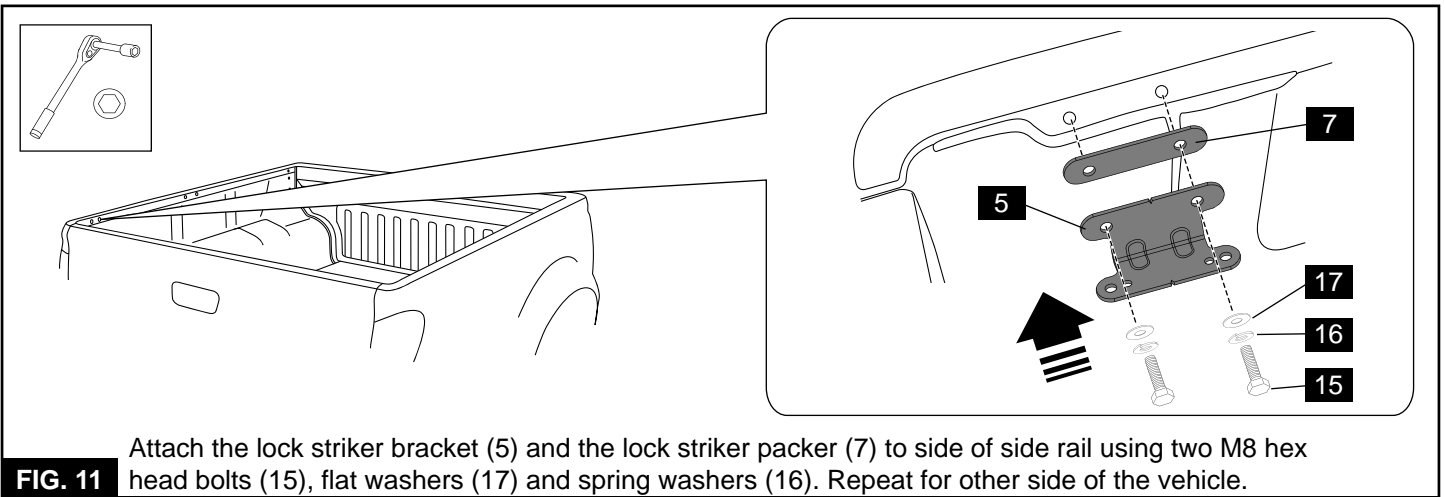

FIG. 11 Attach the lock striker bracket (5) and the lock striker packer (7) to side of side rail using two M8 hex head bolts (15), flat washers (17) and spring washers (16). Repeat for other side of the vehicle.

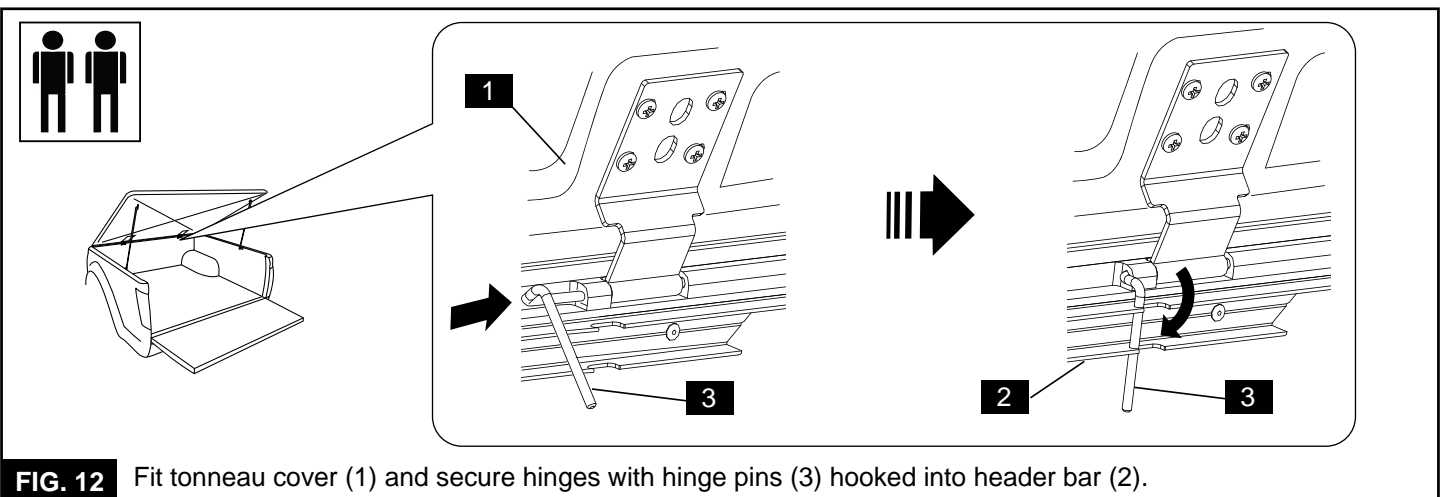
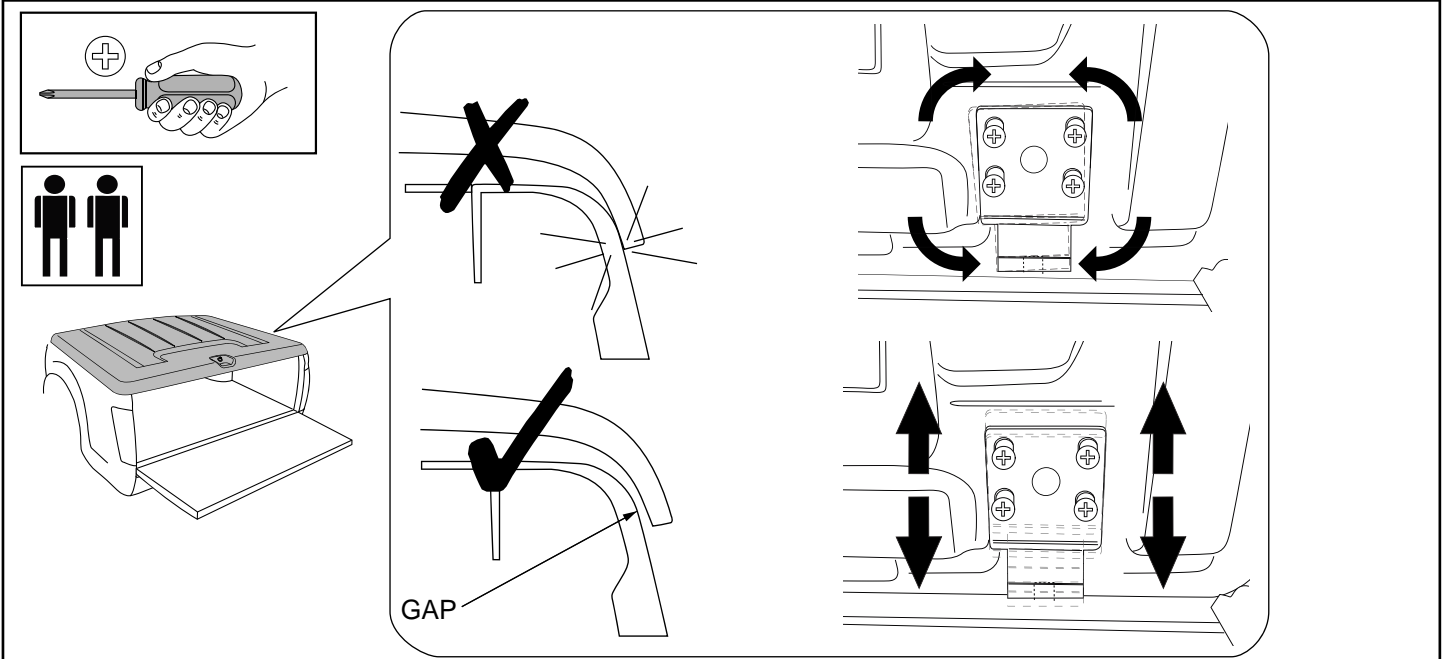

FIG. 12 Fit tonneau cover (1) and secure hinges with hinge pins (3) hooked into header bar (2).



Check clearance of tonneau cover to vehicle rear corners. Ensure the tailgate is open and close tonneau cover. Check clearances at both rear corners between tonneau cover and sheet metal, gaps should be consistent and at least 2mm. If tonneau cover is touching sheet metal or gaps are not even, adjustment may be required.

ADJUSTMENT:

Do this with 2 people, tonneau cover closed and tailgate open. Loosen all screws holding latches and hinges inside tonneau cover. Manually position tonneau cover centrally on tub ensuring even clearances at both rear corners. Hold the tonneau cover in this position and tighten hinge screws.

FIG. 13

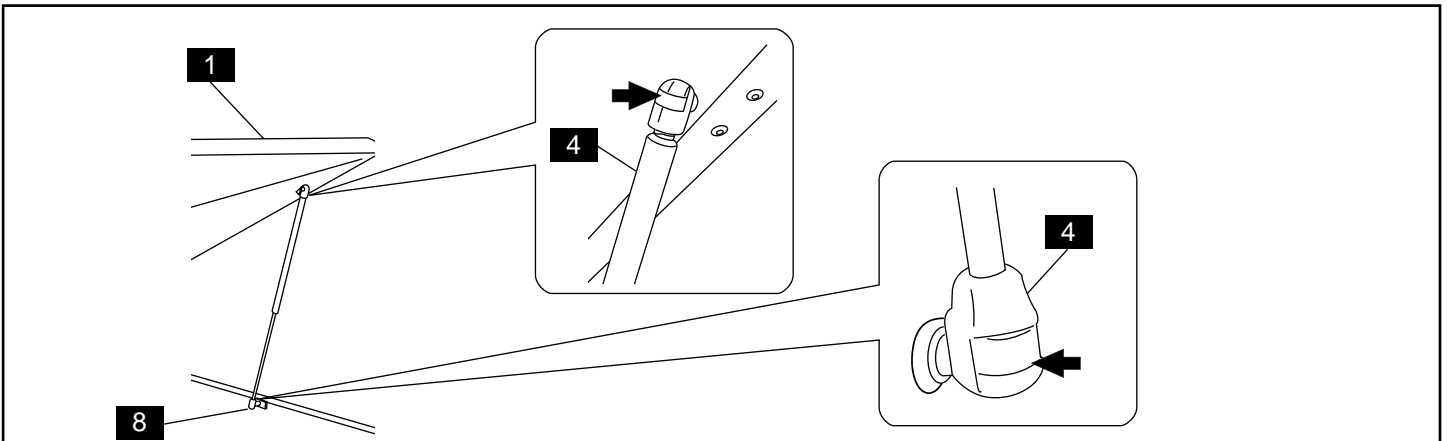
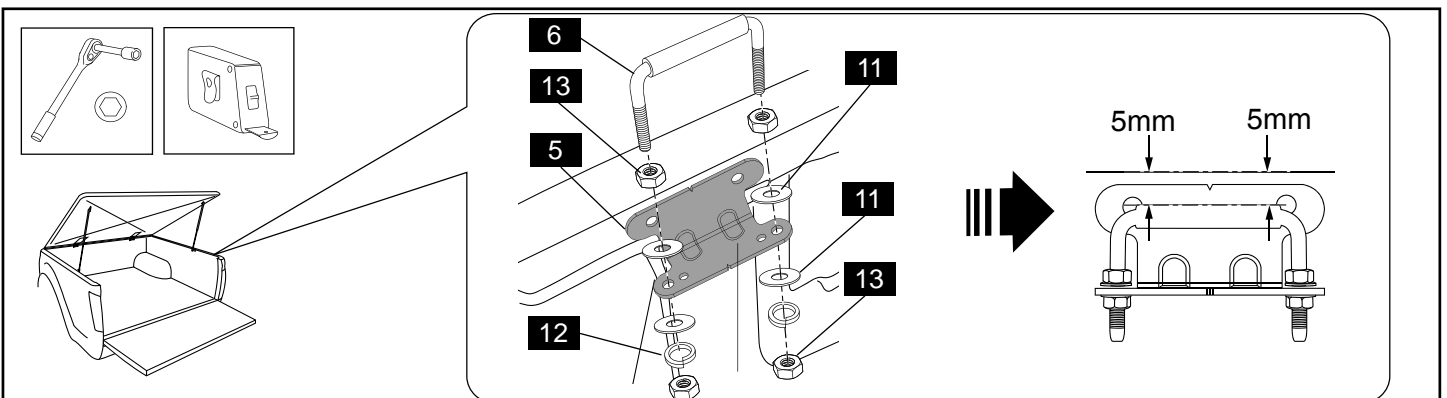

FIG. 14 Attach gas struts (1) by clipping them into place. Ensure narrow end (2) mounts to the vehicle.



Assemble striker U-bolt (6), M6 small flat washers (11), M6 stainless spring washers (12) and M6 stainless hex nuts (13) onto lock striker bracket (5). Adjust so the top of the striker U-bolt (6) is 5mm down from the top of the side rail. Tighten ensuring the 5mm to the top of the side rail is maintained.

FIG. 15

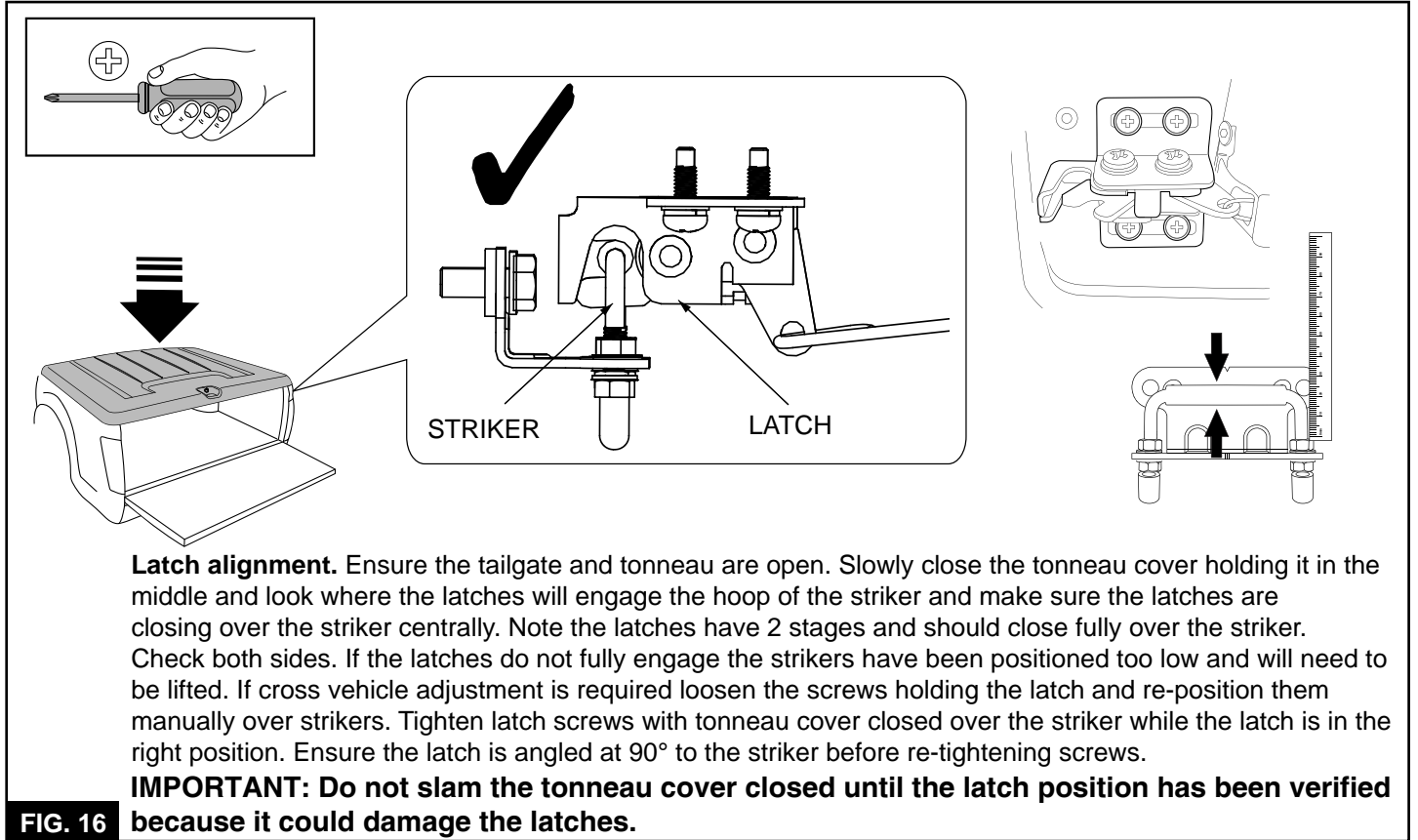

FIG. 16

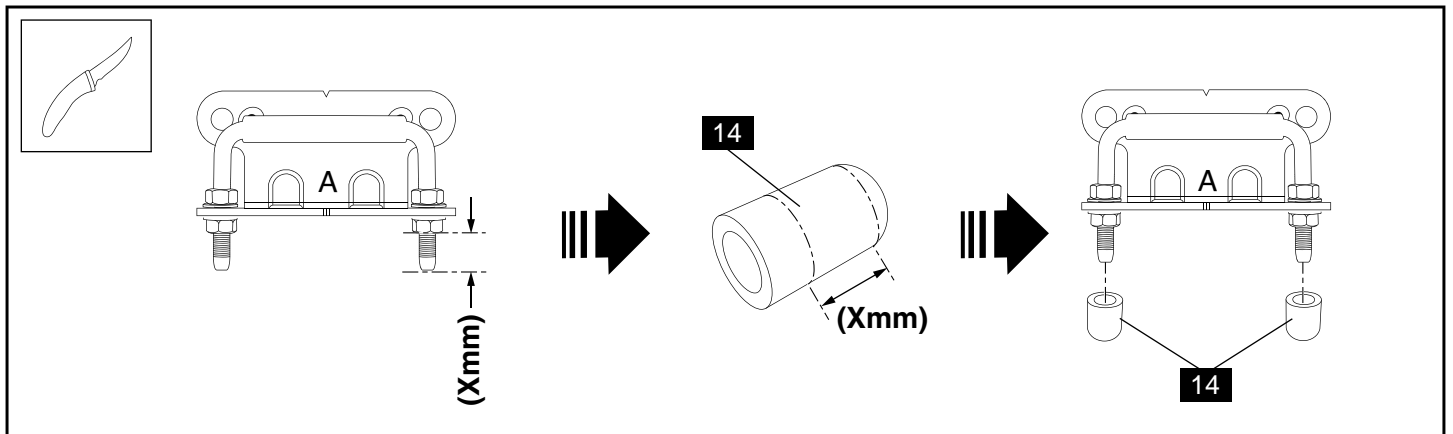

FIG. 17

Measure the length of exposed thread (Xmm) from bottom of the nut to the end of the thread. Measure length (Xmm) on the rubber thread cap (14) and cut to length. Repeat for four thread caps and fit to threads.

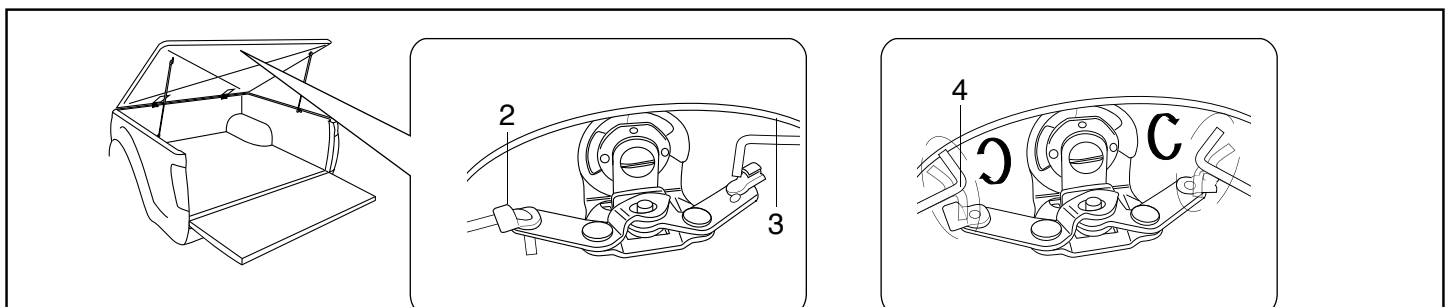

FIG. 18

Push button lock operation. Open tonneau cover, manually close latches and depress push button lock, both latches should open immediately. If latches do not open you may need to adjust the length of pull rods inside tonneau cover. To do this remove inspection cover by removing the two scrivenets and rotating it clockwise. Release plastic retainer clips (2) and unclip pull rods (3), do one at a time. If pull rods are too long they can be shortened by twisting clockwise. If too short they can be lengthened by twisting anti-clockwise. After a couple of turns put pull rods back into position and check operation of push button lock, adjust until lock operation is good.

REMOVAL OF TONNEAU COVER

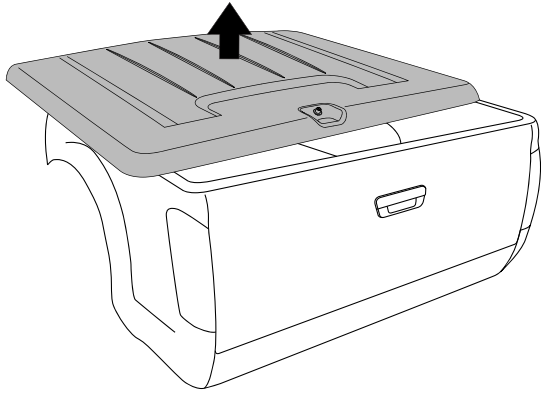

FIGURE 1

1. Open tonneau cover, Detach gas strut (1) by inserting a small screwdriver and adjusting the spring clip (2) on the gas strut (1). Refer to figure 2.
NOTE: Do not remove the spring clip. only a small amount of levering is required to detach.

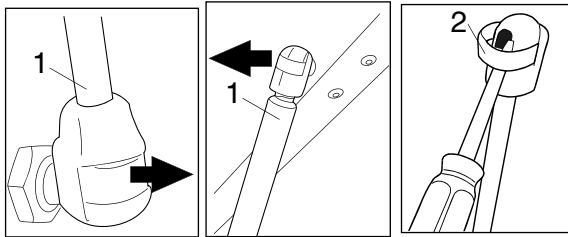
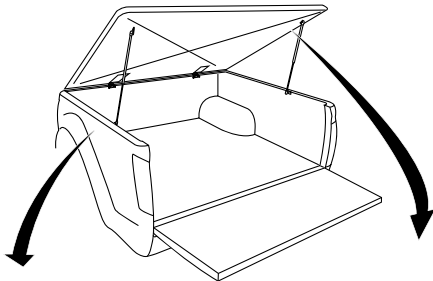

FIGURE 2

NOTE: 2 people are required to lift and remove the tonneau cover from the vehicle.

2. Remove hinge pins (1) and remove tonneau cover (2). Refer to figure 3.

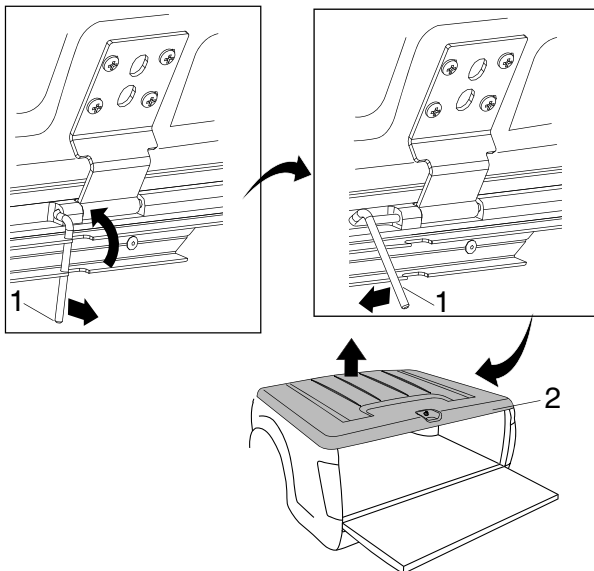

FIGURE 3

REPLACEMENT OF TONNEAU COVER

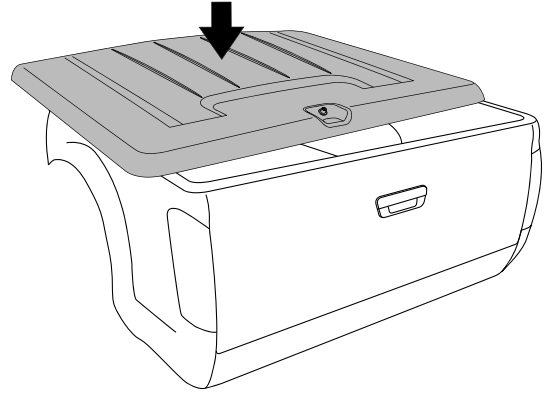

FIGURE 4

NOTE: 2 people are required to lift and fit the tonneau cover onto the vehicle.

1. Fit tonneau cover (2) and secure hinges with hinge pins (1). Refer to figure 5.

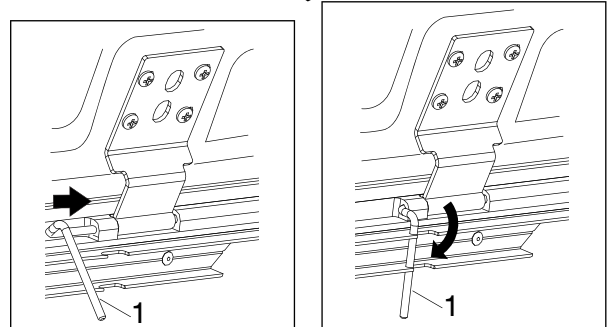
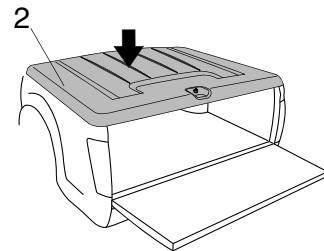

FIGURE 5

2. Attach gas struts (2) by clipping into place. Ensure narrow end (1) mounts to the vehicle. Refer to figure 6.

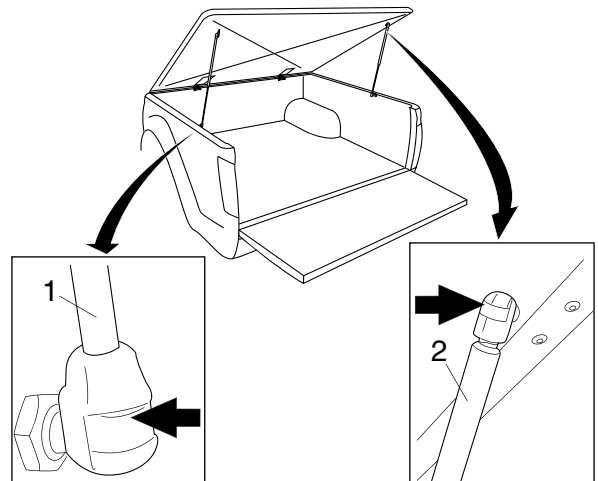

FIGURE 6

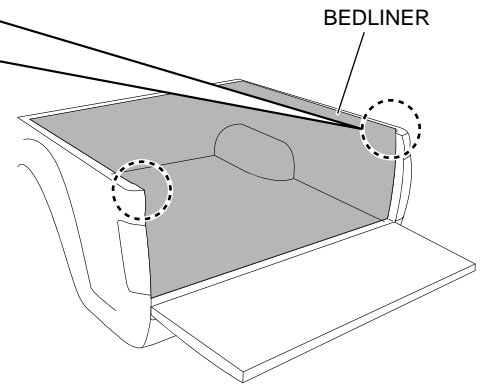
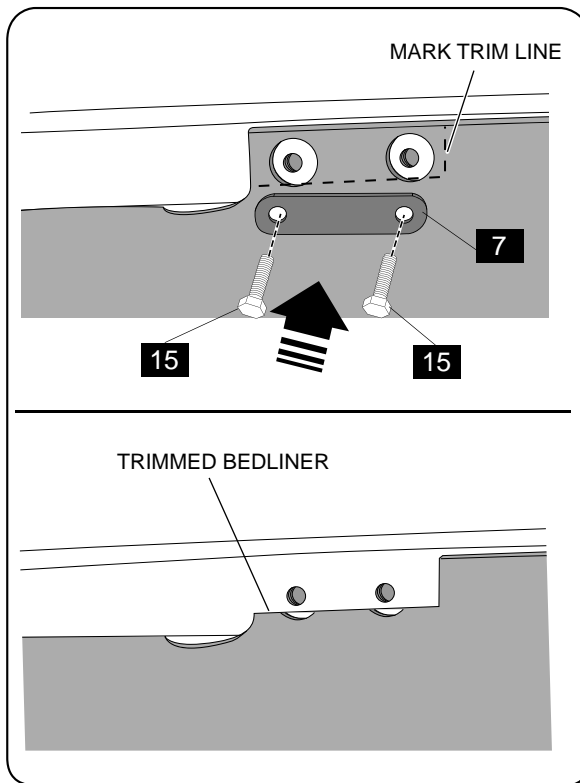
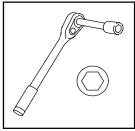

FIG. 19 Screw the striker packer (7) on top of the tub liner with M8 bolts (15). Mark the bed liner around the packer. Remove the packer (7). Cut the tub liner as shown using die grinder or Dremel. Repeat for the opposite side.