

HARD TONNEAU COVER 3 PIECE INSTALLATION INSTRUCTIONS Mitsubishi Triton MQ 2015 ~

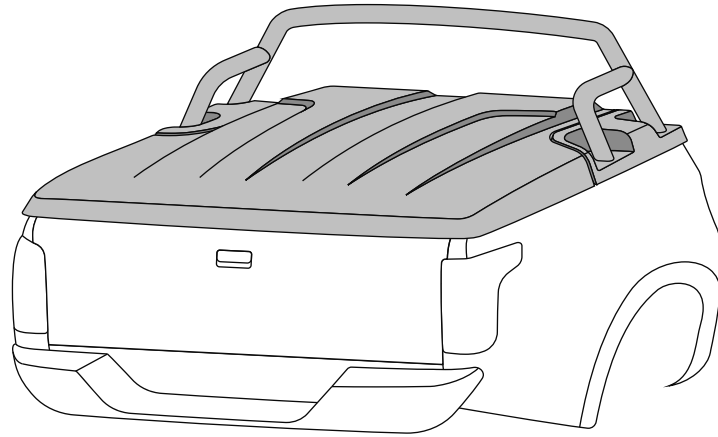

INSTALLATION TIME: 1.5 Hours (Approximately)

IMPORTANT!

- Read instructions carefully before installation.
- It is strongly recommended that installation is conducted by an authorized dealer.
- This product must be installed exactly as specified in these instructions. Failure to do so may result in improper fit and/or retention/failure of components.
- Recommend installation by two people. (four people will be required to lift Canopy)

CARE INSTRUCTIONS:



Clean Canopy with a mild detergent and water solution.



Do not use abrasive cleaners or solvents.

PERSONAL PROTECTIVE EQUIPMENT:



Mask



Rubber Gloves



Goggles





Hearing Protection

RECOMMENDED TOOL LIST - (Not Supplied in Kit)





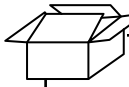
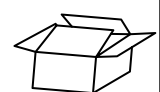
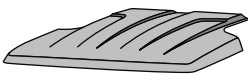
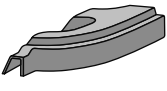
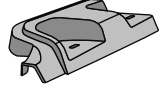
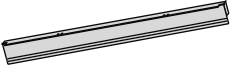
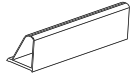





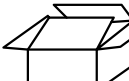
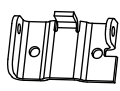
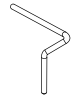
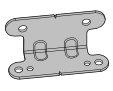

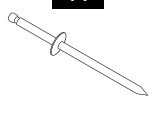









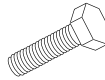

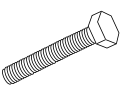
- Phillips Head Screwdriver
- Sockets 10, 12 & 13mm, Extension Bar and Driver
- Spanners 10, 12 & 13mm
- Silicon Dispensing Gun
- Clear Non Acetic Silicon (Neutral Cure)
- Spray Bottle (25% isopropyl Alcohol & 75% Water)
- Torque Wrench - 0-20Nm
- Scissors
- Non Permanent Marker
- File or De-burring Tool
- Drill and Ø3mm Ø5.5mm Ø6mm Ø6.5mm Ø8.5mm Drill Bits
- Masking Tape
- Hammer & Centre punch
- Cleaning Cloths / Rags
- Steel Rule and Tape Measure
- Locktite 243

PARTS CHECK SHEET

PARTS IN MAIN CARTON

	1	2	3	4	5	
						
Tonneau Cover Qty - 1	LHS Infill Panel Qty - 1	RHS Infill Panel Qty - 1	Header Bar Qty - 1	Header Bar Seal (MISC2229-9) Qty - 1	Lock Keys (Attached to Hardware Kit) Qty - 2	Fitting Kit Qty - 1

PARTS IN FITTING KIT

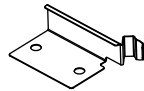
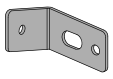
	6	7	8	9	10	11
						
Hinge Bracket (CLIP2720PC) Qty - 2	Hinge Pin (CLIP2032) Qty - 2	Striker Bracket (CLIP2874PC) Qty - 2	Jacking Bracket (CLIP2049-1) Qty - 2	Scrivet (FAST0086) Qty - 2	Pop Rivet (FAST0609) Qty - 7	
12	13	14	15	16	17	
						
Striker U-Bolt (LOCK0006) Qty - 2	Alcohol Wipe (MISC0052) Qty - 2	Primer Stick (MISC1365) Qty - 2	Rust Inhibitor (MISC2776) Qty - 1	M6 S/S Nylock (NUTS0016) Qty - 6	M6 S/S Hex Nut (NUTS0161) Qty - 8	
18	19	20	21	22	23	
						
M8 S/S Hex Nut (NUTS0217) Qty - 2	M8 S/S Nylock (NUTS0242) Qty - 6	M6x20 Hex Head Bolt (SCRW0028) Qty - 4	M8x20 Hex Head Bolt (SCRW0665) Qty - 6	Ball Strut Screw (SCRW0724) Qty - 2	M8x50 Hex Head Bolt (SCRW0789) Qty - 6	
24	25	26	27	28	29	
						
Gas Strut (STRT0006-2) Qty - 2	M6 S/S Spring Washer (WASH0103) Qty - 4	M6 Small S/S Flat Washer (WASH0153) Qty - 16	M6 Large S/S Flat Washer (WASH0169) Qty - 4	M8 Large S/S Flat Washer (WASH0171) Qty - 20	Tape 90x90 (TAPE0392) Qty - 2	
30	31	32	33	34	35	
						
Tape 6x300 (TAPE0697) Qty - 1.0M	M8x25 Allen Head Bolt (SCRW0623) Qty - 4	Fitting Instruction (FIT-TC0358c) Qty - 1	Rubber Cap (MISC2532) Qty - 4	Hinge Pin Retainer (CLIP2717-1) Qty - 2	Corner Bracket (CLIP3529PC) Qty - 2	

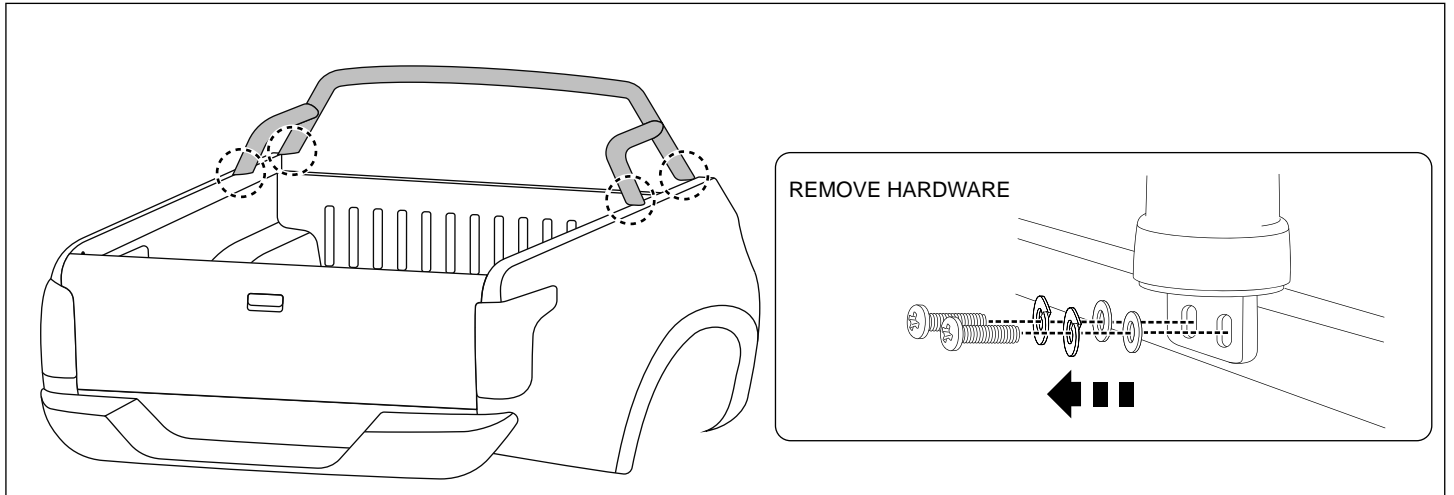

Diagram #1

1. Remove the hardware holding the sports bar feet to the tub and carefully remove the sports bar. Retain all hardware. **See Dia #1.**

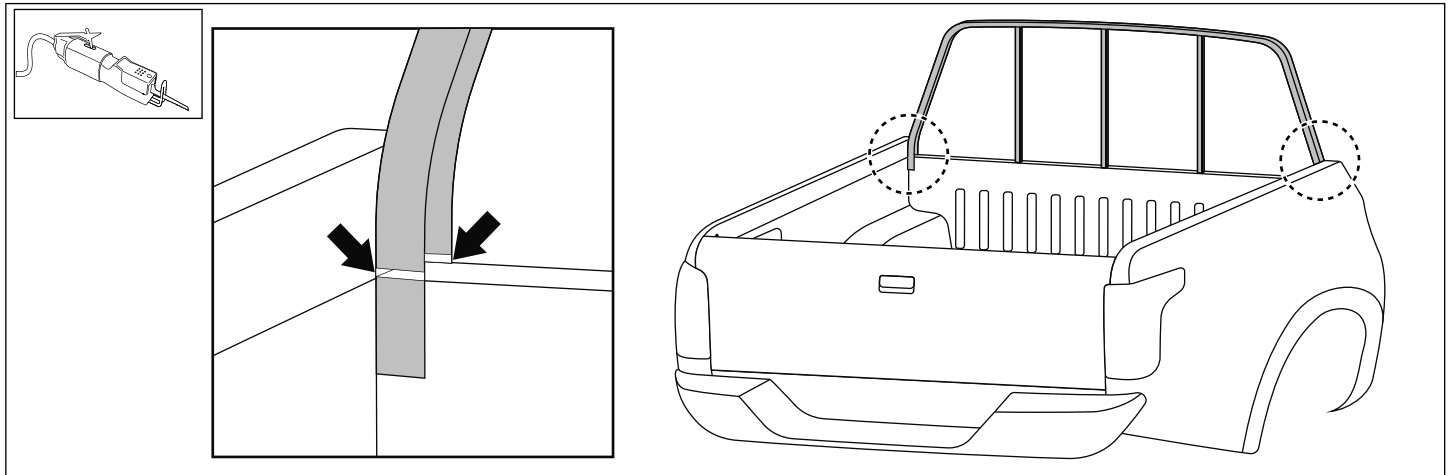

Diagram #2

2. Apply masking tape to the front rail of the tub. Completely cut through the two outer cabin guard bars flush with the front tub rail. **See Dia #2.**

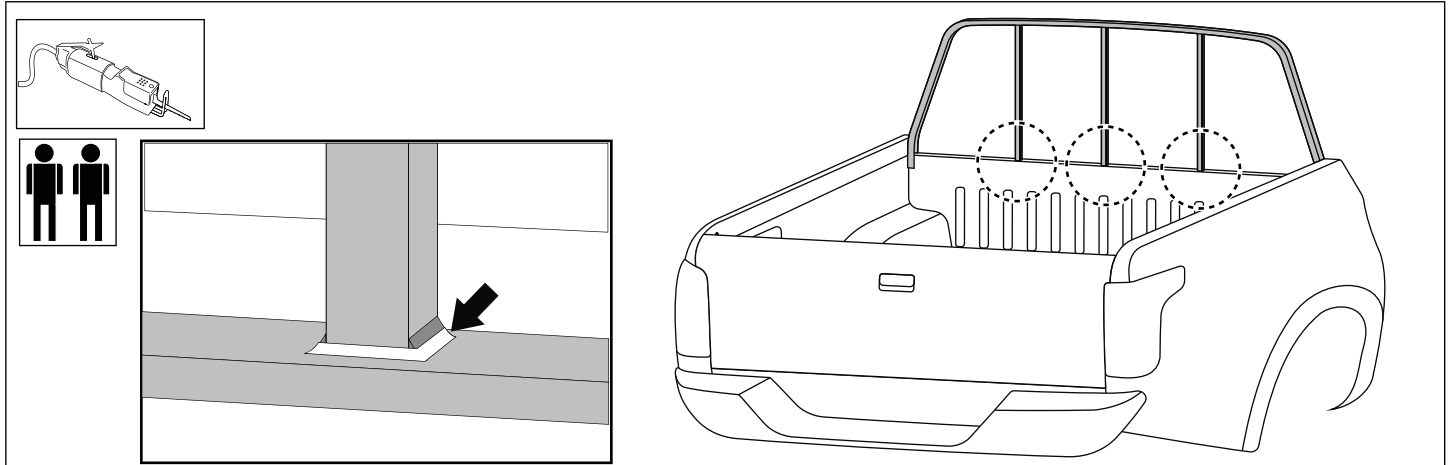

Diagram #3

3. Completely cut through the three center cabin guard bars flush with the front tub rail. Remove cabin guard. Remove any burrs and apply paint primer to bare metal surfaces. **See Dia #3.**

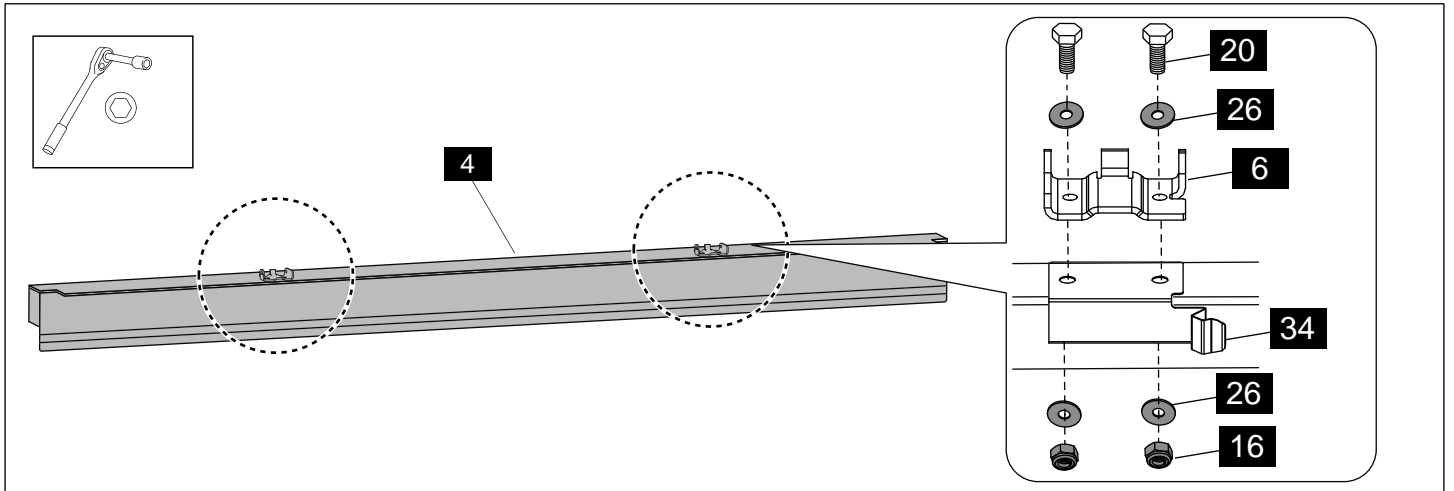

Diagram #4

4. Secure the hinge bracket and hinge pin retainer to the header bar using M6 bolts, M6 flat washers and M6 nylock nuts. See Dia #4.

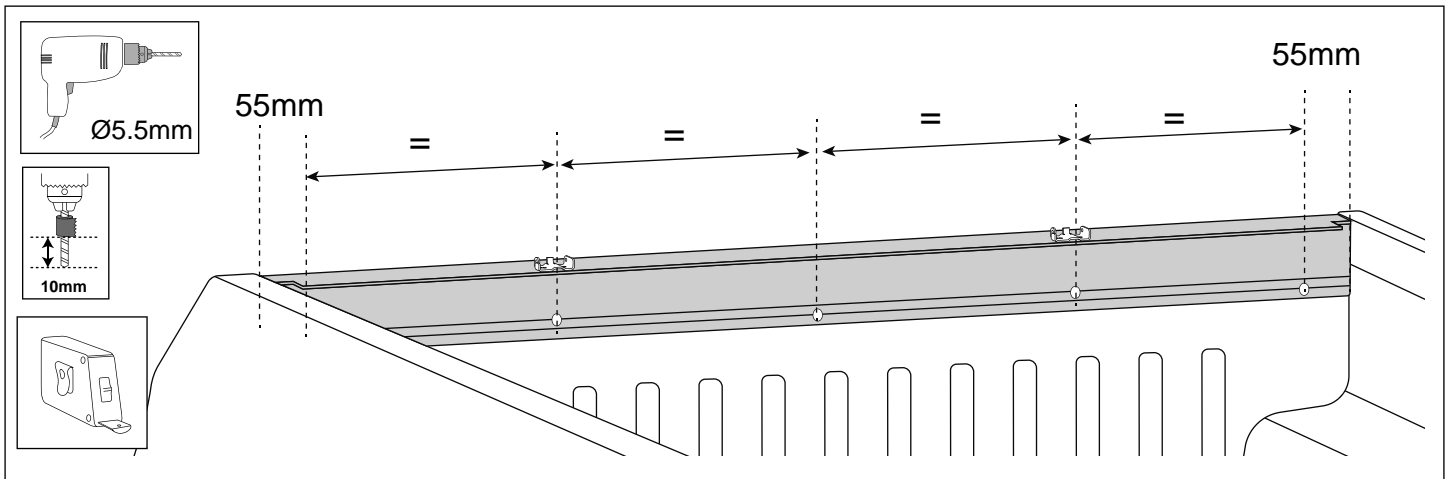

Diagram #5

5. Mark a vertical line on the header bar crossing the grooves 55mm from the side rail, mark another four lines equally spaced. Using 5.5mm drill bit, drill five holes through the header bar and front tub rail staggering the holes on the upper and lower grooves of the header bar. Remove header bar and apply rust inhibitor to the drilled holes on the front tub rail. See Dia #5.

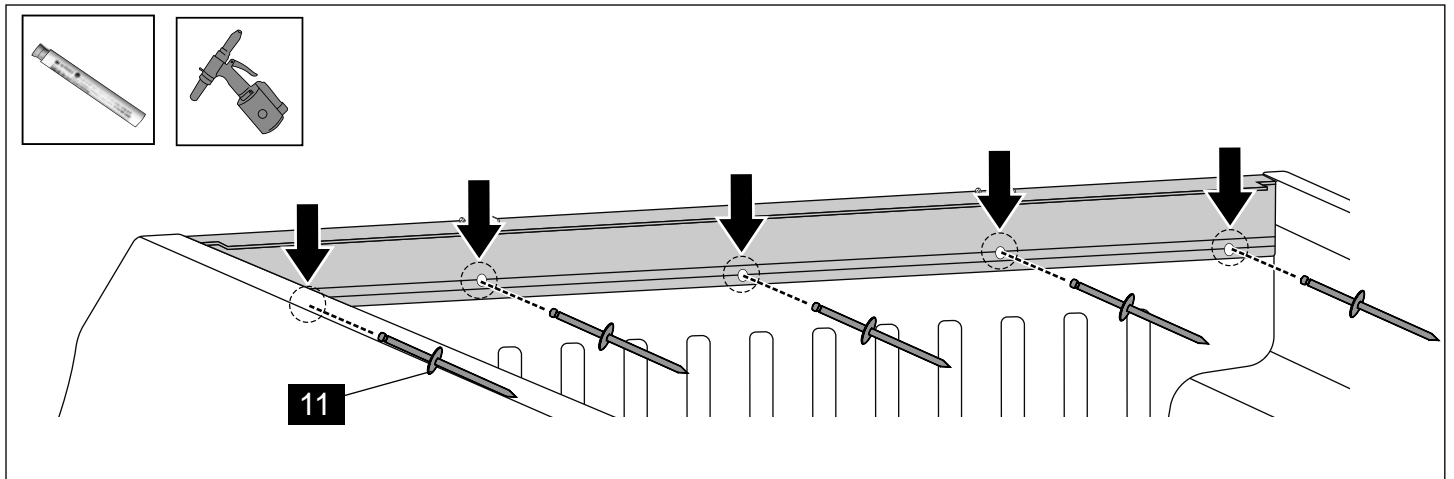

Diagram #6

6. Apply primer to the front top tub rail (allow five minutes to dry). Peel the backing tape liner from the header rail. Secure the header rail bar to the front tub rail with rivets. See Dia #6.

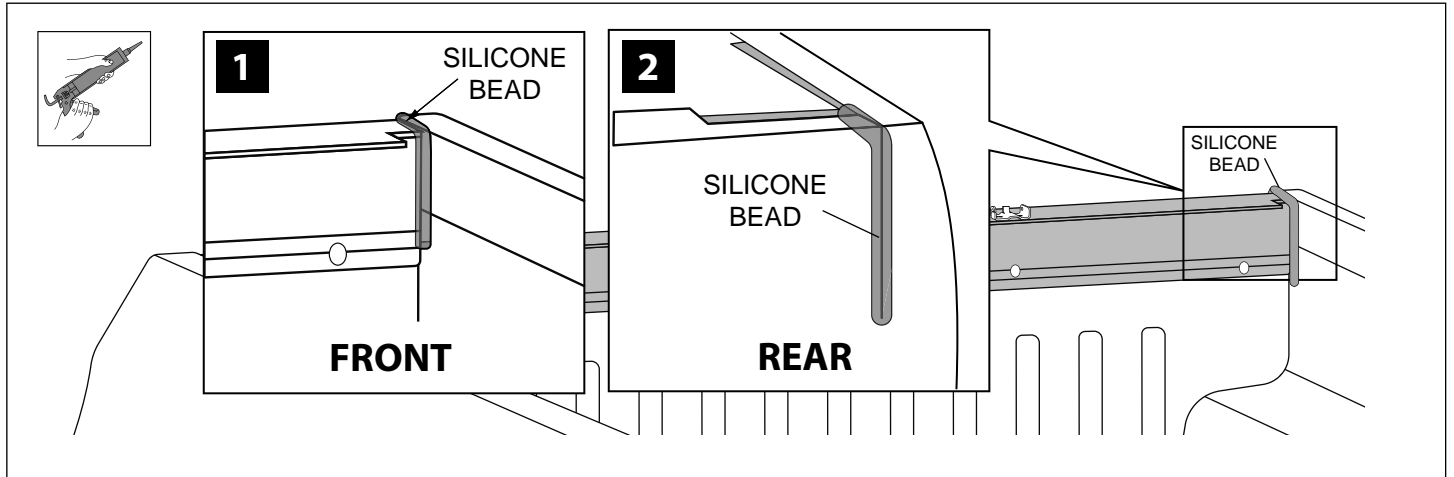

Diagram #7

7. Apply bead of silicone along the end of the header bar between the join in the sheet metal and down the back, as illustrated above. Repeat on the other side of the tub. **See Dia #7.**

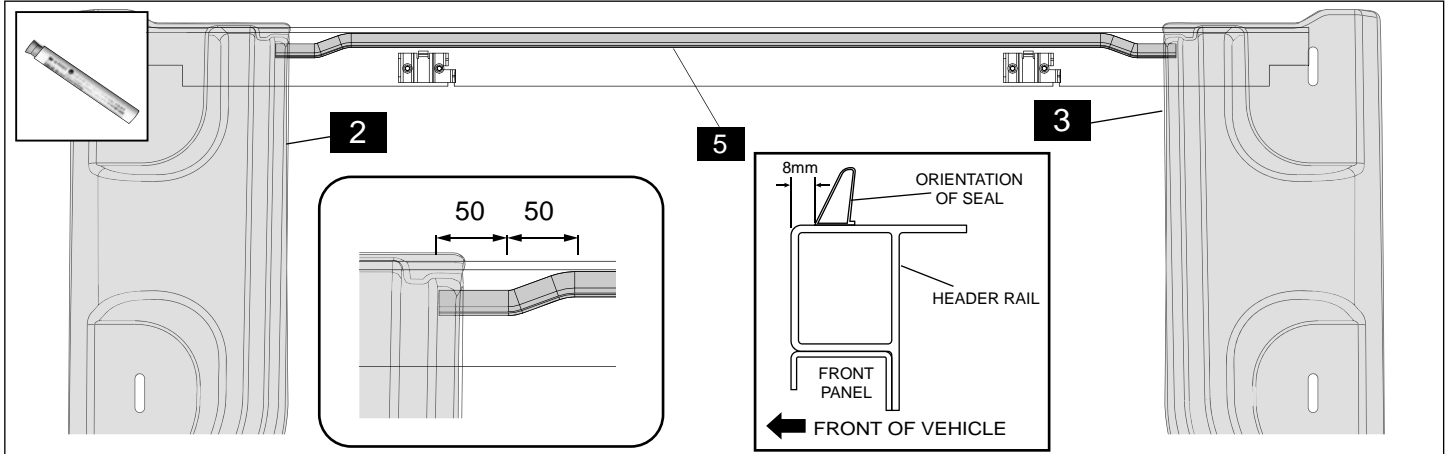

Diagram #8

8. Apply primer to the top of the header rail, where the bulb seal will be placed (allow five minutes to dry). Place the two infill panels on the tub as shown. Peel the backing tape liner from the bulb seal. Adhere the bulb seal to the top of the header rail, 8mm from the front face of the header rail. At each end form the seal as shown to allow it fit into the cutout in the infill panels. **See Dia #8.**

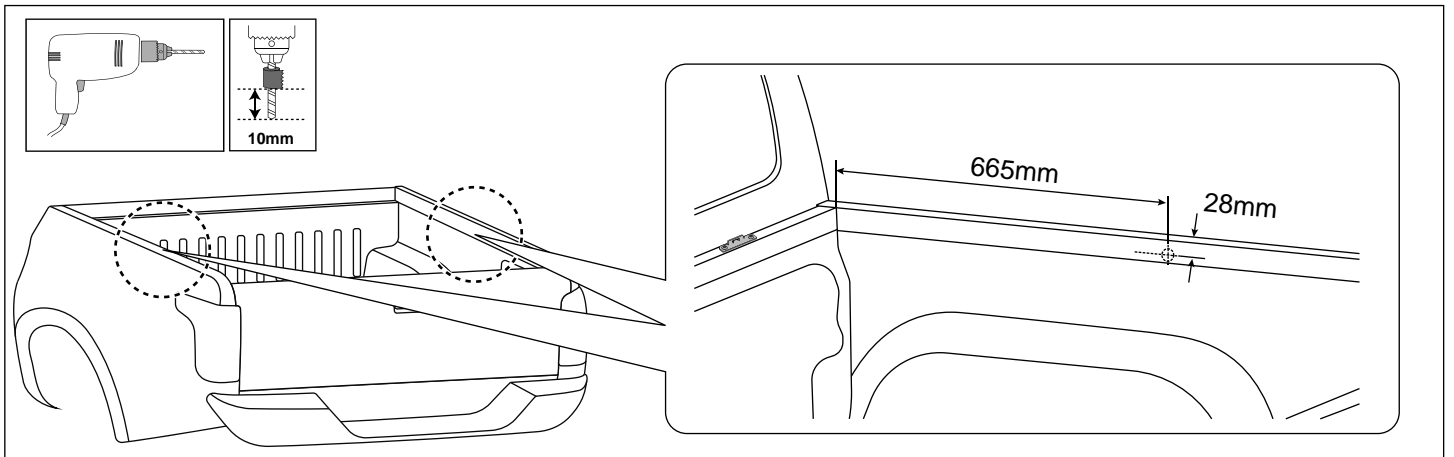

Diagram #9

9. Mark the hole centre 665mm from the inside face of the front tub rail and 28mm down from the top edge of the side rail. Drill the marked hole location using a 3mm pilot drill bit and then a 8.5mm drill bit. De burr hole and apply rust inhibitor. Repeat for other side. **See Dia #9.**

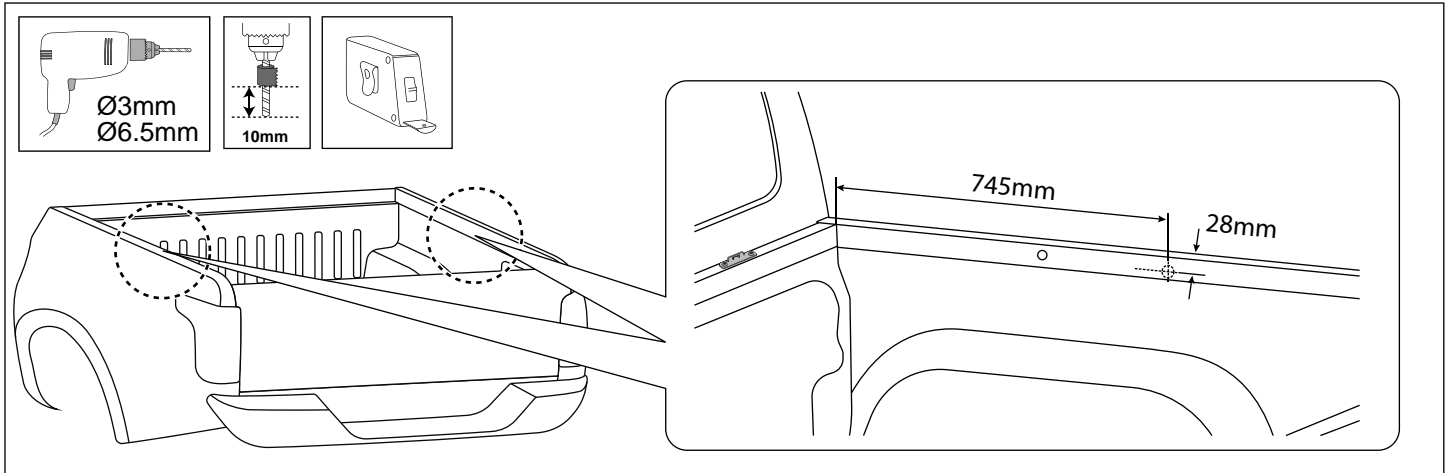

Diagram #10

10. Mark the hole centre 745mm from the inside face of the front tub rail and 28mm down from the top edge of the side rail. Drill the marked hole location using a 3mm pilot drill bit and then a 6.5mm drill bit. De burr hole and apply rust inhibitor. Repeat for other side. **See Dia #10.**

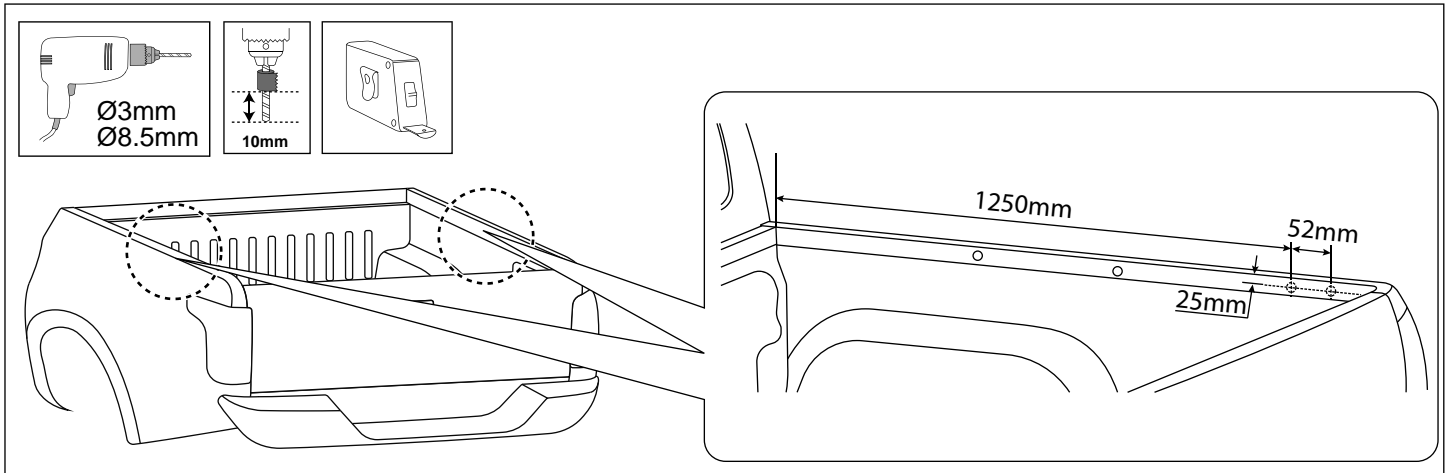

Diagram #11

11. Mark the hole centre 1250mm from the inside face of the front tub rail and 52mm from that point. Mark 25mm down from the top edge of the side rail. Drill the marked hole location using a 3mm pilot drill bit and then a 8.5mm drill bit. De burr hole and apply rust inhibitor. Repeat for other side. **See Dia #11.**

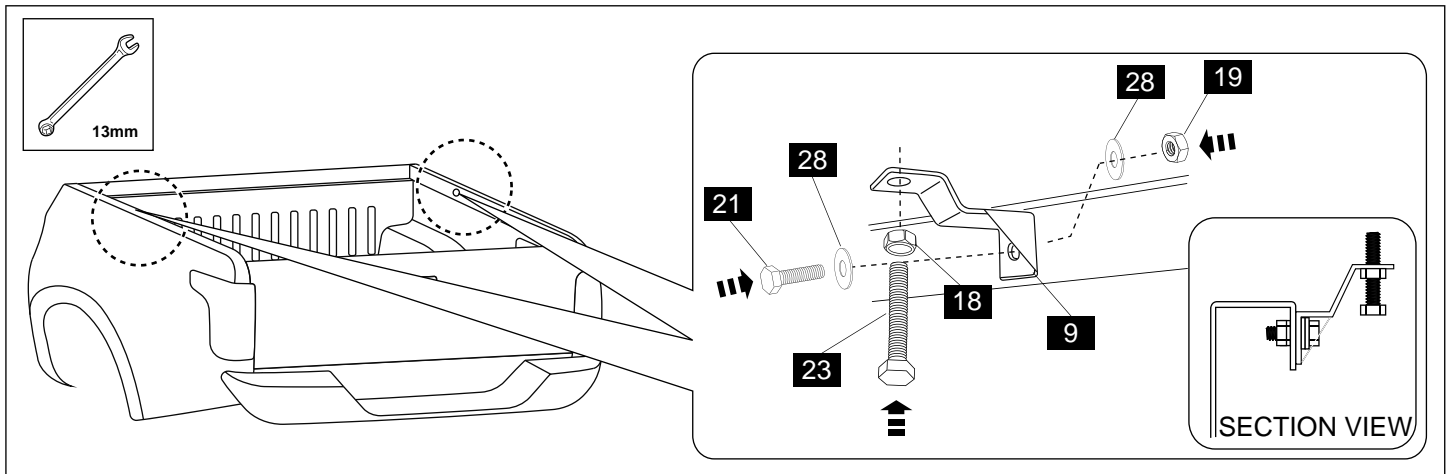

Diagram #12

12. Secure the jacking bracket to the tub using M8 screw, flat washers and M8 Nylock nut as shown. Repeat for other side. **See Dia #12.**

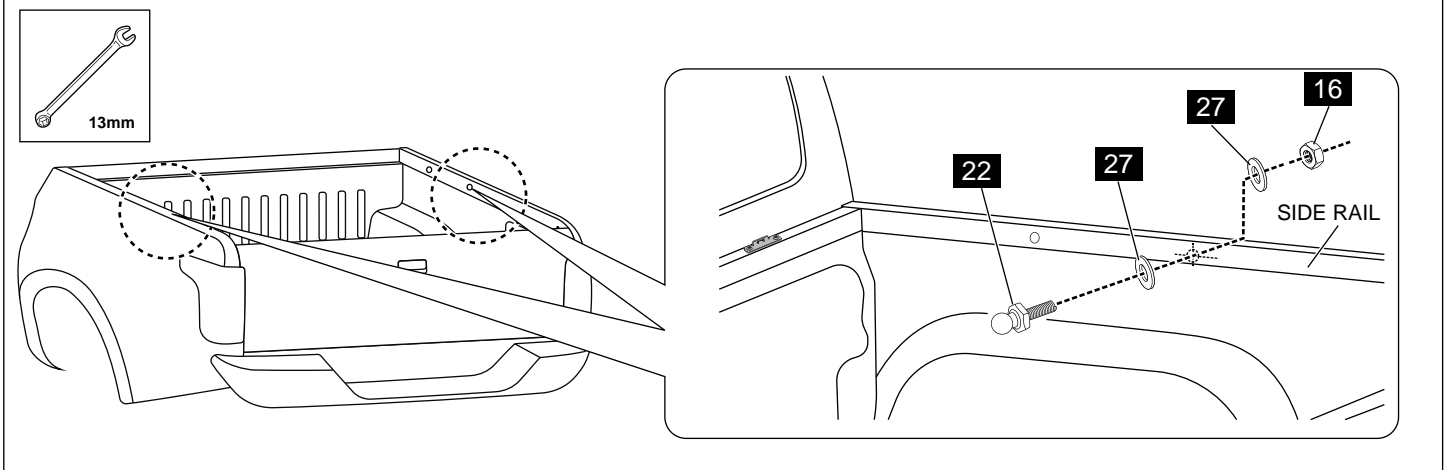

Diagram #13

13. Attach the ball stud screw to the side rail, using two flat washers, and M6 nylock nut as shown (Torque 8Nm). Repeat for other side. **See Dia #13.**

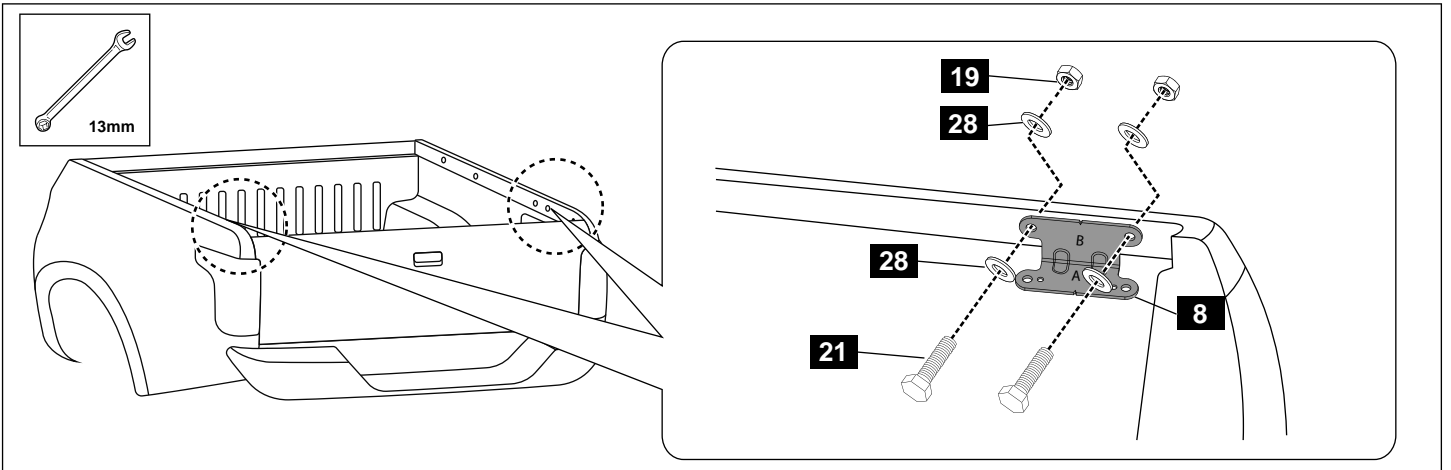

Diagram #14

14. Attach the lock striker bracket to the side rail as shown. Secure to the side rail using two M8 bolts, four flat M8 washers, and two M8 nylock nuts (Torque 22Nm). Repeat for other side. **See Dia #14.**

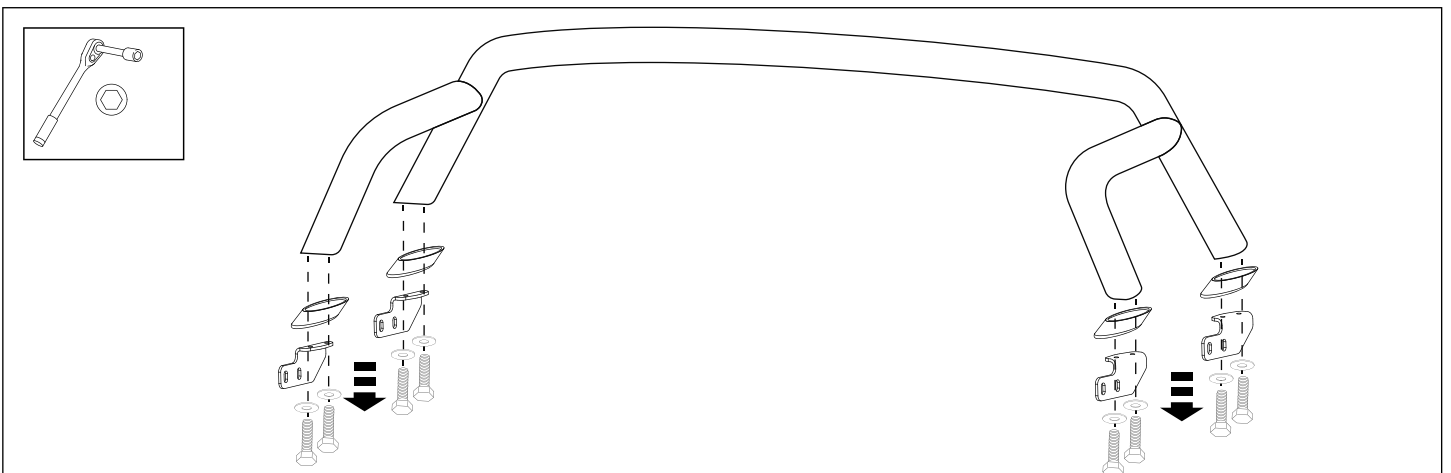

Diagram #15

15. Remove the front and rear brackets and foot cups from the sports bar. Retain all the hardware. Flip the sports bar over and place on a piece of cardboard to avoid damage. **See Dia #15.**

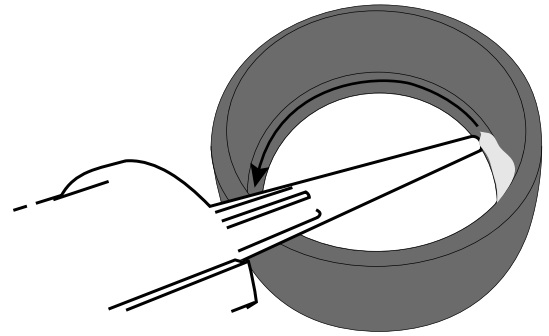
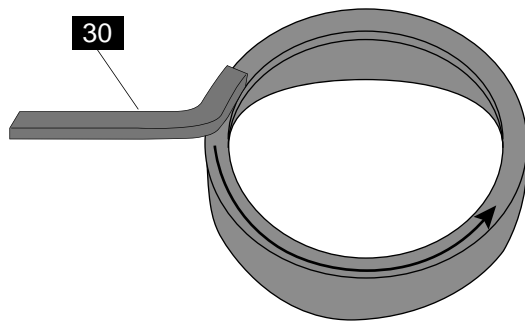
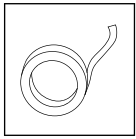
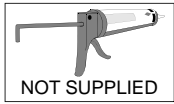

Diagram #16

16. Apply EPDM to the base of foot cups as shown. Ensure the inside of the foot caps is clean. Apply a bead of non acetic silicon (not supplied) around the inside surface of the foot cups. Re-attach foot cups to the sports bar feet to ensure silicon seals foot cups. Ensure silicon does not protrude above foot cups. **See Dia #16.**

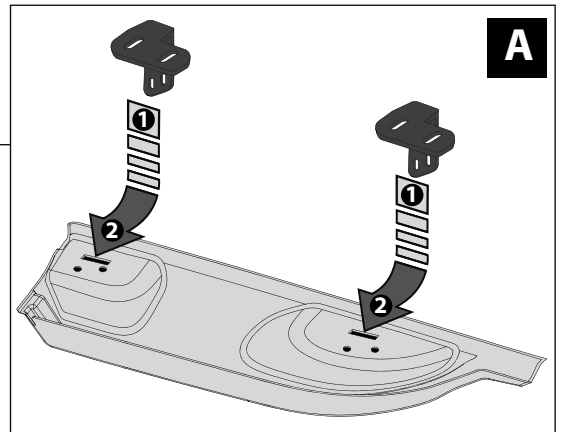
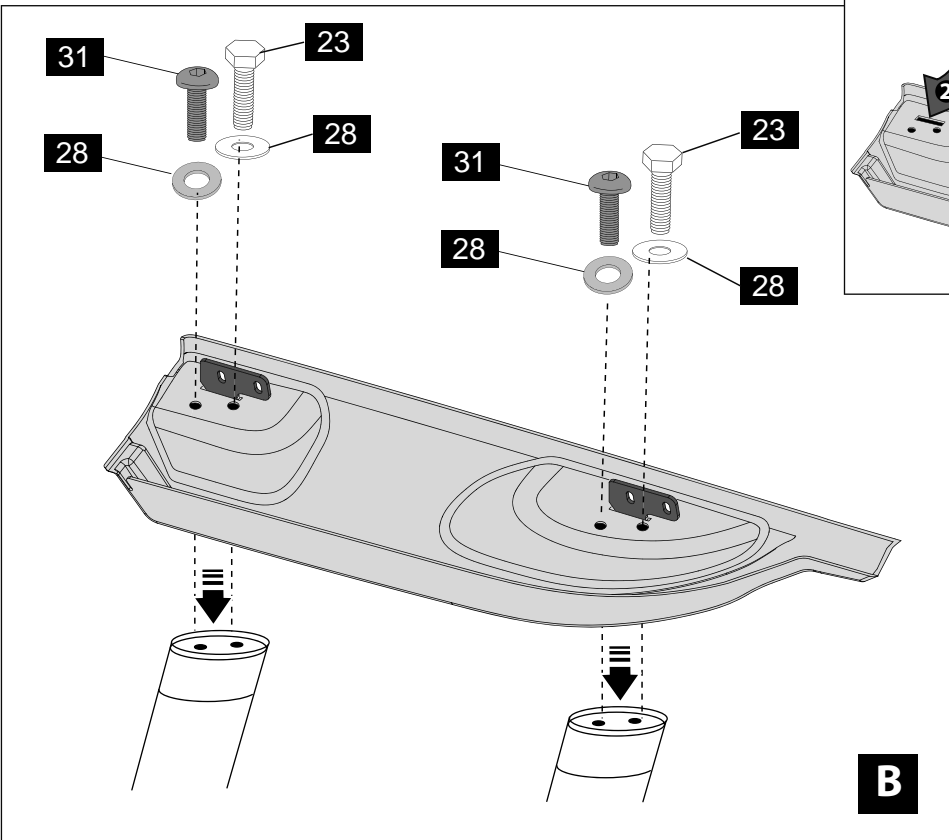
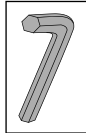
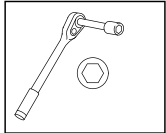

Diagram #17

17. Fit the button head internal hex bolt and flat washer into the sports bar foot as shown. Slide the sports bar foot into the infill panel on top of the sports bar leg and loosely secure the allen key bolt. Repeat for all remaining sports bar feet. Once all the sports bar feet are in place, further secure the assembly by loosely installing the hex head bolts and washers. **Note:** Apply Loctite 243 to the hex head bolts. Place the entire assembly onto the vehicle. Once the infill panels are aligned tighten all the fasteners. Torque the Allen key bolt to 8Nm. **Note:** Tighten the hex head bolts until they contact the infill panel. Do not overtighten. **See Dia #17.**

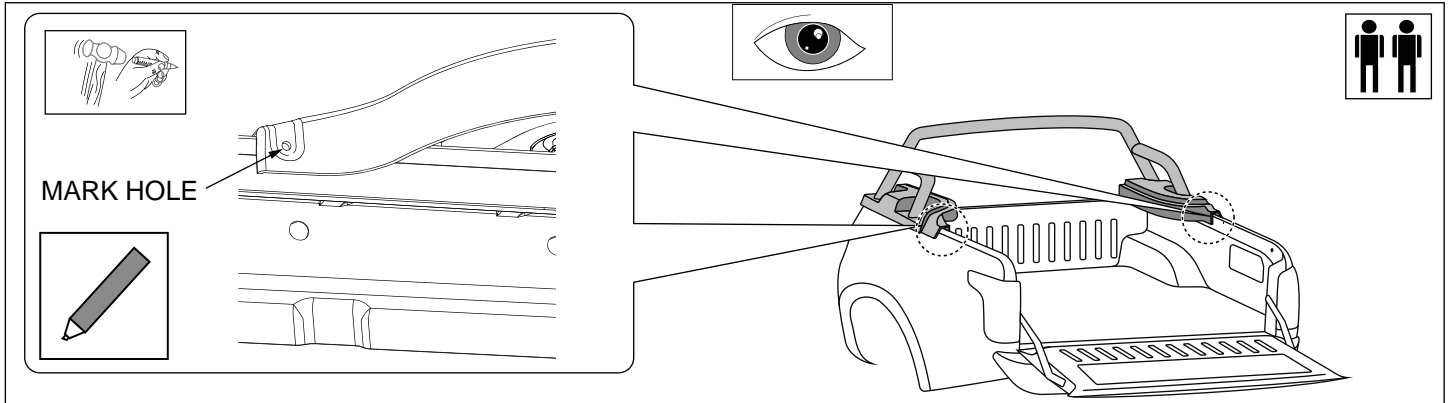

Diagram #18

18. Ensure that the rear of the infill panel is sitting firmly on the side rail of the tub (push down if necessary). Mark and centre-punch the scrivet hole position. Trial fit the anti-abrasive tape (29) onto the bedrail, it's positioned half under the corner piece and half exposed. Repeat process for the other side of the vehicle. Remove the sports bar from the tub. **See Dia #18.**

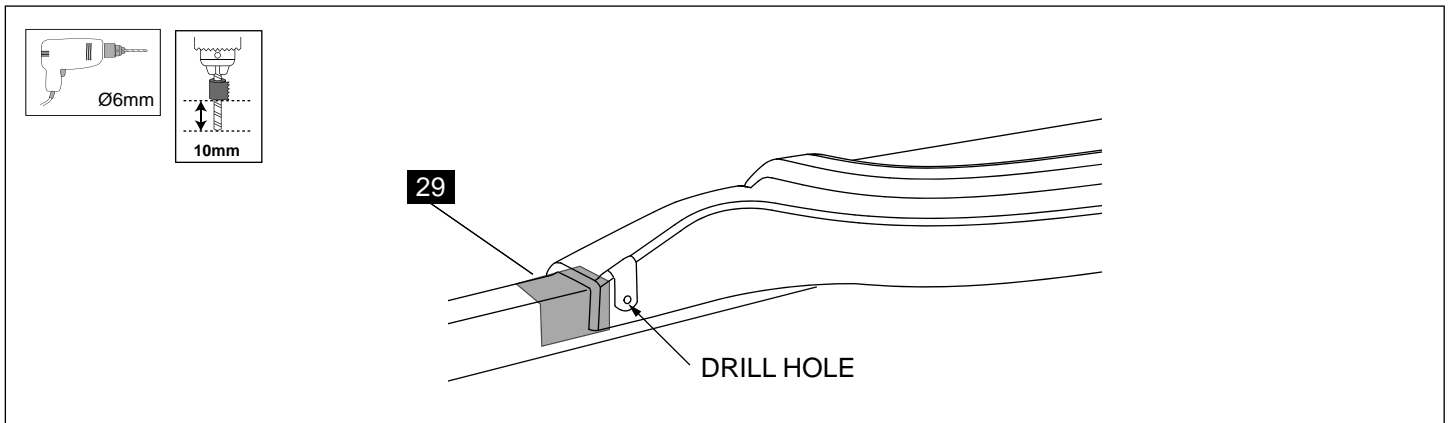

Diagram #19

19. Drill the marked hole with 6mm drill and apply rust inhibitor. Apply the clear tape and ensure there are no air bubbles on the underside. Your hands need to be clean before applying the tape. Repeat for the LHS. **NOTE:** Ensure surfaces are clean and dry before applying abrasive resistant tape. **See Dia #19.**

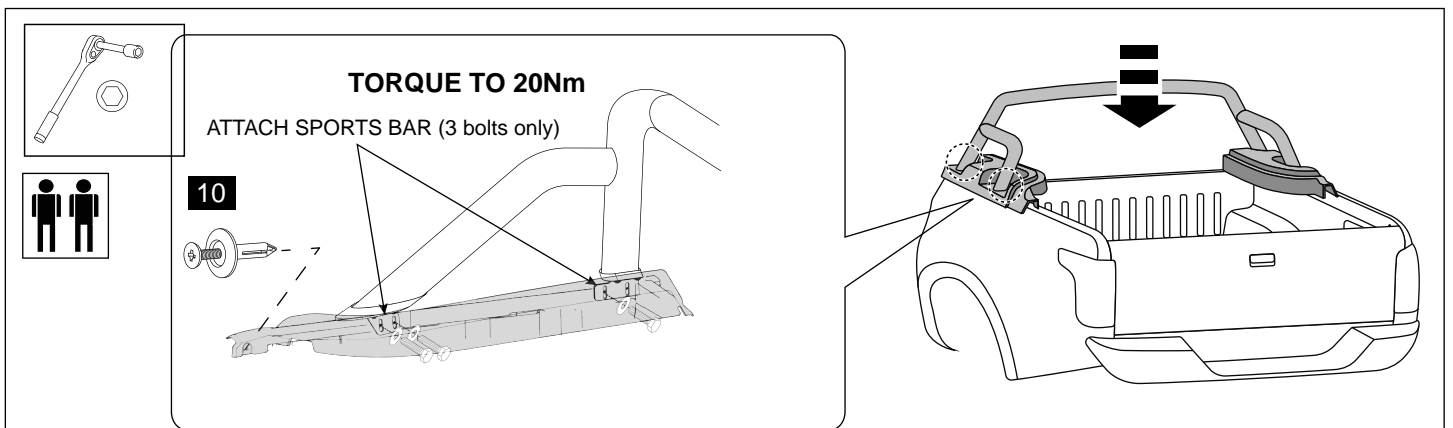

Diagram #20

20. Two people are required for this step. Carefully position the sports bar assembly on the vehicle. Re-attach legs of sports bar with previously removed hardware. Ensure that the sports bar and infill panels are sitting down firmly on the top of the tub bed rails. Pull down on the sports bar to compress the foam seal on the foot cups and attach bar with three (leave front bolt out at this stage) sports bar attachment washers and bolts to torque setting 20Nm into the tub. Secure the infill panel with scrivet. Repeat for the other side of the vehicle. **See Dia #20.**

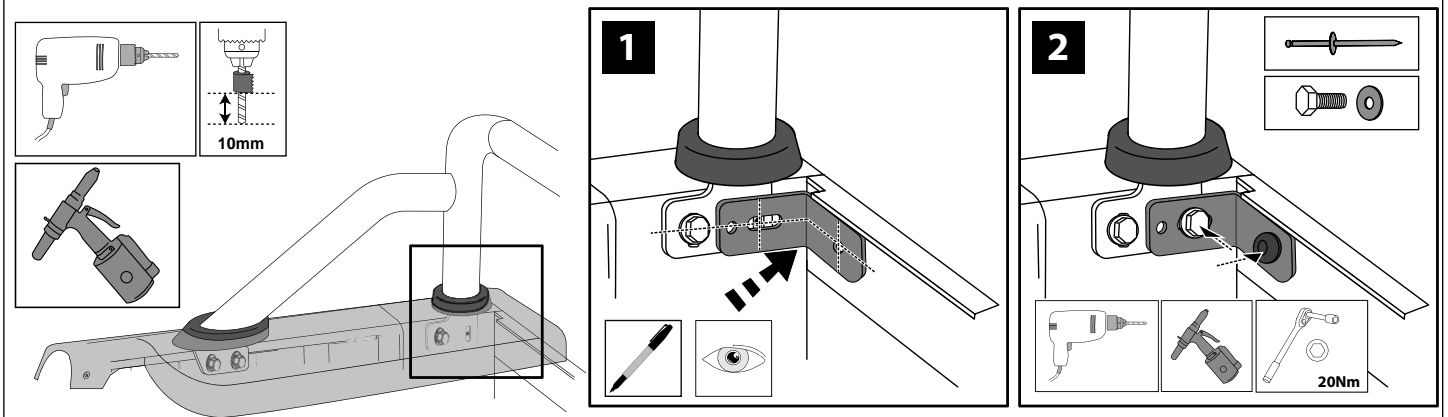

Diagram #21

21. Align the corner bracket with the pre-existing hole in the sportsbar/ tub and mark the hole location on the header bar. Using 5.5mm drill bit, drill a hole through the header bar. Apply rust inhibitor to the drilled hole. Secure the bracket to the header bar with a rivets and a bolt and washer through the sportsbar vehicle tub. Repeat on the other side of the tub. **See Dia #21.**

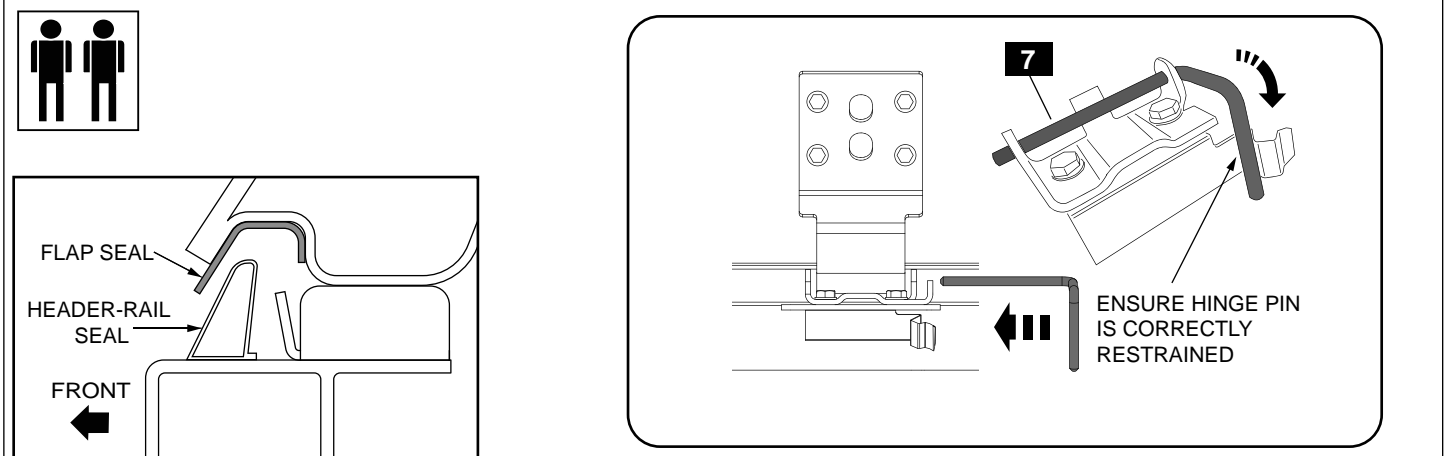

Diagram #22

22. NOTE: Two people are required to carry out fitment of the Tonneau Cover. Carefully lift and fit the tonneau cover (1) to the vehicle. Ensure the hinges sit correctly in the header rail and that the tonneau flap/header rail seals are sitting correctly (check that they are not pushed out of alignment or being pinched by the lid. Secure the tonneau hinges with hinge pins pressed into header bar. **See Dia #22.**

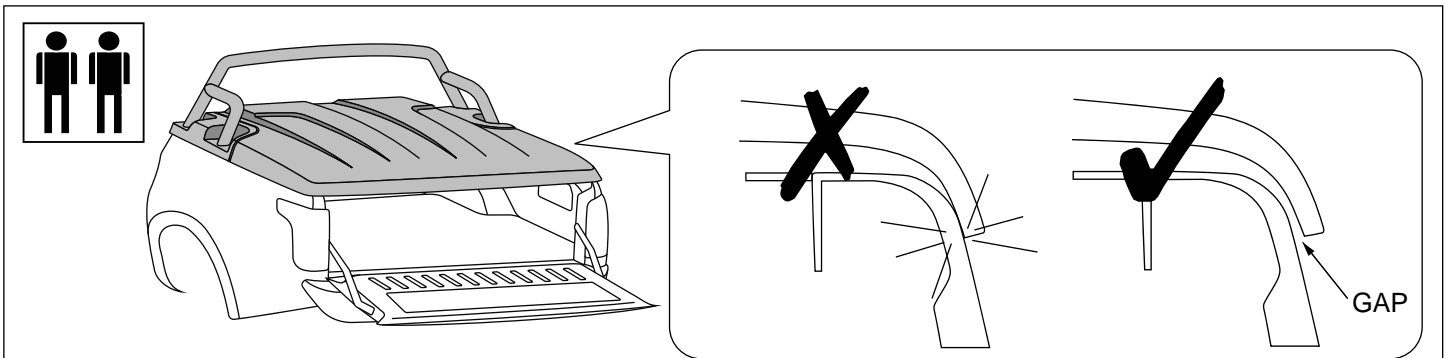

Diagram #23

23. Check clearance of tonneau cover to vehicle rear corners. Ensure the tailgate is open and close tonneau cover. Check clearances at both rear corners between tonneau cover and vehicle tub. Gaps should be consistent. If tonneau cover is touching the vehicle tub or gaps are not even, adjustment of the tonneau position may be required. Refer to the **Tonneau Cover Position Adjustment** section of this fitting instruction for more information. **See Dia #23.**

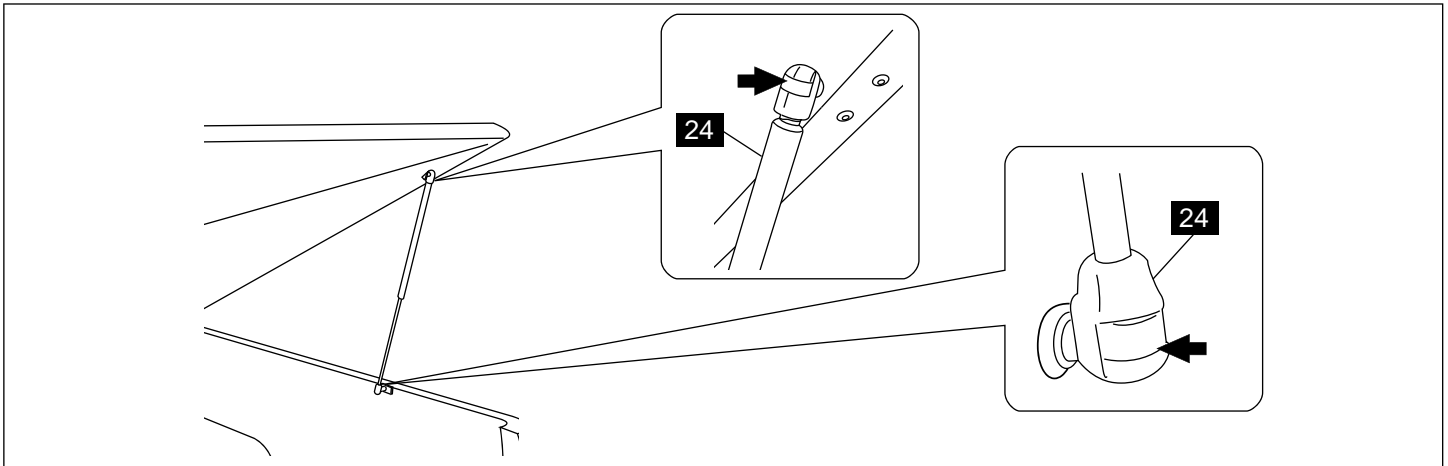

Diagram #24

24. Attach gas struts by clipping them into place. Ensure narrow end mounts to the vehicle. See Dia #24.

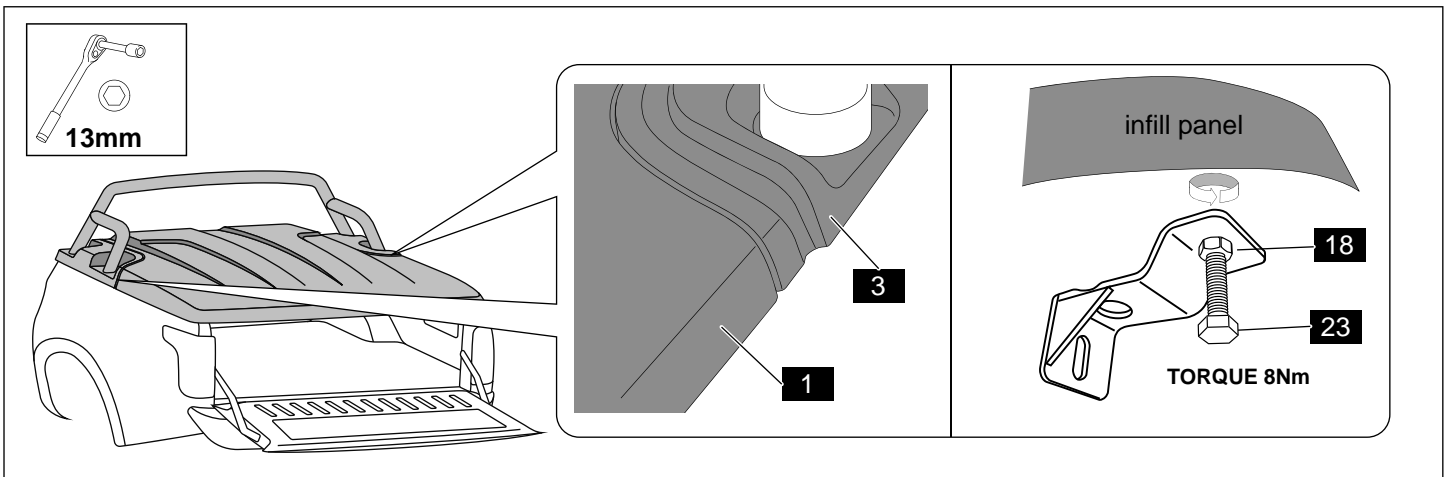

Diagram #25

25. Adjust jacking bolts until infill panels are level with the main surface of the Tonneau Cover. Once in the correct position, lock the M8 Nut into position against the bracket. Torque to 8Nm. See Dia #25.

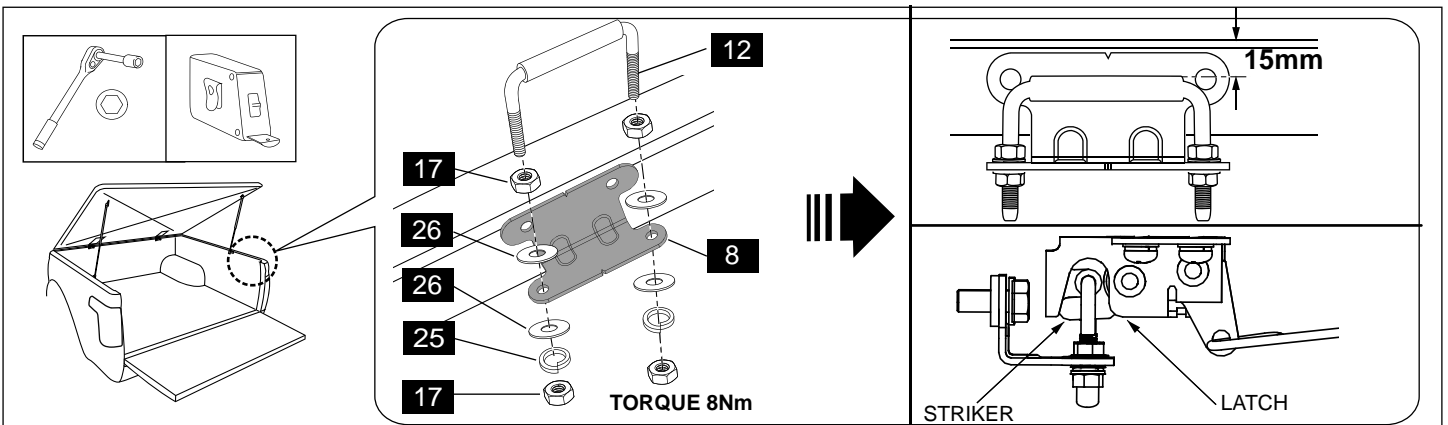

Diagram #26

26. Assemble striker U-bolt, M6 small flat washers, M6 stainless spring washers and M6 stainless hex nuts onto lock striker bracket. Set the striker height at 15mm to the top of tub rail. Carefully close the tonneau lid. Check the positioning of the striker hoops inside the locking pawl in the latches. The striker hoops should be centred in the latch pawl when the latches reach the second stage locking. If required slide the latches until they are correctly positioned. Ensure that the tonneau lid seals contact the vehicle tub. Tighten ensuring the distance to the top of the side rail is maintained, (Torque 8Nm). See Dia #26.

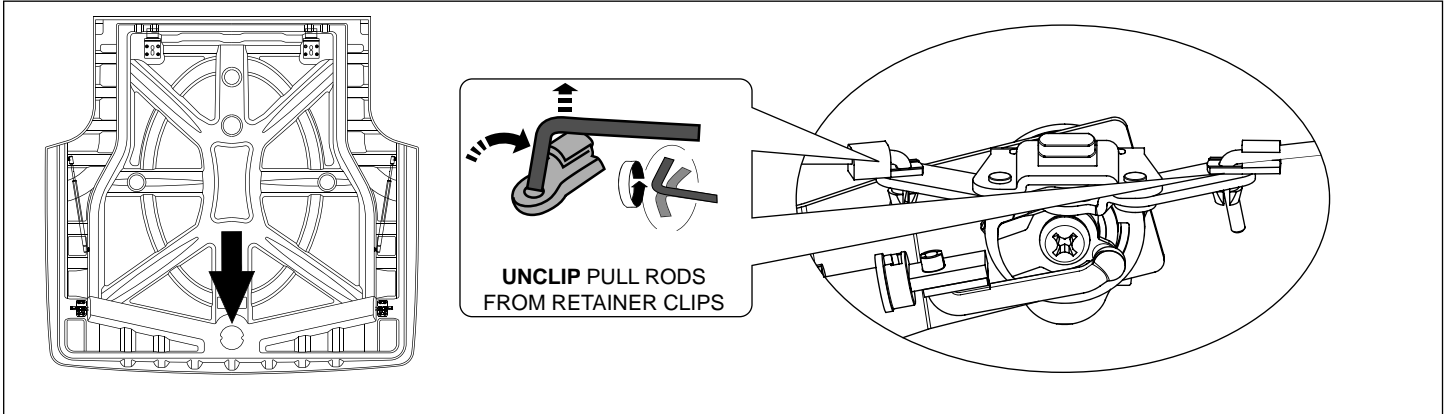

Diagram #27

27. If latches do not engage, carefully remove the scrivenets holding the lock access hatch cover in place and open the cover. Unclip the latch pull rods from the locking mechanism. Wind the pull rods in a clockwise direction to shorten and anti-clockwise to lengthen. After a few turns refit the pull rod and cycle test the locks. **See Dia #27.**

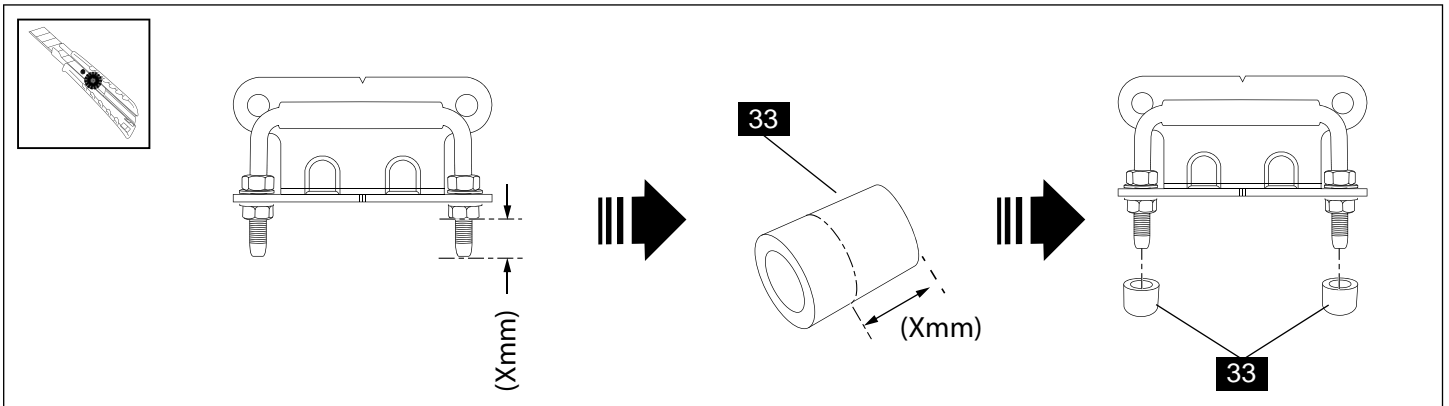
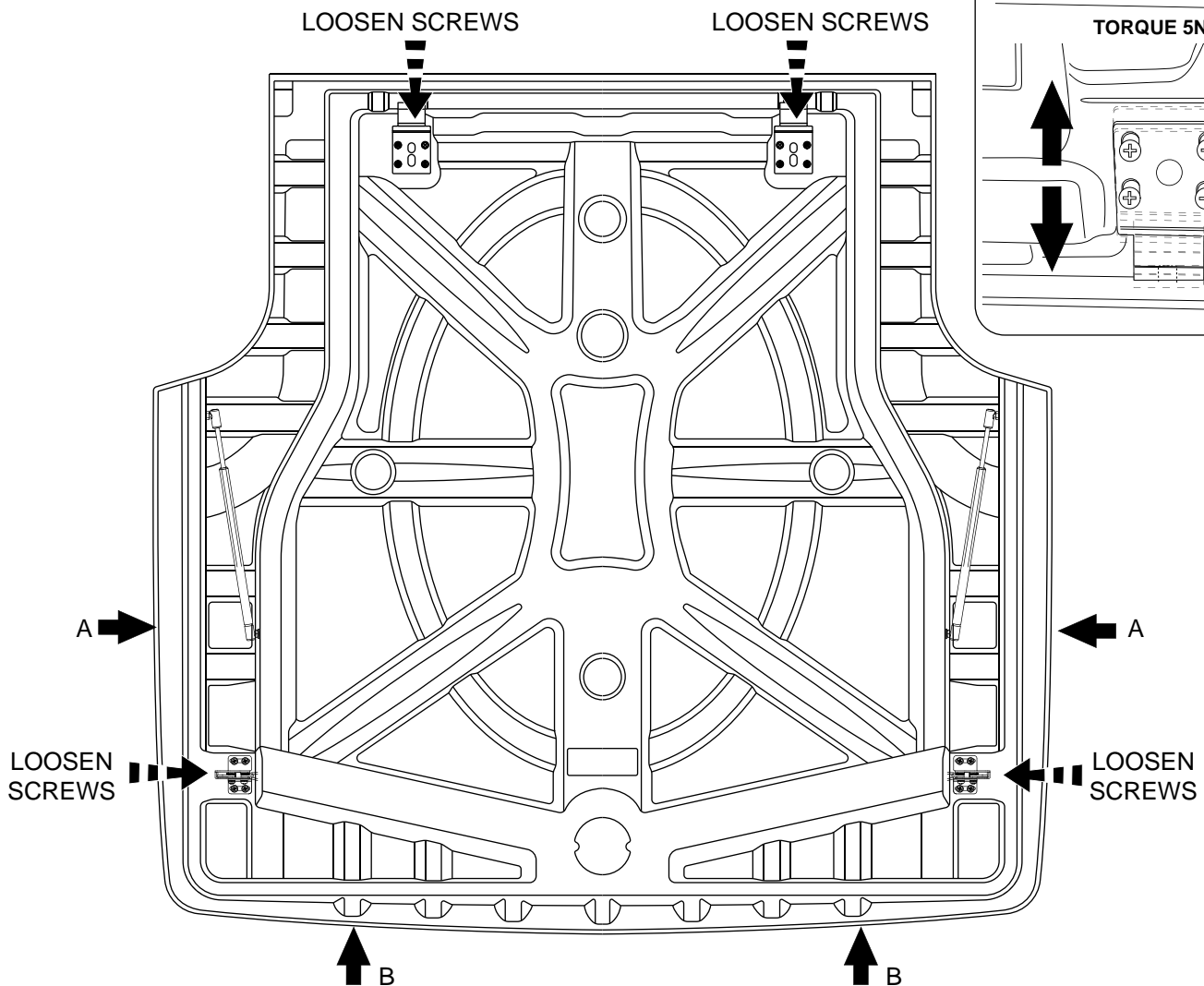

Diagram #28

28. Measure the length of exposed thread (Xmm) from bottom of the nut to the end of the thread. Measure length (Xmm) on the rubber thread cap and cut to length. Repeat for four thread caps and fit to threads. **See Dia #28.**

TONNEAU COVER POSITION ADJUSTMENT

1. Open the tonneau cover and lower the tailgate.
2. Loosen the screws on the hinges and latches at the positions shown.



3. Ensure that the gas struts are NOT attached. Adjust the position of the tonneau lid to the desired position or until the side and rear gaps are even, ie. $A=A$ and $B=B$. Tighten the hinge screws to 5Nm.
4. Perform a latch position adjustment and latch pull rod adjustment if necessary.
5. Tighten remaining screws to 5Nm.
6. Repeat steps 2-4 if further adjustment is required.

TONNEAU COVER REMOVAL AND RE-FIT

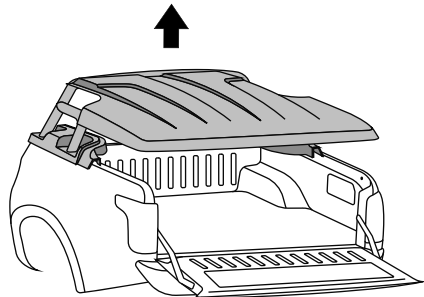

FIGURE 1

1. Open tonneau cover, Detach gas strut (1) by inserting a small screwdriver and adjusting the spring clip (2) on the gas strut (1). Refer to figure 2.
NOTE: Do not remove the spring clip. only a small amount of levering is required to detach.

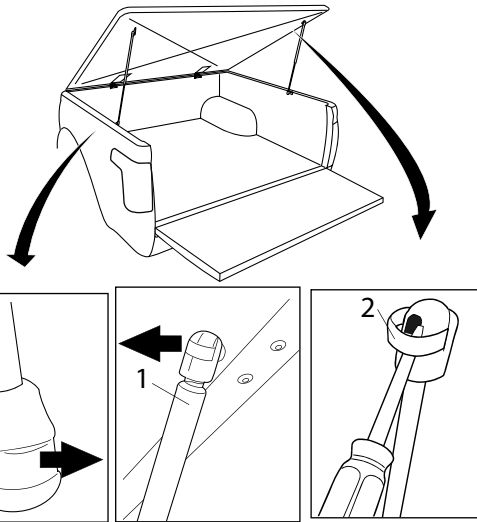

FIGURE 2

NOTE: 2 people are required to lift and remove the tonneau cover from the vehicle.

2. Remove hinge pins (1) and remove tonneau cover (2). Refer to figure 3.

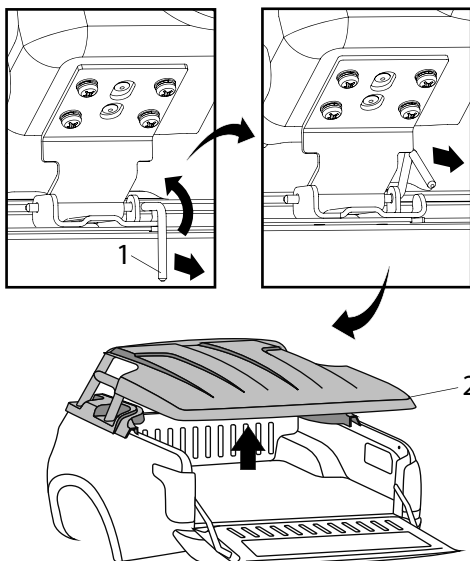

FIGURE 3

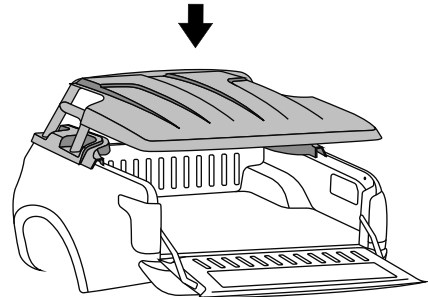

FIGURE 4

NOTE: 2 people are required to lift and fit the tonneau cover onto the vehicle.

1. Fit tonneau cover (2) and secure hinges with hinge pins (1). Refer to figure 5.

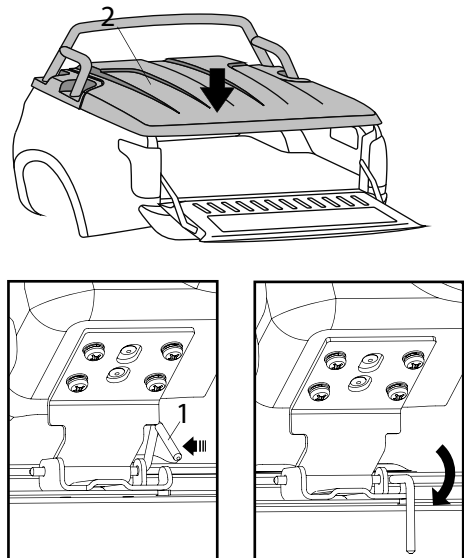

FIGURE 5

2. Attach gas struts (2) by clipping into place. Ensure narrow end (1) mounts to the vehicle. Refer to figure 6.

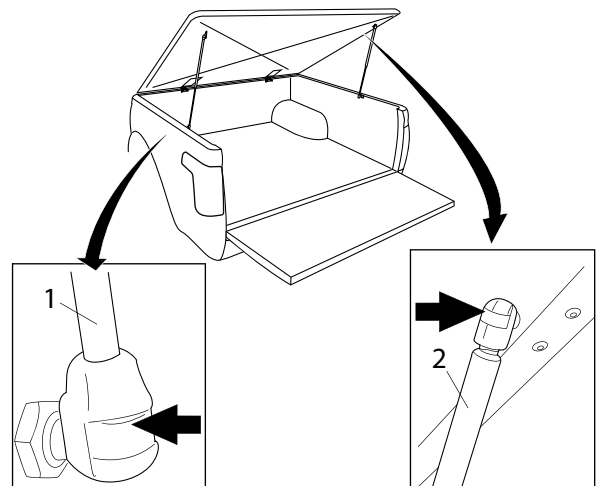

FIGURE 6