

**INSTALLATION INSTRUCTION  
3 PIECE HARD TONNEAU COVER**

Printed Copies are uncontrolled  
Expert Fitment Required  
Subject to alteration without notice

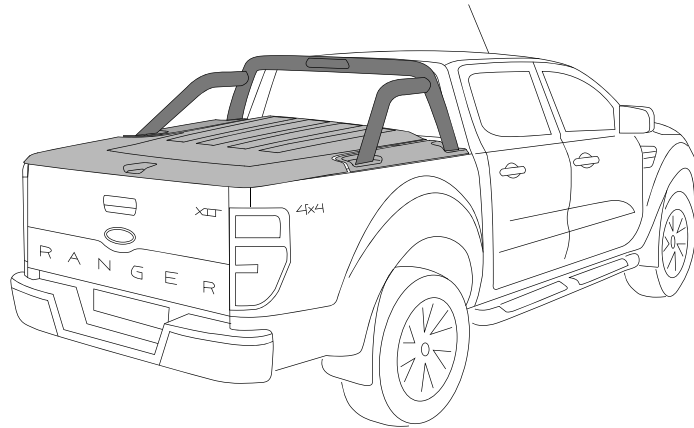

**Care Instructions:**



Clean Tonneau Cover with a mild detergent and water solution.



Do not use abrasive cleaners or solvents.

**Place these instructions in vehicle's glove box after installation is complete**

**WARNING!**

When in the closed position, Tonneau Cover must be latched and tailgate must be closed! Failure to do so could result in unexpected opening of the Tonneau Cover from sudden wind gusts, driving conditions, which could cause damage to the vehicle and/or your Tonneau Cover!

DO NOT close the Tailgate when the Hard Tonneau is in the closed position, as damage may occur to the vehicle and/or your Tonneau Cover!

**MAINTENANCE:**

Only use cleaners, waxes, or products that are labelled safe for use on plastics. Avoid the use of any chemicals to clean your Tonneau Cover unless labelled safe for plastics. Avoid use of abrasive type cleansers as they may dull the finish.

The gas struts are self lubricating and should only be cleaned occasionally with a damp cloth. Premature seal failure will result if solvents or lubricants are used to clean struts.

Gas struts must be connected with the cylinder (wide) end to the Tonneau Cover or Warranty is Void.

The locking mechanisms and latches only require occasional lubrication with Graphite Powder.

DO NOT use any other lubricants or oils. Using alternative products will VOID Warranty.

All installation hardware and fasteners must be checked every so often for tightness.

**TONNEAU COVER - IMPORTANT:**

- Read instructions carefully before installation. It is strongly recommended that installation is conducted by an authorized dealer.
- This product must be installed exactly as specified in these instructions. Failure to do so may result in improper fit and/or retention.
- Do not stand/sit or rest heavy objects on Tonneau Cover.
- Humans or animals are not to be under the closed Tonneau Cover at any time.
- Securely latch Tonneau Cover before operating vehicle.
- Do not carry open volatile chemicals with Tonneau Cover installed.
- If contact with volatile chemicals occurs clean Tonneau Cover with mild detergent and water solution.
- Recommend installation by 2 people.
- Fitting Instructions must be given to the end customer to understand correct removal and replacement process onto the vehicle.

**PAINTING INSTRUCTIONS: (IF UNPAINTED)**

- Prior to painting, clean all surfaces to be painted using clean water and a mild detergent, do not use lacquer thinner or any solvent based products. Wipe completely dry.
- Best results will be achieved by wiping the areas to be painted with a tack rag just prior to painting.
- Select a top coat and clear paint that is suitable for PC/ABS (Poly-Carbonate-Acrylonitrile-Butadiene-Styrene).
- Automotive paint systems, such as Acrylics or Two Packs, can be applied directly to the components. However, some paints may require a primer. If recommendations on paint specification are not followed, cracking of the part or degradation to the material may result. In all paint systems, aromatic hydrocarbons and alkalis are best avoided to reduce damage to the material properties.
- If using a paint system which requires baking, do not expose the product to temperatures above 70° C (155° F).
- Allow a minimum of 8 hours after baking before installation on the vehicle.

**FORD RANGER 2012** ➔

**FORD RANGER 3 PIECE HARD TONNEAU COVER**

**PARTS CHECK SHEET**

**PARTS IN MAIN CARTON**

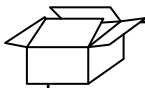

**1**

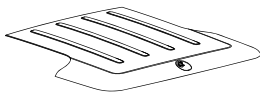

Tonneau Cover  
Qty - 1

**2**

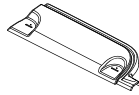

LHS Corner  
Piece  
Qty - 1

**3**

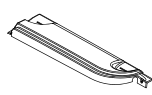

RHS Corner  
Piece  
Qty - 1

**4**



Lock Keys  
Qty - 2

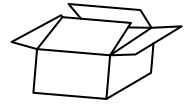

Fitting Kit  
(KIT032373)  
Qty - 1

**PARTS IN FITTING KIT (KIT032373)**

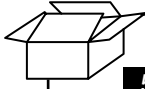

**5**

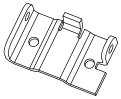

Hinge Lower  
(CLIP2720PC)  
Qty - 2

**6**

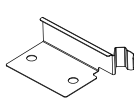

Hinge Pin  
Retainer  
(CLIP2717-1)  
Qty - 2

**7**



Hinge Pin  
(CLIP2032)  
Qty - 2

**8**



Gas Strut  
Standard  
(STRT0005-2)  
Qty - 2

**9**



Jacking  
Bracket  
(CLIP2049-1)  
Qty - 2

**10**

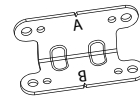

Lock Striker  
Bracket  
(CLIP2499-PC)  
Qty - 2

**11**



Striker U-Bolt  
(LOCK0006)  
Qty - 2

**12**



M8 Hex  
Nut  
(NUTS0217)  
Qty - 2

**13**



M8x40 C/Sunk  
Head Screw  
(SCRW0847)  
Qty - 8

**14**



Rivet  
(FAST0505)  
Qty - 21

**15**



M6x20 Hex  
Head Bolt  
(SCRW0028)  
Qty - 14

**16**



M6 Flat  
Washer Small  
(WASH0153)  
Qty - 30

**17**



M6 Nyloc  
Nut  
(NUTS0016)  
Qty - 8

**18**

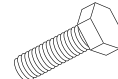

M8x50 Hex  
Head Bolt  
(SCRW0789)  
Qty - 2

**19**



Ball Strut  
Bracket  
(CLIP2034-1)  
Qty - 2

**20**



M6 Hex  
Nut  
(NUTS0161)  
Qty - 8

**21**

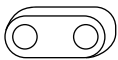

Spacer short  
10mm thick  
(MISC3405)  
Qty - 2

**22**

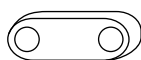

Spacer long  
8mm thick  
(MISC3404)  
Qty - 2

**23**



Scrivet  
(FAST0086)  
Qty - 2

**24**



Upper Tailgate  
Bracket  
(CLIP2834PC)  
Qty - 2

**25**

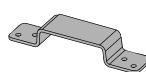

Tailgate  
Top Hat  
(CLIP2875PC)  
Qty - 2

**26**



Alcohol  
Wipe  
(MISC0052)  
Qty - 4

**27**

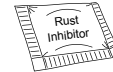

Rust  
Inhibitor  
(MISC2776)  
Qty - 2

**28**

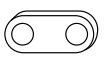

Spacer s/s  
3mm thick  
(CLIP2969)  
Qty - 6

**29**



Support Bracket  
for Striker Bracket  
(CLIP2849PC)  
Qty - 2

**30**



M6 Spring  
Washer  
(WASH0103)  
Qty - 4

**31**



M8 Flat  
Washer Small  
(WASH0171)  
Qty - 4

**32**



M8 Nyloc  
Nut  
(NUTS0242)  
Qty - 2

**33**



M8x20 Hex  
Head Bolt  
(SCRW0665)  
Qty - 2

**34**

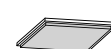

S/S Contact Plate  
(CLIP2308-1)  
Qty - 2

**35**



Fitting  
Instruction  
(FIT-TC0396)  
Qty - 1

**PARTS IN KIT (KIT032369)**

**36**

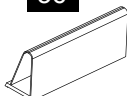

Header  
Rail Seal  
(MISC2229-9)  
Qty - 1

**37**

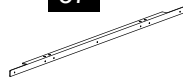

Header  
Rail  
(HBAR0013-1)  
Qty - 1

**38**

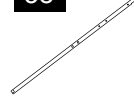

Side Drill  
Template  
(MISC3452)  
Qty - 1

**TOOLS REQUIRED:**

- Fine Point Non Permanent Marker
- Centre Punch
- Drill
- Ø3, Ø5.5, Ø7 & Ø9mm Drill Bits
- Torque Wrench
- Rivet Gun
- Scissors or Sharp Knife
- Spanners 10mm 13mm
- Socket Set
- Non-acetic Silicone
- Paint Pen
- Phillips and Flat Screwdrivers
- Allen Key
- Tape Measure
- Masking Tape
- Torx Head Set



# IMPORTANT - BEFORE INSTALLING TONNEAU COVER

Remove and discard the Cabin Guard  
Remove & retain the Sports Bar and all Hardware.

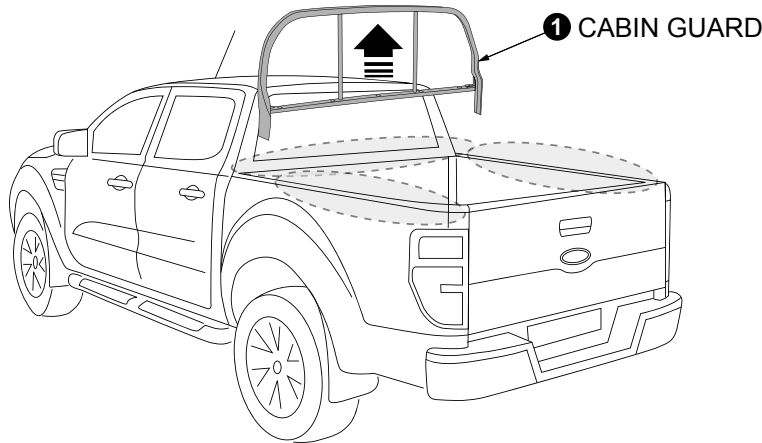

2

CLEAN & DRY  
INSTALLATION AREAS

Diagram #:1

1. **NOTE: Two people are required to complete the installation.** Remove cabin guard if fitted. Thoroughly clean and dry the installations areas. See Dia #1.

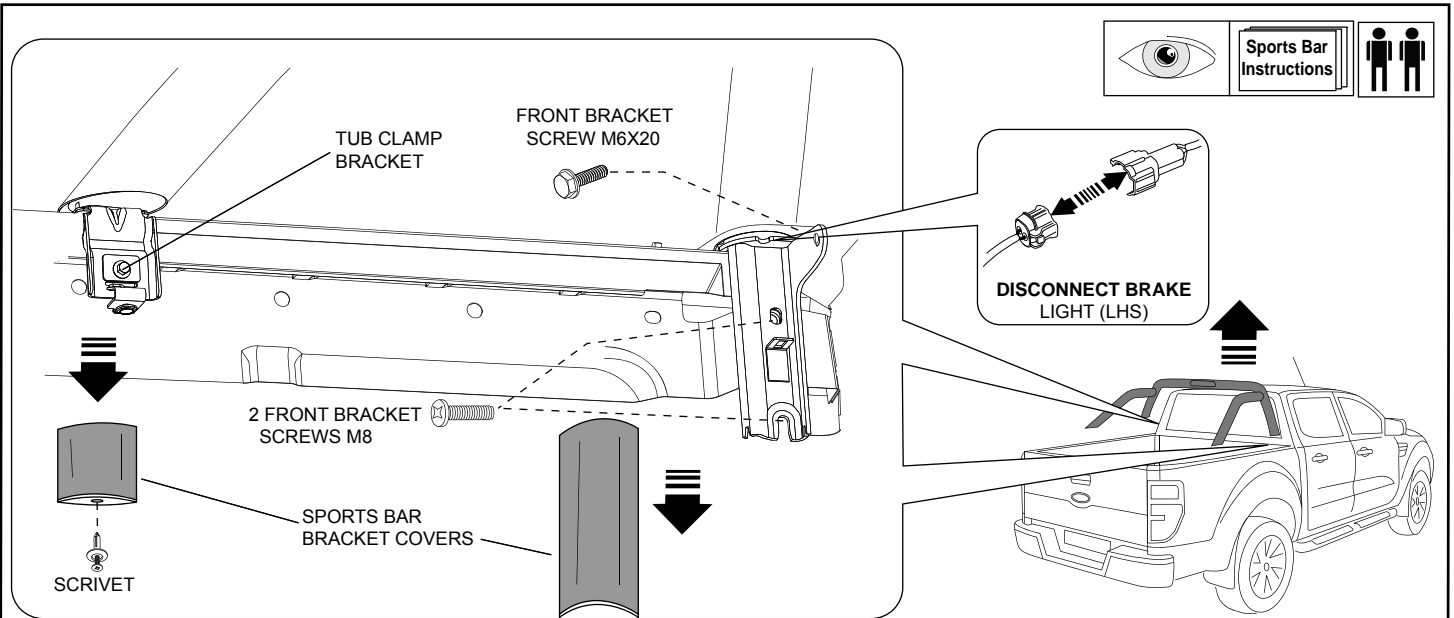

Diagram #:2

2. **NOTE: Two people are required to complete the installation.** Remove and retain the sports bar and all hardware. Thoroughly clean and dry the installations areas. See Dia #2.



Diagram #:3

3. Place masking tape in sections along the entire length of the side rails as shown. See Dia #3.

**IF VEHICLE IS FITTED WITH A BEDLINER GO TO STEP 4, OTHERWISE PROCEED TO STEP 5**

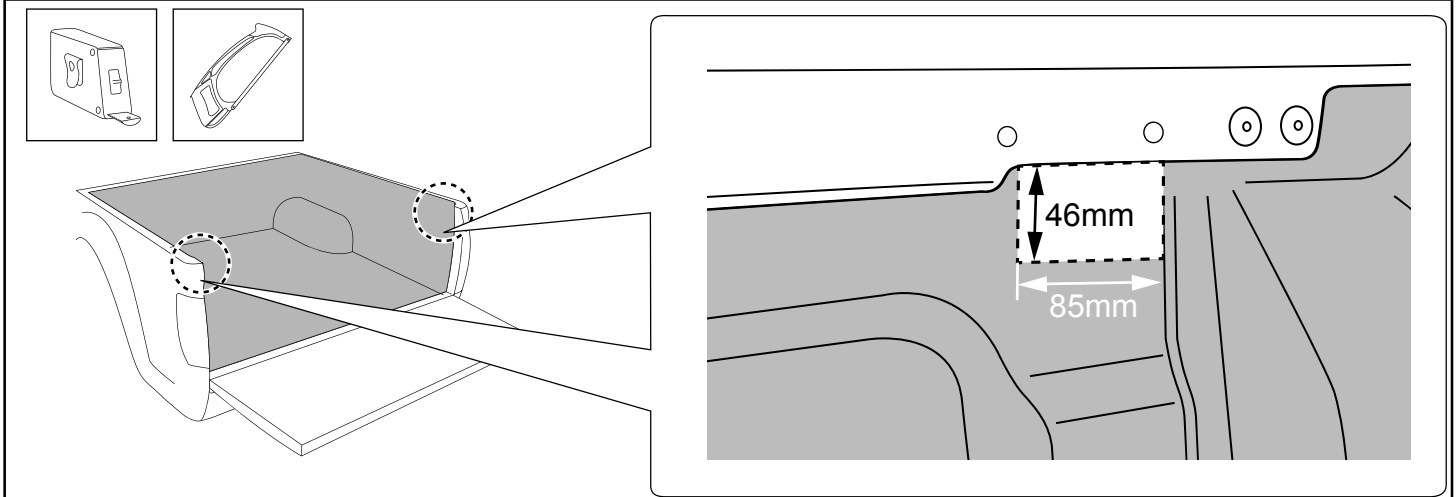

**Diagram #4**

4. Trim the bedliner to clear the Striker Support Bracket as per the dimensions shown for the RHS. Repeat for LHS. If necessary, remove the tub liner to make trimming easier. **See Dia #4.**

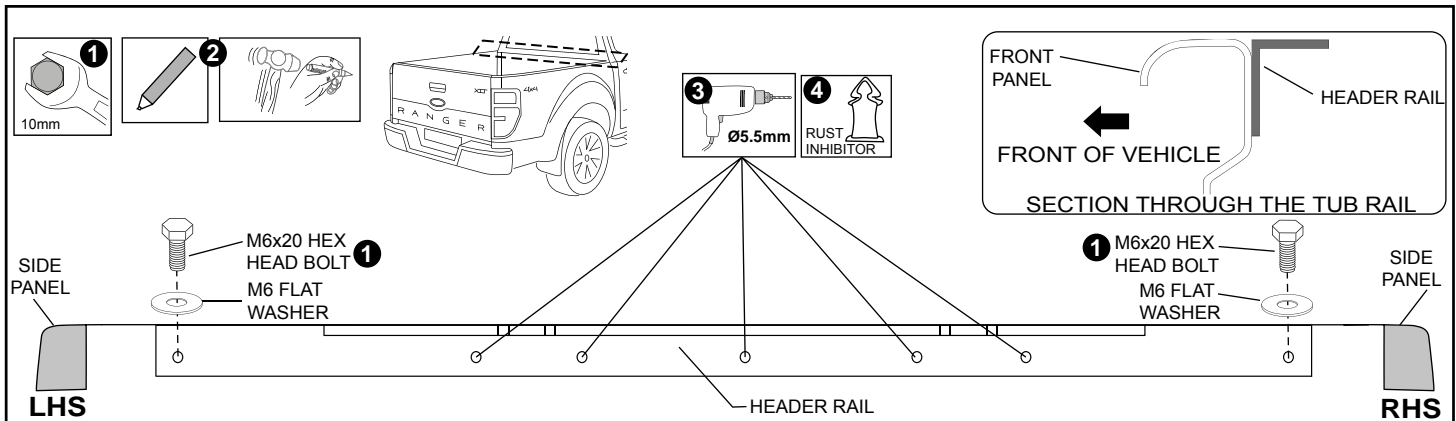

**Diagram #5**

5. Attach header rail to the front of the tub using two M6x20 screws and washers. Note the header rail orientation as shown in the section view. Mark and center punch the five hole locations in header rail. Remove the header rail. Drill five (5) holes through the tub using 5.5mm drill. Remove all burrs, sharp edges and swarf from vehicle. Apply rust inhibitor to all drilled holes. Reattach the header rail with screws and washers. **NOTE: Top of header rail is to be flush with top of front bed rail. See Dia #5.**

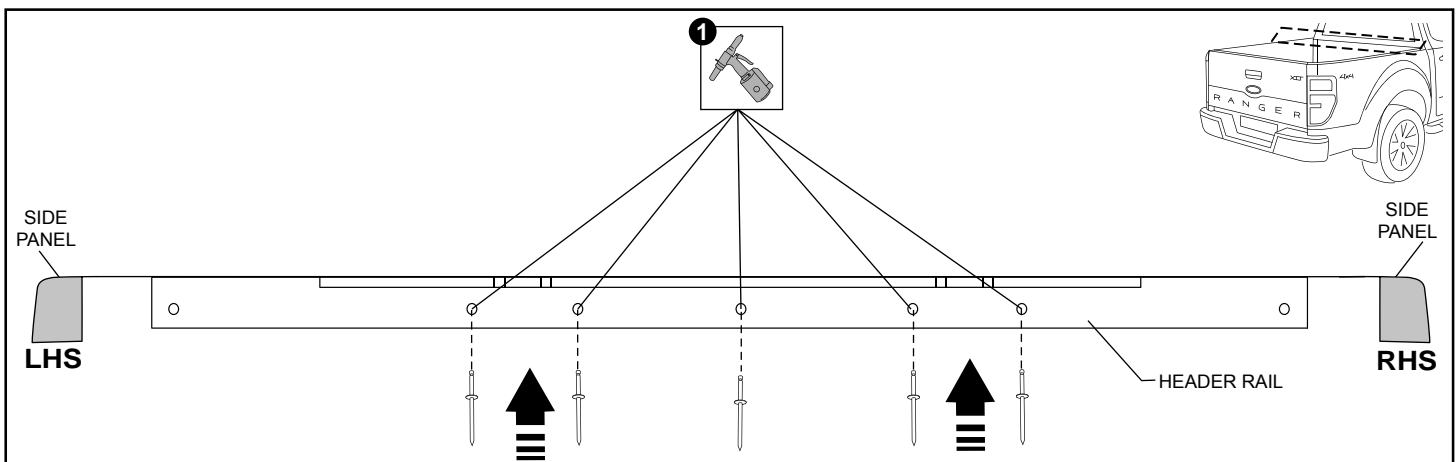

**Diagram #6**

6. Rivet the header rail to the tub using five (5) rivets. Once rivets are in, remove M6 screws and retain for step 16 to install sports bar. **NOTE: Header rail to be flush with top of front bed rail. See Dia #6.**

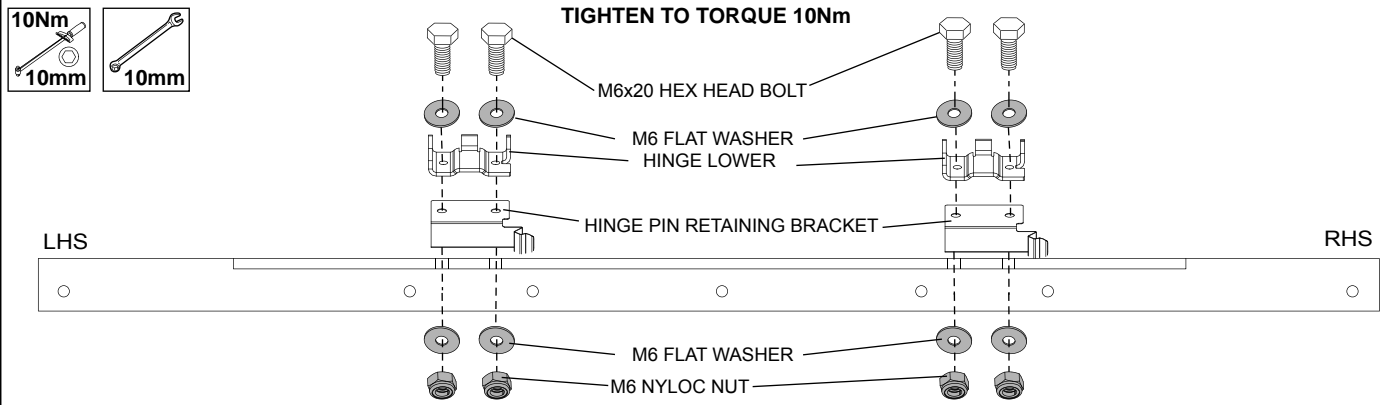

Diagram #:7

7. Orient the two (2) lower hinges as shown. Align the holes in the hinge lower with the slots in the header rail. Secure with two (2) M6x20 hex head bolts, four (4) M6 flat washers small and two (2) M6 nyloc nuts for each hinge as shown. **Do not overtighten at this point. Allow side to side movement for adjustment once the tonneau cover is installed. See Dia #7.**

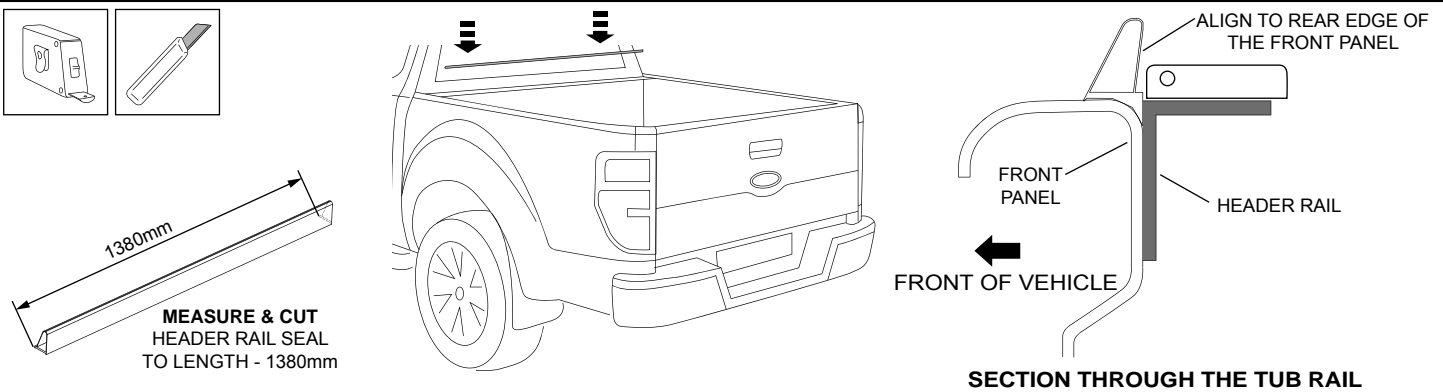

Diagram #:8

8. Measure and cut header rail seal to a length of 1380mm. Locate the centre of the header rail seal and trial fit to the front panel, ensure seal is oriented correctly and centred to the tub. Remove approximately 50mm length from one end of liner. Orient and align centre of seal with centre of front panel and rearward edge of seal against the lower hinge as shown. Starting from one end apply firm pressure and remove liner along the length of the seal, ensuring seal runs parallel with the edge front panel. **See Dia #8.**

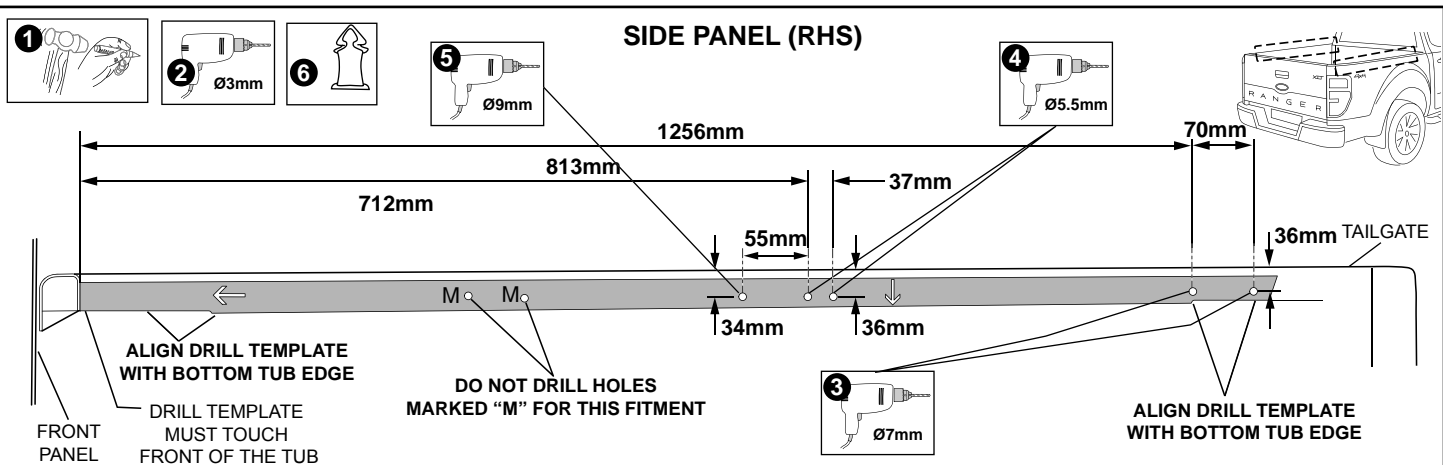
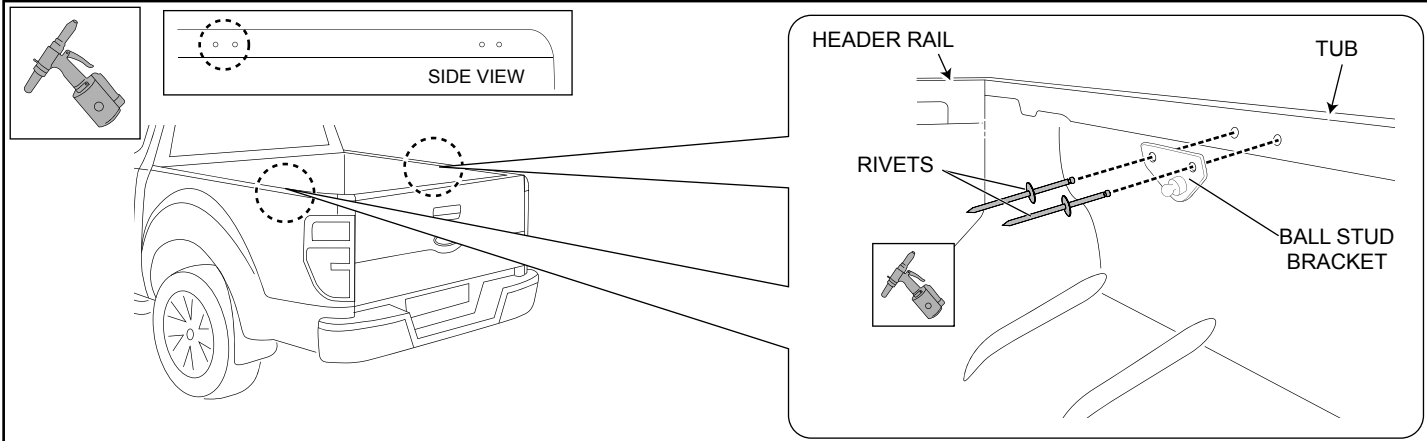

Diagram #:9

9. Position the side drill template against to the side of the tub bed rail as shown, ensuring arrows are facing down and to the front of the vehicle. The drill template shape matches the bottom shape of the side of the bed rail. Align the bottom of the template with the bottom of the bed rail as shown. Attach using masking tape. Mark and centrepunch the two unmarked holes in the middle and the two rear most positions. **Do not use the holes marked with an "M".** Drill all holes with Ø3 pilot drill and remove the drill template. Drill two (2) holes Ø7mm, two (2) Ø5.5mm and one (1) Ø9mm as shown. Repeat process by reversing the template to use on the other side of the vehicle. Remove all masking tape from the side rails. Remove all burrs, sharp edges and swarf from vehicle. Apply rust inhibitor to all drilled holes. **See Dia #9.**



**Diagram #:10**

10. Fit the ball stud bracket to the side rail and secure with two (2) rivets. Repeat process for the other side of the vehicle. **See Dia #10.**

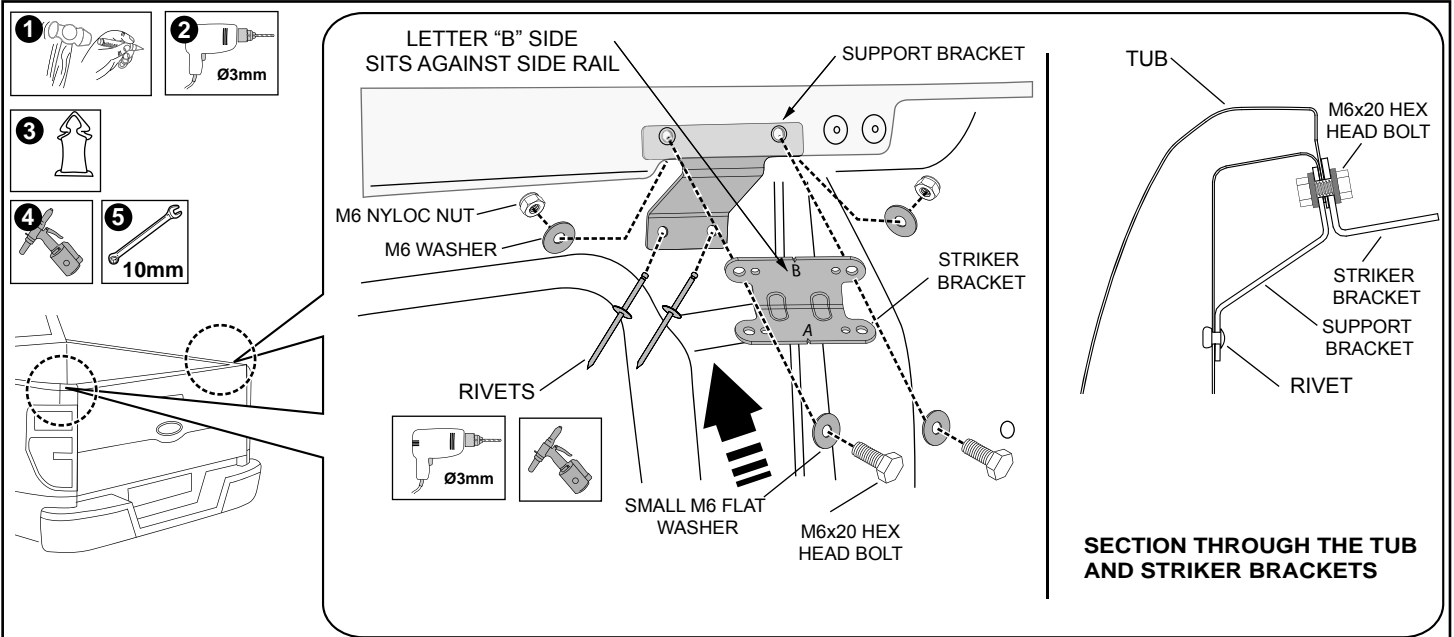

**Diagram #:11**

11. Attach the striker bracket and support bracket to the tub using M6 screws, M6 washers, M6 nylock nuts and rivets. Note the orientation of the striker bracket. Position face "B" of lock striker bracket against the side rail as shown. Centerpunch and drill  $\varnothing 5.5\text{mm}$  the two lower holes in the support bracket and secure with two rivets. Tighten all bolts to 9Nm. **See Dia #11.**

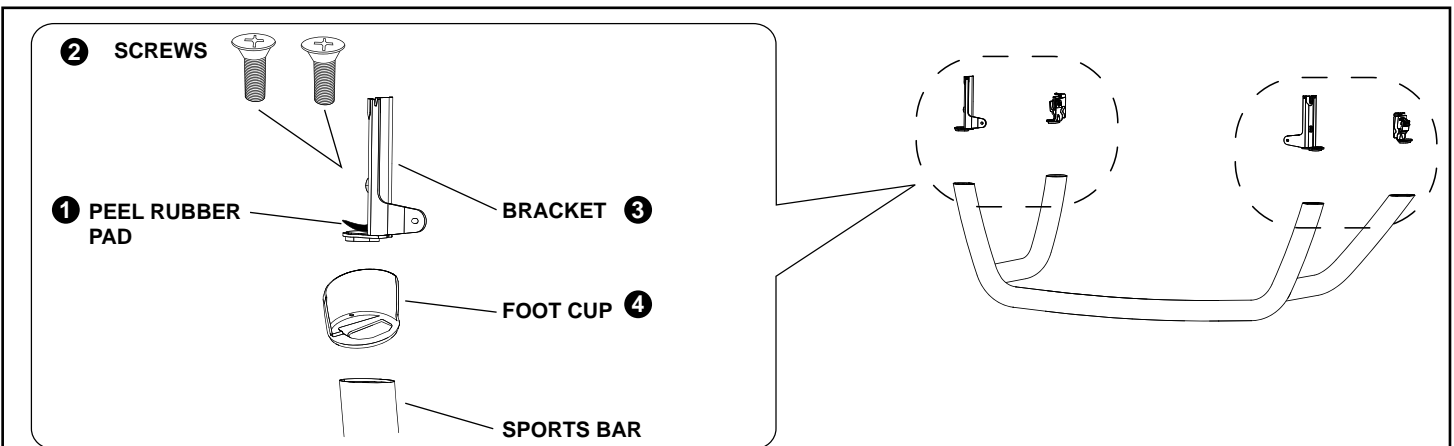

**Diagram #:12**

12. Peel rubber pad from the bracket from the sports bar, to gain the access to the screws (keep the rubber pad to refit in step 14). Remove attachment brackets from all of the sports bar legs (4) and discard the screws (8). **See Dia #12.**

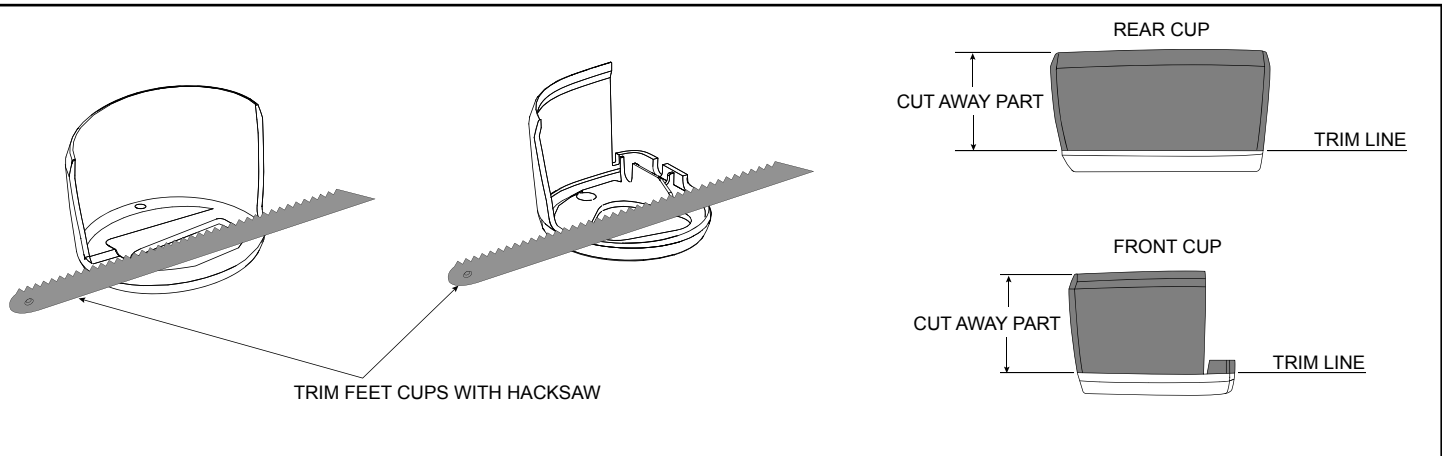

Diagram #:13

13. Trim the feet cups extension as shown using a hacksaw or sharp knife. Smooth rough surface with sandpaper. See Dia #13.

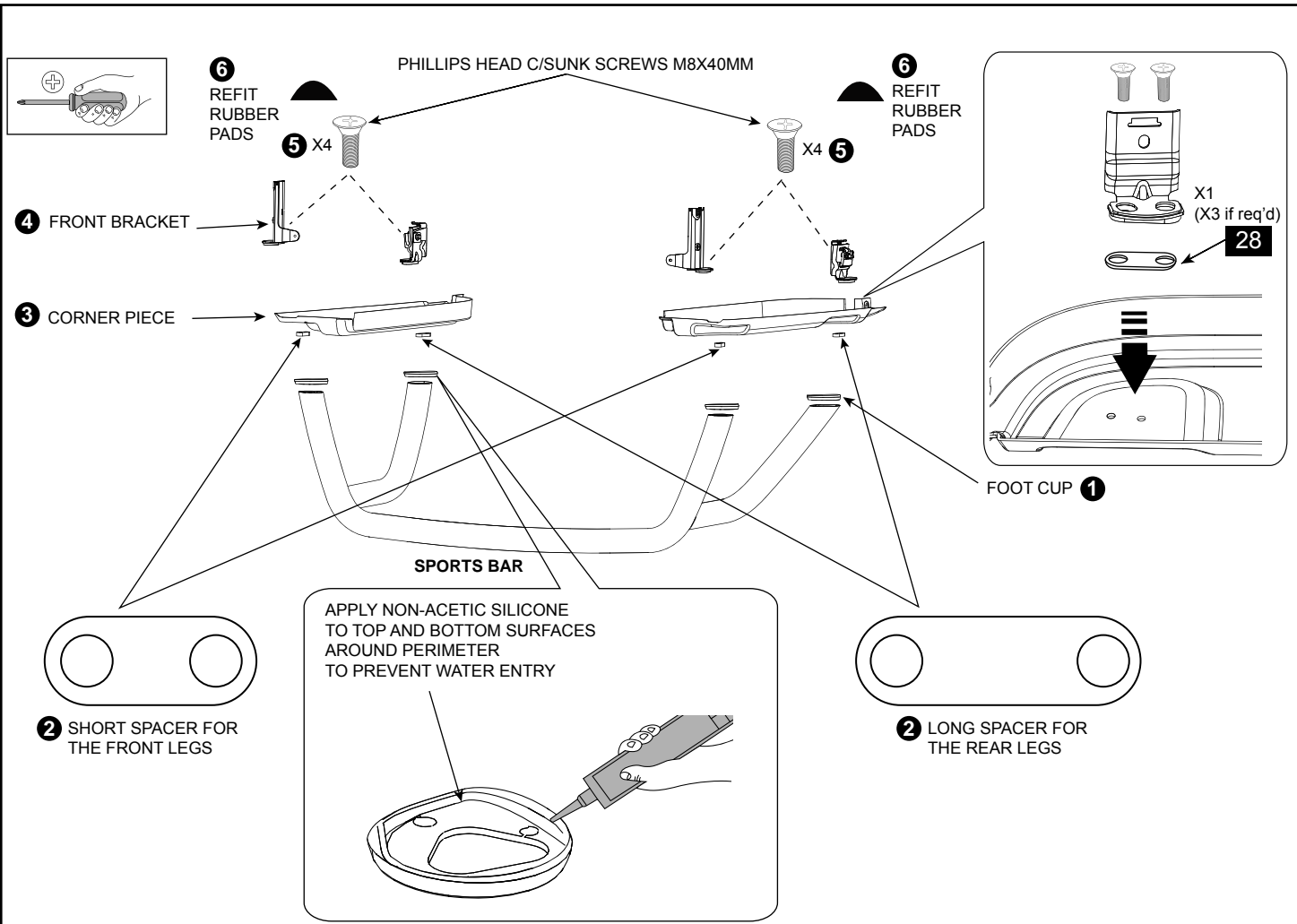

Diagram #:14

14. Apply a non-acetic silicone perimeter bead to both sides of the cut down foot cups and refit into the sports bar legs. Place one (1) spacer plate on top followed by the tonneau corner pieces. Starting with front bracket screw the two M8x40mm bolts into the sports bar. Test fit the corner pieces and tonneau lid onto the vehicle. If there is no contact on the seal between the corner pieces and lid add additional spacers as necessary. Attach the rear bracket back to the corner piece with three 3mm packers inserted between the corner piece and the bracket as indicated above. Repeat same procedure for the opposite side of the sports bar. Note: Remove any excess silicone. See Dia #14.



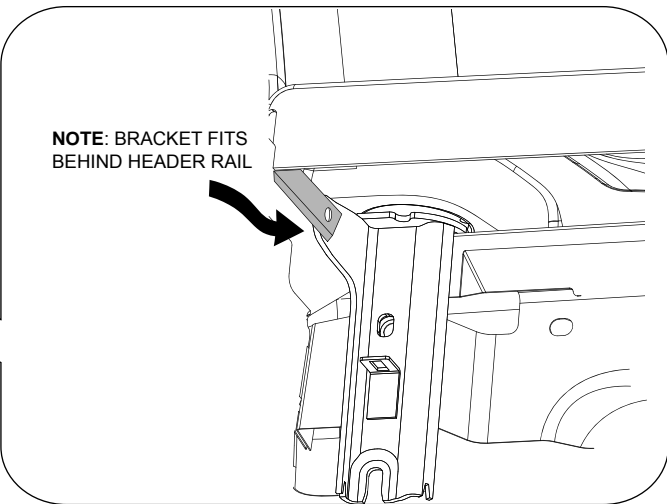
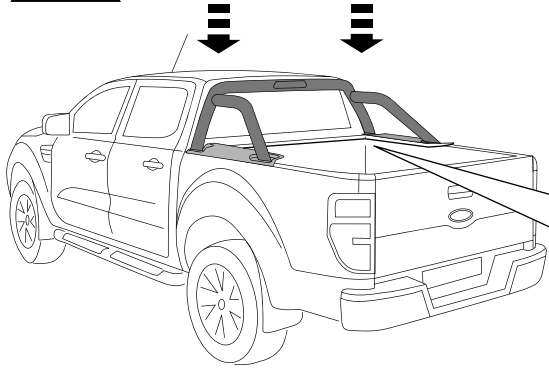
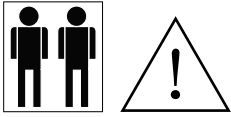
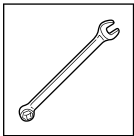

Diagram #:15

15. Carefully position the assembled sportsbar and corner pieces onto the tub, taking care not to scratch the vehicle. Ensure the front sports bar bracket is positioned between the front panel and header rail already fitted.  
**NOTE: Two people are required to lift into position. See Dia #15.**



FIT PLATE INSIDE THE CORNER PIECE

34

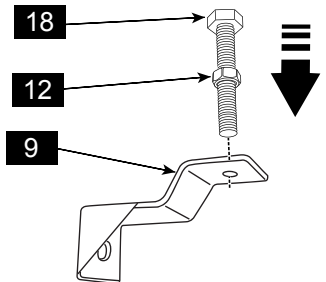
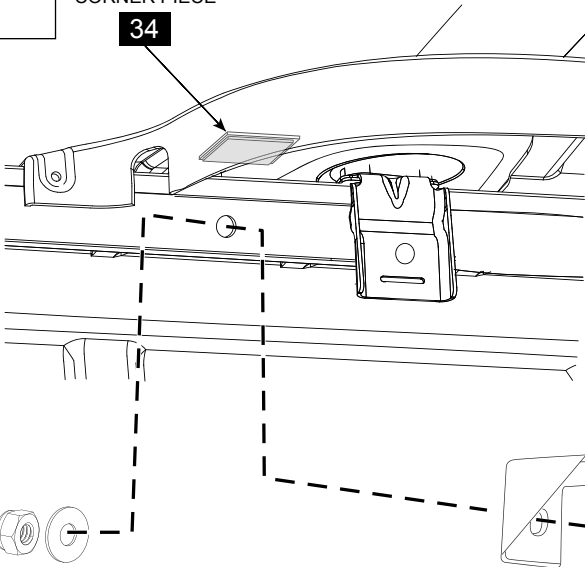

INSERT M8 SCREW AND NUT.  
 TURN SCREW ALL THE WAY DOWN

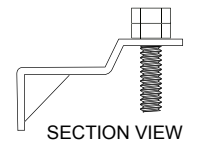

Diagram #:16

16. Assemble the jacking brackets as shown. Fit and align the jacking bracket to the previously drilled 9mm hole. Attach using M8 bolt, M8 flat washer and M8 nylock nut as shown. Align the jacking bracket vertically in the middle of the slot and tighten to 8Nm. Repeat for other side (LHS shown). Note where the bolt head on the jacking bracket will contact the underside of the corner piece. Prime this spot with a primer stick and adhere one of the stainless steel contact plates in place. Repeat for other side. **See Dia #16.**



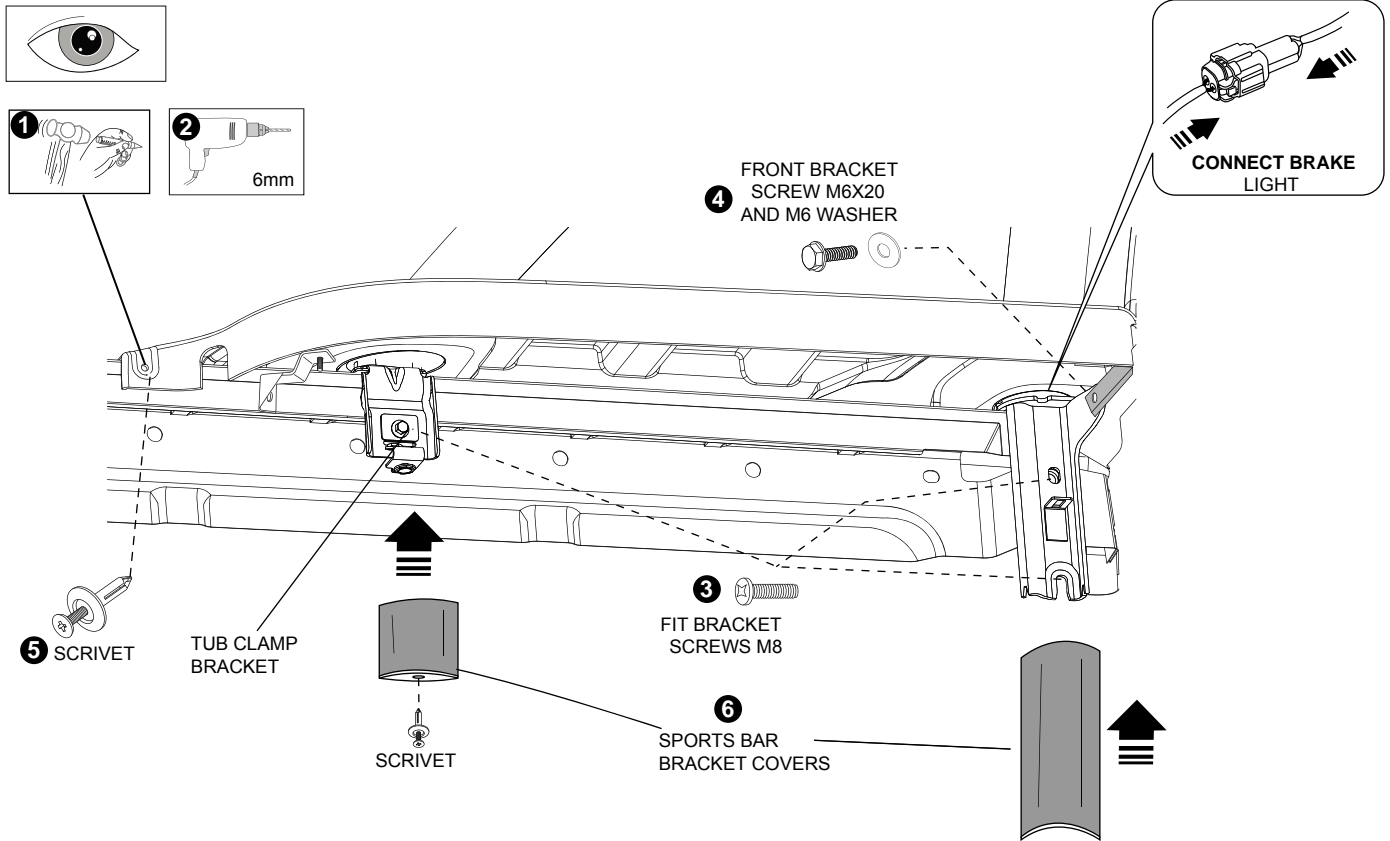

Diagram #:17

17. Two people are required for this step, one to apply firm pressure and the other to mark the positions. Apply pressure to push the corner piece and front sports bar feet firmly into the front corner of the tub and down onto the side rail. Mark and centre-punch the scrivet hole position. Repeat process for the other side of the vehicle. Carefully remove sports bar and corner piece assembly. Drill the marked hole with 6mm drill and apply rust inhibitor. Place the sports bar back onto the tub and secure the sports bar to the tub with the sports bar hardware. Reconnect the stop light wiring and refit the sports bar support bracket covers. Push the scrivets (2) into position. **See Dia #17.**

**IMPORTANT:** Ensure vehicles's tailgate is opened before installing Tonneau Cover, and remains open until lock striker is fitted and locking mechanism is adjusted correctly. **DO NOT** close the Tailgate when the Hard Tonneau is in the closed position, as damage may occur to the vehicle and/or your Tonneau Cover!

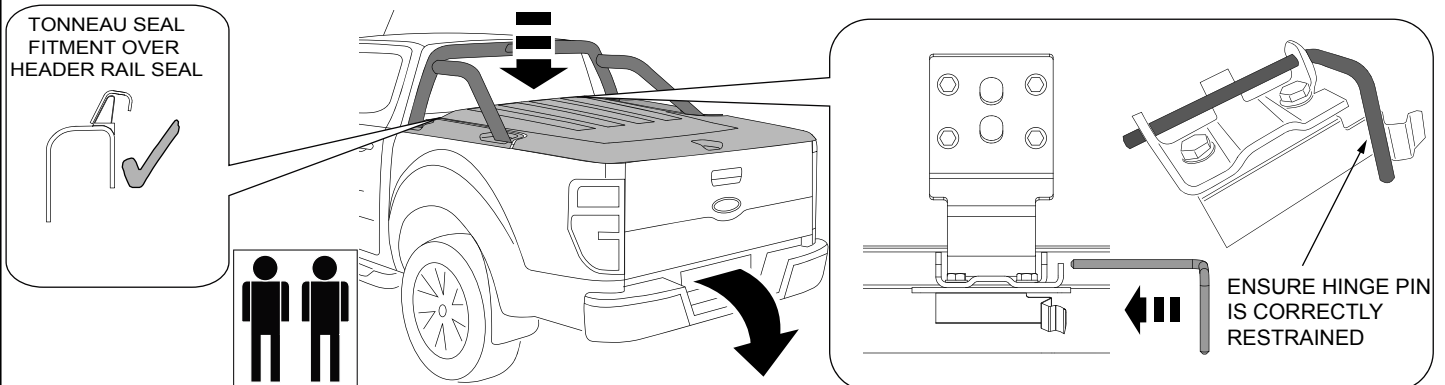
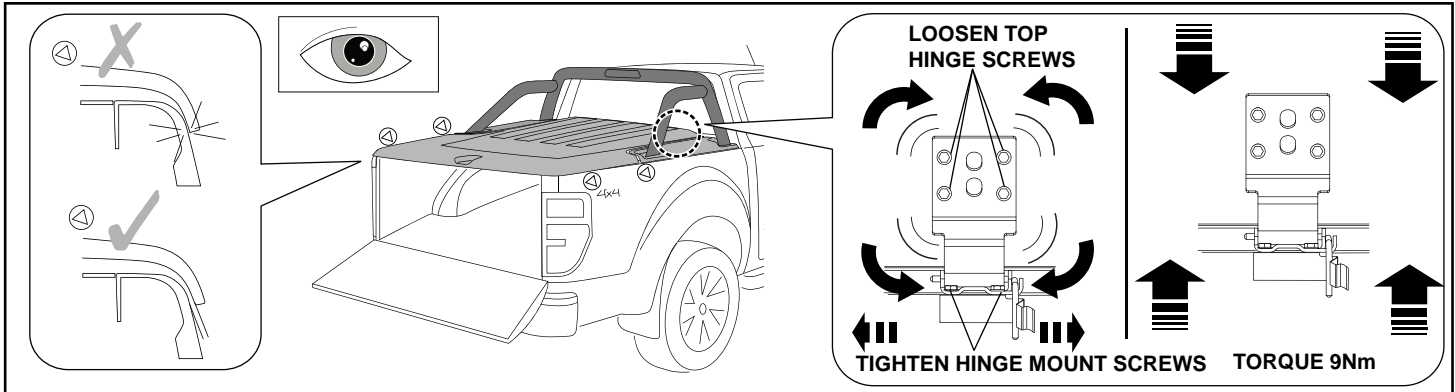

Diagram #:18

18. **Open vehicle's tailgate and keep it open until locking mechanism has been adjusted correctly.** Two people are required to carry out the fitment of the tonneau cover. Carefully fit tonneau cover to vehicle ensuring seal at the front of the tonneau cover sits correctly over the header rail seal as shown, If incorrectly placed this can direct water into the tub. Secure hinges with hinge pins as shown. **See Dia #18.**

**IMPORTANT:** Ensure hinge pins clip into retaining leg on lower hinges, ensuring pin is securely restrained. If misaligned, seal can be pushed forward from inside of the tub.



19. With tailgate open, Close and check Tonneau Cover is central to vehicle and the sides of Tonneau Cover do not contact the vehicle bedrail. Adjust position by loosening the top hinge screws for fore and aft adjustment and hinge mount screws for side to side adjustment to re-position Tonneau Cover to fit centrally on vehicle. Before screwing tight, align each lower hinge section outwards in order to prevent side play. Tighten all hinge brackets to **Torque 9Nm**. See Dia #19.

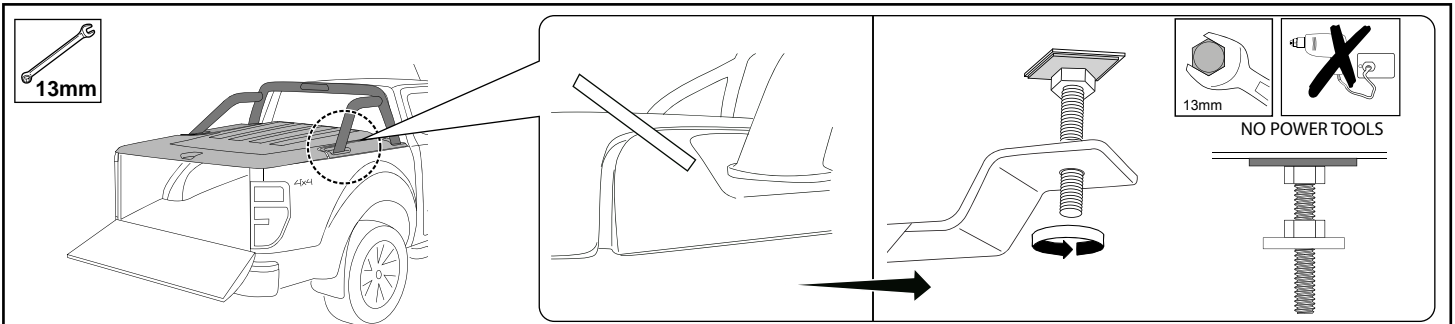

20. Adjust jacking bracket bolt to level corner piece to the main surface of the Tonneau. Once in the correct position, lock the bolt into position against the bracket by tightening the M8 nut. Repeat process for the other side of the vehicle. See Dia #20.

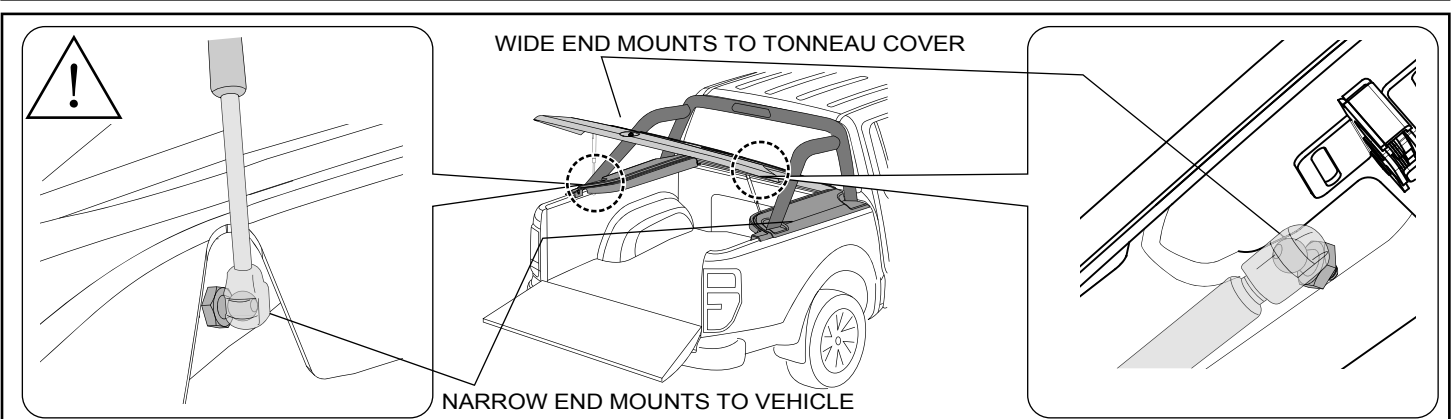

21. Attach gas struts by clipping into place as shown. **Ensure the narrow end mounts to the vehicle and the wide end mounts to the tonneau cover. See Dia #21. !! Failure to do so Voids Warranty on gas struts!!**

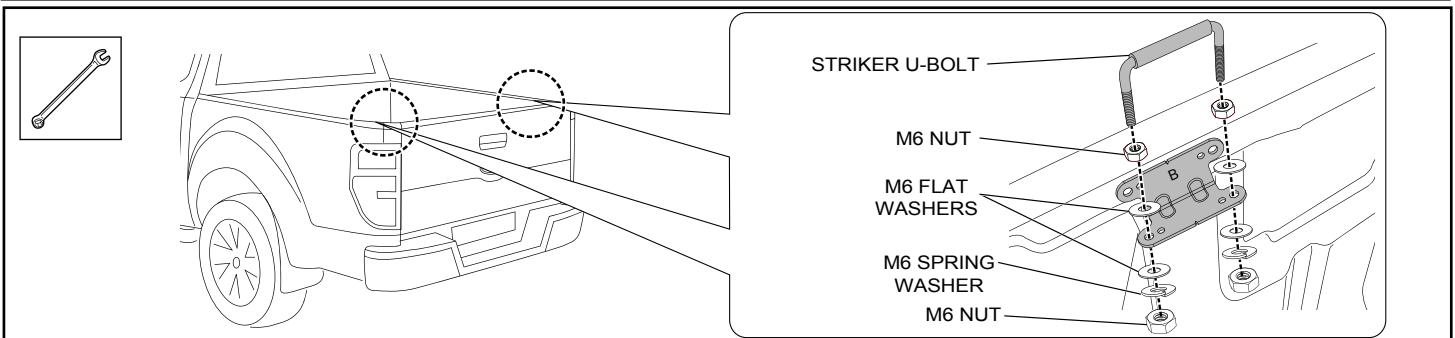

22. Fit the striker U-bolt to the striker bracket using nuts and washers as shown. See Dia #22.

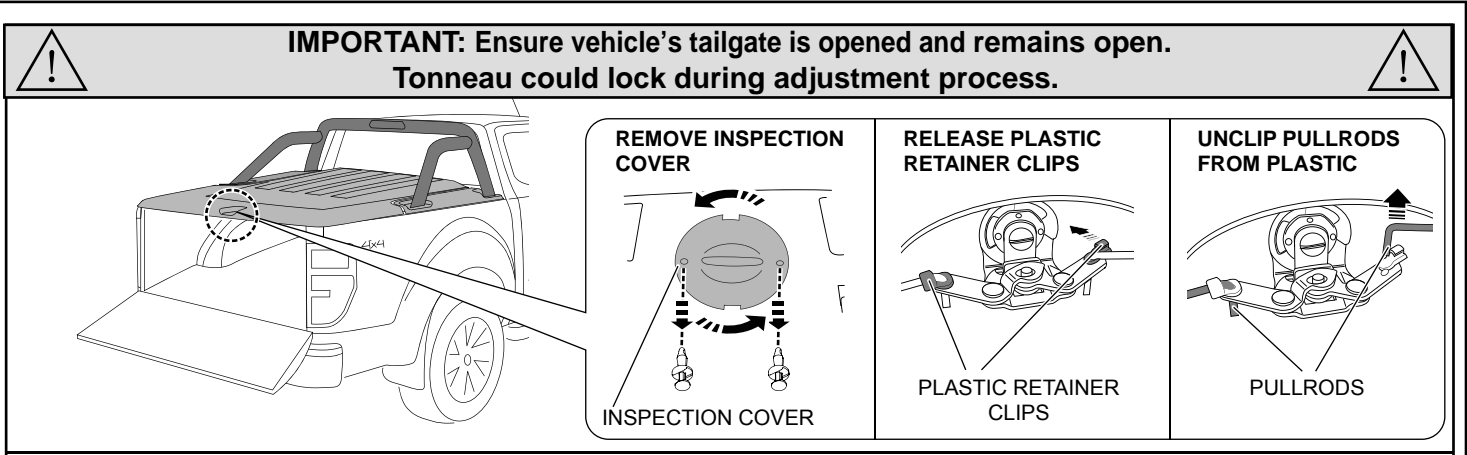

**Diagram #23**

23. Open Tonneau Cover and remove inspection cover by removing scrivenets and rotating cover anti-clockwise. Release plastic retainer clips and unclip pullrods as shown. **See Dia #23.**

**IMPORTANT: TAILGATE MUST BE OPEN, TONNEAU COULD LOCK DURING ADJUSTMENT PROCESS.**

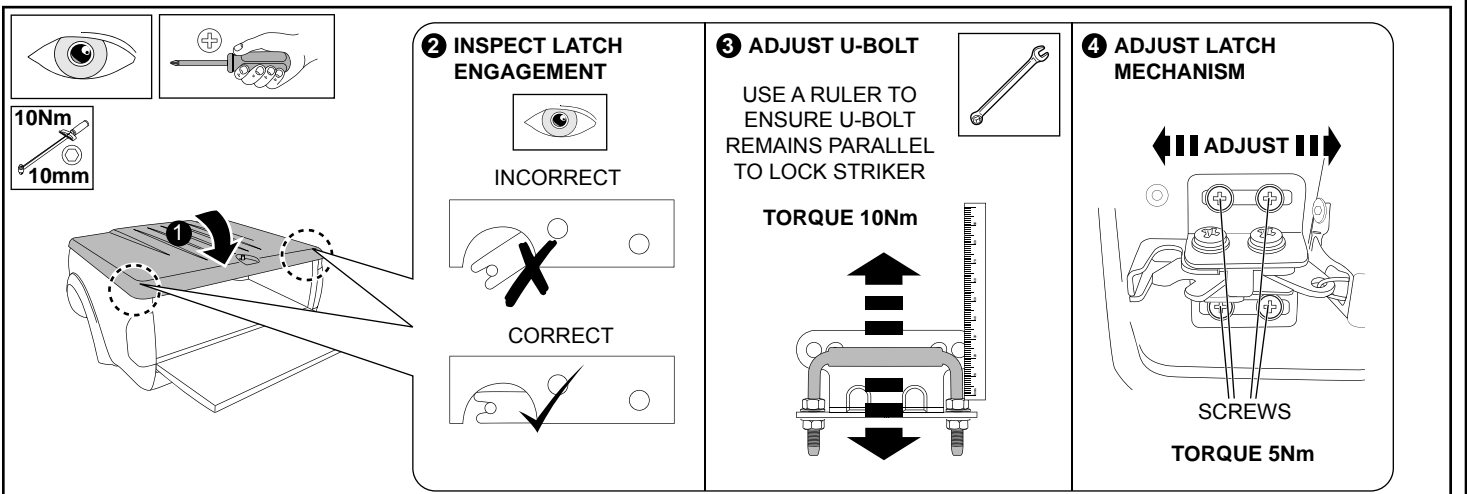
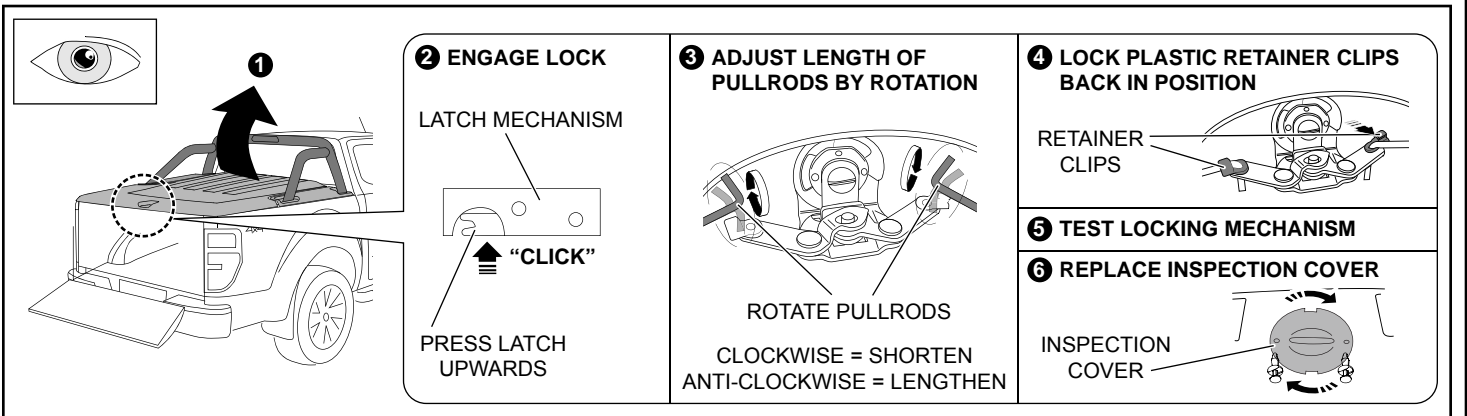

**Diagram #24**

24. Close Tonneau Cover and inspect locking mechanism. Ensure the latch hits the striker bracket centrally. If it **DOES NOT**, adjust the latch accordingly by loosening the screws and moving the latch left or right as shown. Tighten to **torque 5Nm**.

Adjust the height of the lock striker bracket by moving it up or down as shown. Tighten nuts to **torque 9Nm**. **See Dia #24.**

**Note: Tonneau Cover has 2 stage locks as a safety feature. Ensure Tonneau engages with second stage of the latch.**



**Diagram #25**

25. Open the Tonneau Cover and engage the lock by pressing upwards on the latch. Adjust pullrods so that they clip back into the retainer clips correctly. Do this by rotating them clockwise to shorten them or anti-clockwise to lengthen them (via internal turn buckle). Clip pullrods and retainer clips back into position. Test lock by pressing the button on top of Tonneau Cover. If latch mechanism **DOES NOT** release, return to **Step 3** and shorten the pullrods. If it **DOES** release, replace inspection cover. **See Dia #25.**

**IMPORTANT: Ensure that the Tonneau Cover locking mechanism is functioning correctly before closing tailgate.**



# REMOVAL OF TONNEAU COVER

TWO PEOPLE ARE REQUIRED TO CARRY OUT THE REMOVAL OF THE TONNEAU COVER.

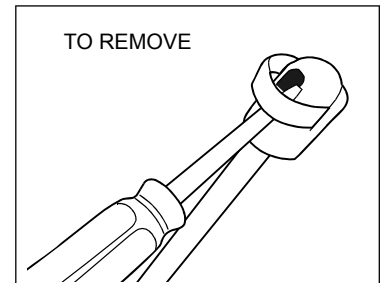
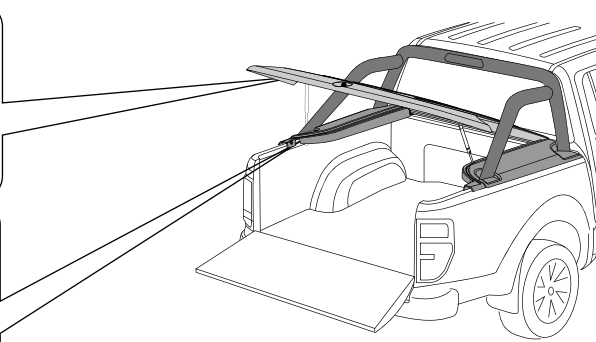
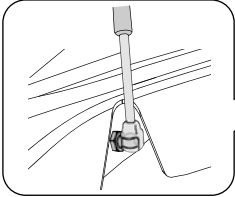
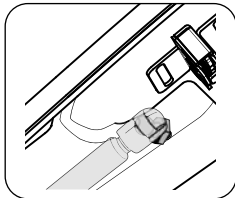
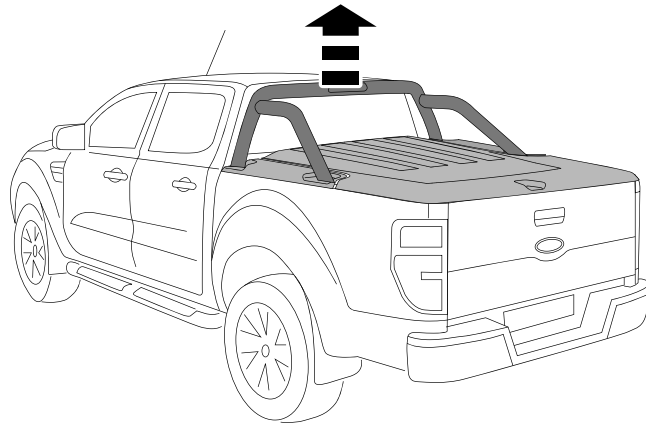

Diagram #:1

1. Detach gas struts by inserting a small screw driver and adjusting the spring clip on the strut. **See Dia #1.**  
**NOTE: Do Not remove the spring clip only a small amount of levering is required to detach.**  
**Do Not remove without using a tool, damage can occur and Void Warranty.**

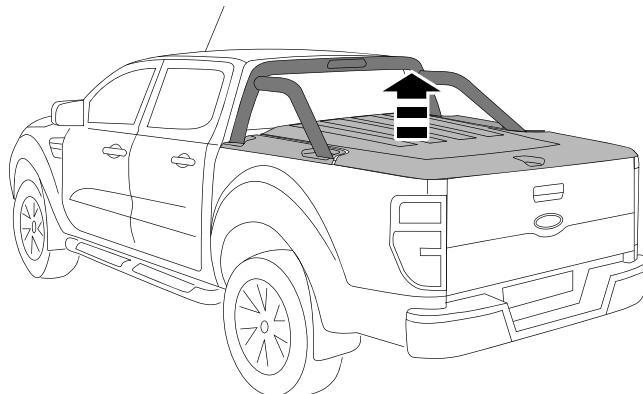
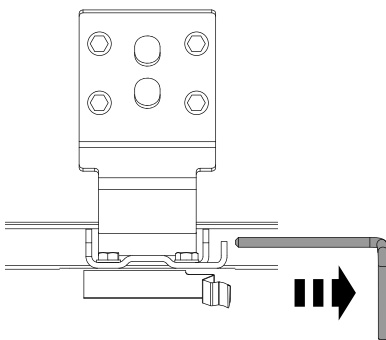

Diagram #:2

2. Remove hinge pins and then remove the Tonneau Cover. **See Dia #2.**